

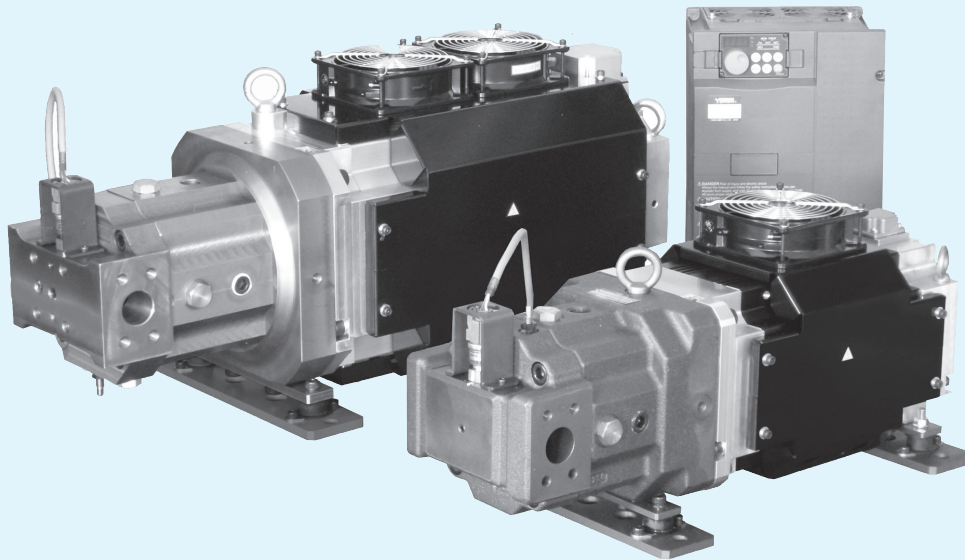

ASE Series AC Servo Motor Driven Pumps

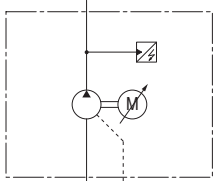
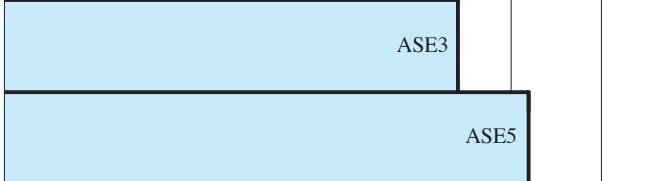
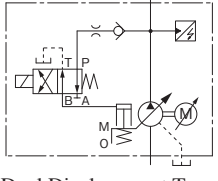

This product is exclusively use for foreign countries outside of Japan.

■ “ASE” Series AC Servo Motor Driven Pumps

Pump Type	Graphic Symbols	Geometric Displacement cm ³ /rev					Maximum Operating Pressure MPa	Page
		0	2	5	10	20		
ASE Series AC Servo Motor Driven Pumps	 Single Displacement Type						17.5	A-234
	 Dual Displacement Type							

■ AMSE Controller A-244

Hydraulic Fluids

Hydraulic Fluids

Use clean petroleum base oils equivalent to ISO VG32 or 46. The recommended viscosity range is from 20 to 400 mm²/s and temperature range is from 0 to 60 °C, both of which have to be satisfied for the use of the above hydraulic oils.

Control of Contamination

Due caution must be paid to maintaining control over contamination of the operating oil which can otherwise lead to breakdowns and shorten the life of the unit. Please maintain the degree of contamination within NAS class 9.

The suction port must be equipped with at least 100 μm (150 mesh) reservoir type filter and the return line must have a line type filter of under 10 μm.

Instructions

Transportation

For transportation, use the lifting rings on the pump. Do not use lifting cables at places other than the lifting rings.

Mounting

When installing the pump, the filling port should be positioned upwards.

Suction Pressure

Permissible suction pressure at the inlet port of the pump is between -16.7 and +50 kPa. For piping to the suction port, use pipes of the nominal diameters shown below. Make sure that the height of the pump suction port is lower than the oil level in the reservoir.

Model	Nominal Dia.
ASE3/ASE5	1 1/2
ASE10	2 1/2
ASE10W	2
ASE15W	3

Hints on Piping

When using steel pipes for the suction or discharge ports, excessive load from the piping to the pump generates excessive noise. Whenever there is fear of excessive load, please use rubber hoses.

Drain Piping

Install drain piping according to the chart and ensure that pressure within the pump housing should be maintained at a nominal pressure of less than 0.1 MPa and surge pressure of less than 0.5 MPa.

The length of piping should be less than 1 m. Instead of joining the drain pipe to other return lines, run it independently. The pipe end should be submerged in oil.

[Recommended Drain Piping Size]

Model	Fitting Size	Inside Dia. of Pipe
ASE3/ASE5	1/2 (Inside Dia. 12 mm or more)	12 mm or more
ASE10/ASE10W/ASE15W	3/4 (Inside Dia. 16 mm or more)	19 mm or more

■ Precautions

This pump does not have a full cut-off function.

Be sure to install an external relief valve for setting the PH pressure (maximum circuit pressure) in the pump discharge line.

■ Starting

Before first starting, fill the pump case with clean operating oil via the filling port. In order to avoid air blockage when first starting, adjust the control valves so that the discharged oil from the pump is returned directly to the reservoir or the actuator moves in a free load.

■ Bleeding Air

It may be necessary to bleed air from the pump case and lines to remove causes of vibration. An air bleed valve (Model Number: ST1004, Page A-259) in the outlet line is recommended.

For air bleeding with an air bleed valve installed, run the pump at a rotational speed that provides a flow rate equal to/higher than the valve's flow rate to reseating.

■ Setting Delivery

At the time of shipment, the unit has been preset to the delivery rate shown below.

[Default Setting of Delivery]

Model Numbers	Single Displacement Type cm ³ /rev	Dual Displacement Type "W" cm ³ /rev	
		Large Displacement	Small Displacement
ASE3	32.3	—	
ASE5	57.7	—	
ASE10	102.7	—	
ASE10W	—	100	58
ASE15W	—	151	100

■ Precautions During Operation

During and for a period after operation, the surface temperature of the AC servo motor and the pump will be hot. Prevent hands and other body parts from coming into contact with them.

[Volume of Pre-fill Oil Required]

Model	Volume cm ³
ASE3/ASE5	600
ASE10	900
ASE10W	2200
ASE15W	3100

● Adjustment of Delivery

There is no flow adjustment screw for the single displacement type. Tuning the large displacement side flow adjustment screw for the dual displacement type clockwise decreases the delivery. Turning the small displacement side flow adjustment screw for the dual displacement type clockwise increases the delivery.

[Volume adjusted by each full turn of the flow adjustment screw]

Model Numbers	Dual Displacement Type "W" cm ³ /rev	
	Large Displacement	Small Displacement
ASE10W	5.3	7.4
ASE15W	7.2	9.6

★ For the relationship between the flow adjustment screw position and flow adjustment, see pages A-237.

Providing flexible flow/pressure control !

ASE Series AC Servo Motor Driven Pumps

The ASE series pumps inherit the basic concept of the shaft speed control from the ASR series pumps and offer high cost performance. The pumps of this series offer easy shaft speed control for systems that do not require as much precision, response, or repeatability as the ASR series pumps offer.

System Configuration

A feedback loop is formed by the AMSE controller that computes deviations between control signals from the machine side (speed and pressure commands) and sensor signals to drive the AC servo motor accordingly. Control parameters can be set digitally by using dedicated software.

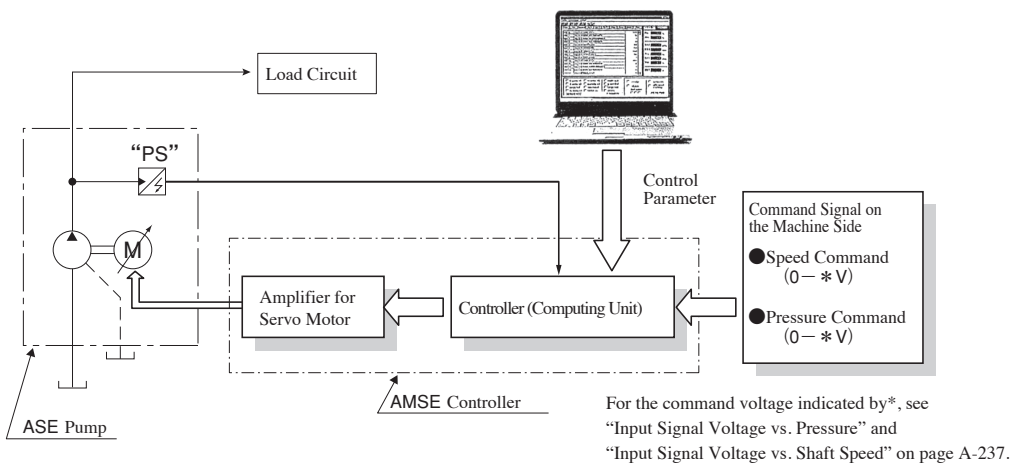
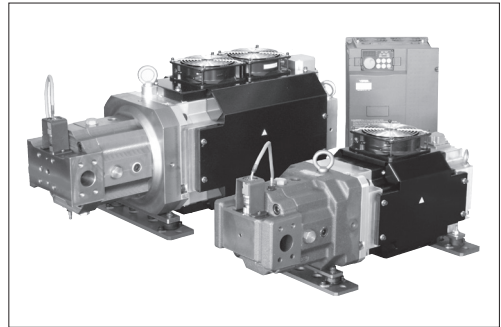

Graphic Symbols

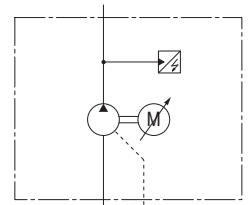

Single Displacement Type ASE *

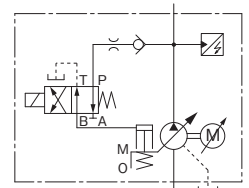

Dual Displacement Type ASE * W

- **Energy saving with low heat generation**
These pumps run at a rotational speed suitable for mechanical requirements, eliminating unnecessary power loss. They minimize heat generation in the fluid and allow the use of a significantly smaller reservoir.
- **Low noise**
Noise reduction insulation included as standard.
- **Less wiring / high reliability**
Uses sensor-less rotational speed control.
- **Digital AMSE controller that saves space and wiring**
The integration of the amplifier for the servo motor and the controller saves space and wiring. The parameters can be digitally adjusted in an easy and repeatable way.
- **Dual displacement type for a wider operation range**
The dual displacement type has a solenoid operated directional valve to switch between large and small swash plate angles. A single pump unit of the dual displacement type can operate both with low pressure/large flow and with high pressure/small flow. Thus, in comparison to the single displacement type with the same motor capacity, the dual displacement type covers a significantly wider range of operating pressures and flow rates.
- **Large flow**
The AMSE controller has a combination function that supports operation with large flow up to 4800 L/min (ASE15W × 16 units).

Specifications

Descriptions		Model Numbers					
		ASE3	ASE5	ASE10	ASE10W	ASE15W	
Power Capacity		AA	BZ	CE	BZ	CE	
Pump	Flow Control	Max. Flow	80.8 L/min	132.7 L/min	205.4 L/min	200 L/min	302 L/min
		Min. Adj. Flow	2 %				
		Hysteresis	1 % or less				
		Repeatability	1 % or less				
		Input Signal Voltage	64.6 L/min/5V	115.4 L/min/5V	205.4 L/min/5V	200 L/min/5V	302 L/min/5V
	Max. Permissible Input Signal Voltage*1	80.8 L/min/6.25V	132.7 L/min/5.75V				
	Pres. Control	Max. Operating Pres.	17.5 MPa			17.5 MPa (21 MPa)*2	
		Min. Adj. Pres.	0.1 MPa				
		Hysteresis	1 % or less				
		Repeatability	1 % or less				
Input Signal Voltage		17.5 MPa/5V			17.5 MPa/5V		
Max. Permissible Input Signal Voltage*1				21 MPa/6V			
AC Servo Motor Specifications	Rated Output	11 kW	20 kW	35 kW	20 kW	35 kW	
	Insulation Class	Class F					
	Cooling System	Totally-enclosed Fan-cooling					
	Cooling Fan Power Consumption	20W(50Hz)/18W(60Hz)	40W(50Hz)/36W(60Hz)	60W(50Hz)/54W(60Hz)	40W(50Hz)/36W(60Hz)	60W(50Hz)/54W(60Hz)	
	Environmental Condition	0 - +40 °C (No Freezing)					
Ambient Humidity	80 %RH or less (No Condensation)						
Mass	200 V AC Type	75 kg	123 kg	185 kg	180 kg	—	
	400 V AC Type	79 kg	116 kg	180 kg	173 kg	231.5 kg	
Applicable Controller Model Number		AMSE-*AE**-10	AMSE-*BB**-11	AMSE-*DE**-10	AMSE-*BB**-11	AMSE-*DE**-10	

*1. By adjusting the controller, the maximum flow rate/5 V (80.8 L/min/5 V) and the maximum operating pressure/5 V (21 MPa/5 V) can be set.

*2. Depending on the value of geometric displacement.

Model Number Designation

The model numbers below indicate packages each containing an AC servo motor driven pump, AMSE controller, and Regeneration Resistors.

ASE10W	-4	BZ	-G	W	S	A100	N	-B	00	-20
Series Number *1	Power Supply Voltage	Power Capacity *2	Max. Operating Pres.	Max. Flow	Port Direction	Coil Type for Solenoid Operated Directional Valve	Electrical Conduit Connection for Solenoid Operated Directional Valve	Function Selection	Parameter Number	Design Number
ASE3	None: 200 V AC	AA	G:17.5 MPa (21 MPa) *3	80: 80.8 L/min	S:Horizontal B:Vertical	—	—	B: Combination (Single Use Allowed)*4	00: Standard	40
ASE5		BZ		130: 132.7 L/min						40
ASE10		CE		200: 205.4 L/min						30
ASE10W	4: 400 V AC	BZ	G:17.5 MPa (21 MPa) *3	W:User Setting "100/58*5" Large Flow (Sol OFF) 100 cm ³ /rev (200 L/min) Small Flow (Sol ON)*6 58 cm ³ /rev (133 L/min)	S:Horizontal B:Vertical	AC A100:100 V AC A120:120 V AC A200:200 V AC A240:240 V AC	None: Terminal Box	B: Combination (Single Use Allowed)*4	00: Standard	20
ASE15W	4:400 V	CE		W:User Setting "151/100*5" Large Flow (Sol OFF) 151 cm ³ /rev (302 L/min) Small Flow (Sol ON) 100 cm ³ /rev (200 L/min)		DC None:24 V DC D12:12 V DC D48:48 V DC D100:100 V DC D110:110 V DC D200:200 V DC D220:220 V DC				N: DIN Plug-in Connector
						AC(AC⇔DC) R100:100 V AC R110:110 V AC R200:200 V AC R220:220 V AC				

*1. To order an AC servo motor driven pump separately for spare use, prefix "N-" to the model number and omit the Function Selection and Parameter Number.

Example) N-ASE10W-4BZ-GWSA100N-20

*2. For the relationship between the power capacity and the pressure/flow in terms of specification limits, see charts on page A-238.

*3. For the models ASE10W/ASE15W, it depends on the value of geometric displacement.

*4. For combination operation, consult us separately regarding the types of hydraulic circuits, components, and electric cables.

*5. Ex. The factory-adjusted value can be set to 70/40.[70: 70 cm³/rev (Large Flow) and 40: 40cm³/rev. (Small Flow)]

*6. The maximum revolutions can reach to 2300 r/min if the pump capacity is set to less than 60 cm³/rev.

■ Solenoid Ratings

See Solenoid Ratings (page A-51).

■ Pipe Flange Kit

No pipe flange kit is included with the pump. The pipe flange kits below are available if required. For the details of the pipe flange kits, see pages A-258 and A-259.

Pump Model Numbers	Name of Port	Pipe Flange Kit Numbers		
		Threaded Connection	Socket Welding	Butt Welding
ASE3 ASE5	Suction	F5-12-A-10	F5-12-B-10	F5-12-C-10
	Discharge	F5-10-A-10	—	F5-10-C-10
ASE10	Suction	F5-20-A-10	F5-20-B-10	F5-20-C-10
	Discharge	F5-10-A-10	—	F5-10-C-10
ASE10W	Suction	F5-16-A-10	F5-16-B-10	F5-16-C-10
	Discharge	F5-10-A-10	—	F5-10-C-10
ASE15W	Suction	F5-24-A-10	F5-24-B-10	F5-24-C-10
	Discharge	F5-12-A-10	—	F5-12-C-10

Characteristics of Single Displacement Type

Input Signal Voltage vs. Pressure

● ASE3/ASE5/ASE10

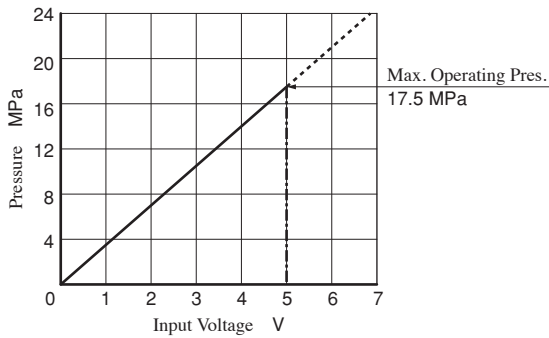

● ASE10W/ASE15W

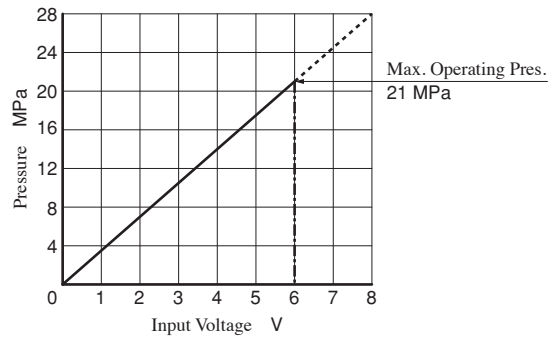

★ Do not input a voltage higher than the level corresponding to the maximum operating pressure.

Input Signal Voltage vs. Shaft Speed

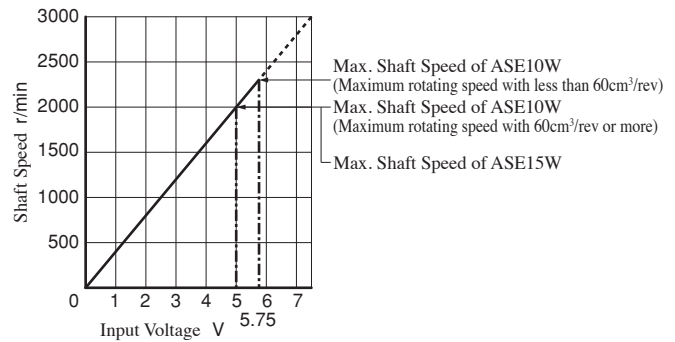
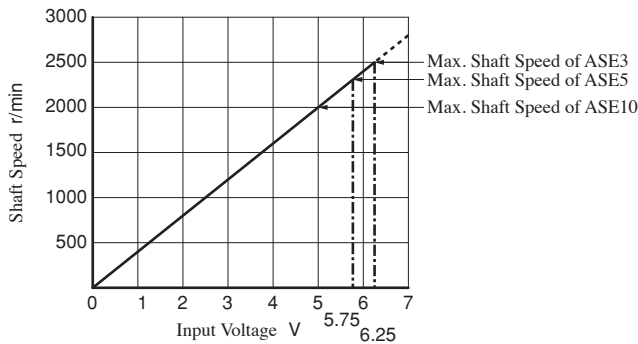

★ Do not input a voltage higher than the level corresponding to the maximum shaft speed.

Flow Adjustment Screw Projection and Geometric Displacement

● ASE10W

Large displacement (SOL:OFF)

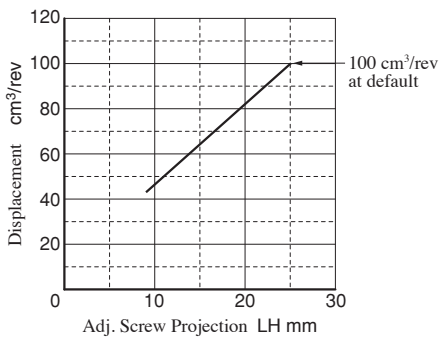

Small displacement (SOL:ON)

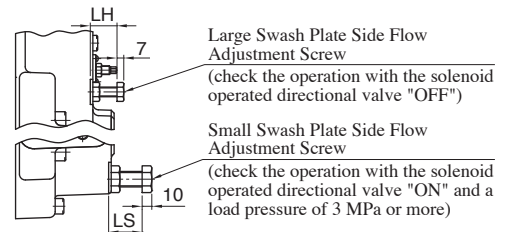
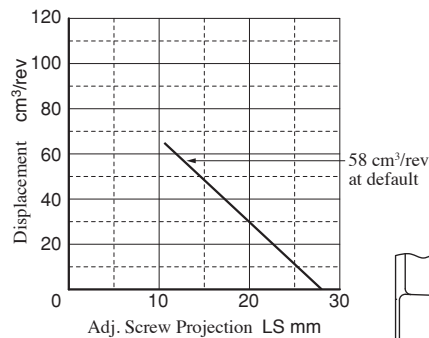

● ASE15W

Large displacement (SOL:OFF)

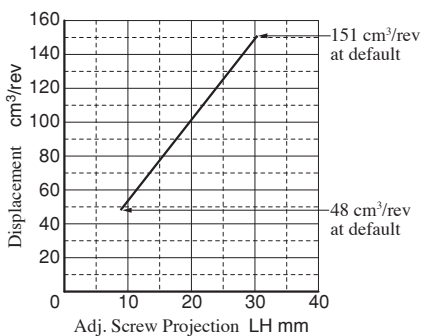

Small displacement (SOL:ON)

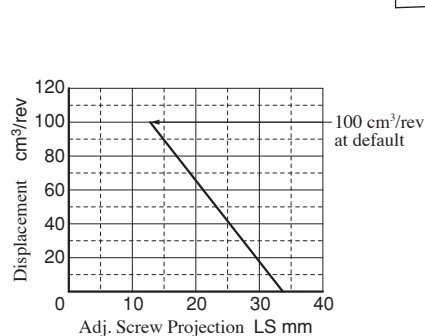

Pressure vs. Discharge Flow (Reference)

----- Max Continuous Operation Time: 60 sec.

● ASE3- *AA-G80* -

Pressure enabling continuous operation: 11 MPa or less

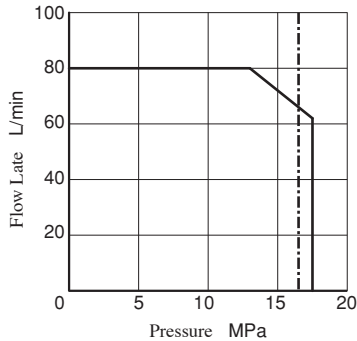

● ASE5- *BZ-G130* -

Pressure enabling continuous operation: 11 MPa or less

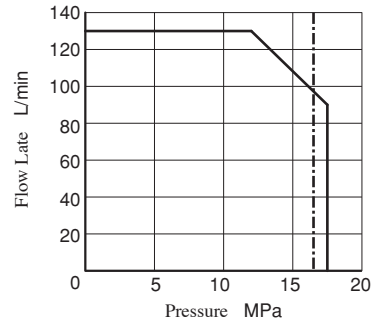

● ASE10-CE-G200* -

Pressure enabling continuous operation: 10 MPa or less

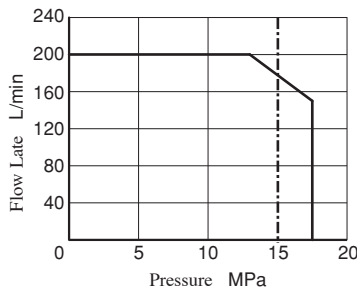

● ASE10-4CE-G200* -

Pressure enabling continuous operation: 11 MPa or less

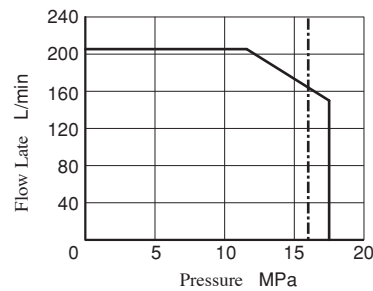

● ASE10W- *BZ-G* * * * -

Pressure vs. delivery characteristics with 100cm³/rev at the large swash plate side and 58cm³/rev at the small swash plate side
 Pressure enabling continuous operation is 6 MPa for the large swash plate side and 11 MPa for the small swash plate side.

100cm³/rev at the large swash plate side

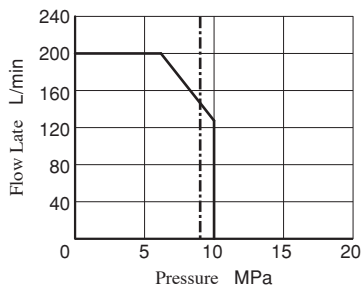

58cm³/rev at the small swash plate side

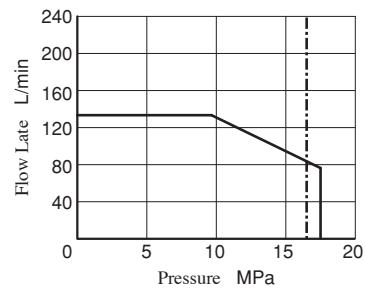

● ASE15W-4CE-G* * * * -

Pressure vs. delivery characteristics with 151cm³/rev at the large swash plate side and 100cm³/rev at the small swash plate side
 Pressure enabling continuous operation is 7 MPa for the large swash plate side and 11 MPa for the small swash plate side.

151cm³/rev at the large swash plate side

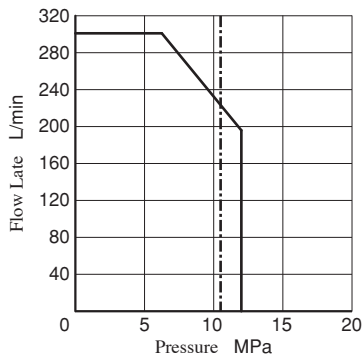

100cm³/rev at the small swash plate side

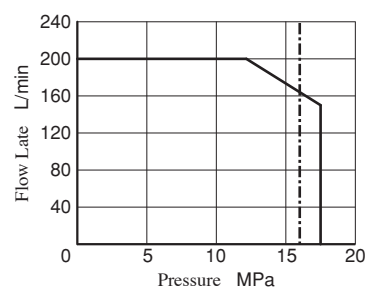

ASE3-AA- ** S- (Horizontal Port Type)

Single Displacement Type

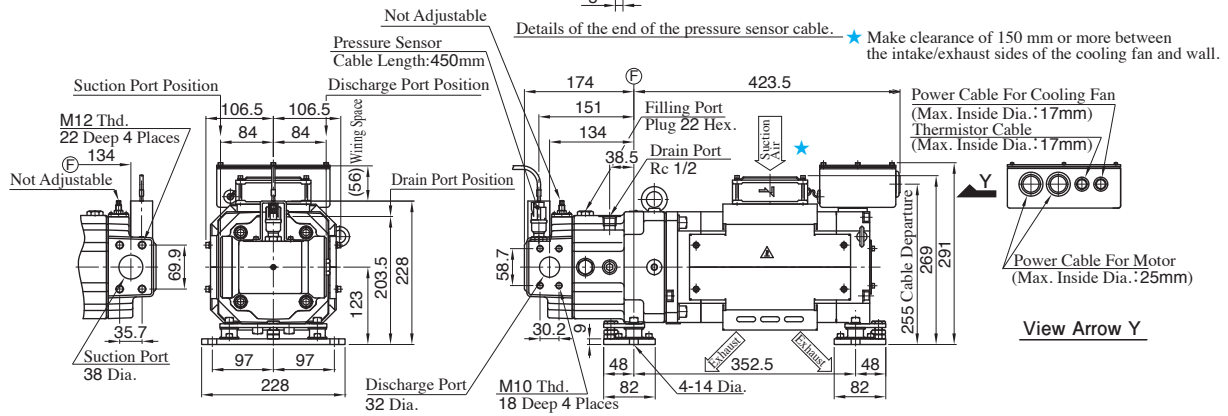

ASE3-AA- ** B- (Vertical Port Type)

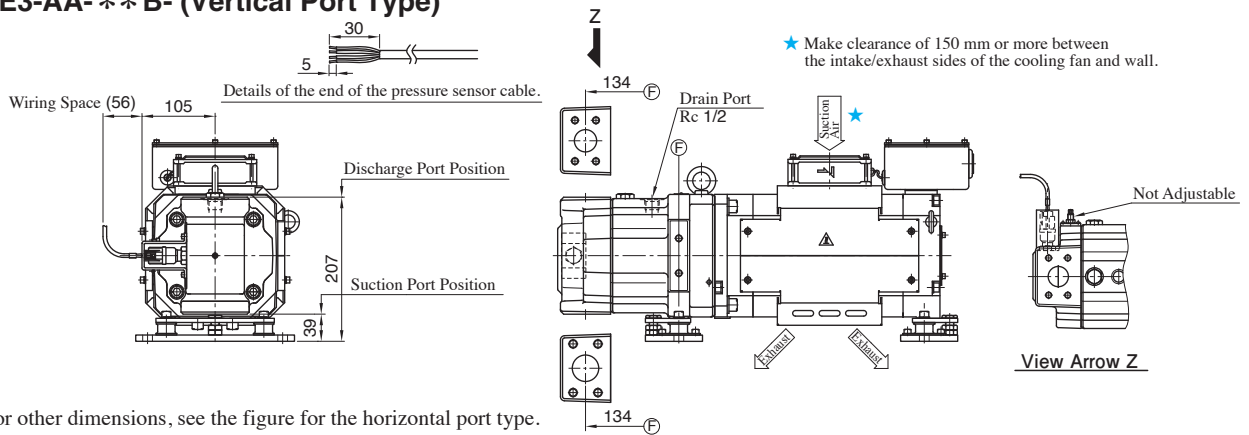

● For other dimensions, see the figure for the horizontal port type.

ASE3-4AA- ** S- (Horizontal Port Type)

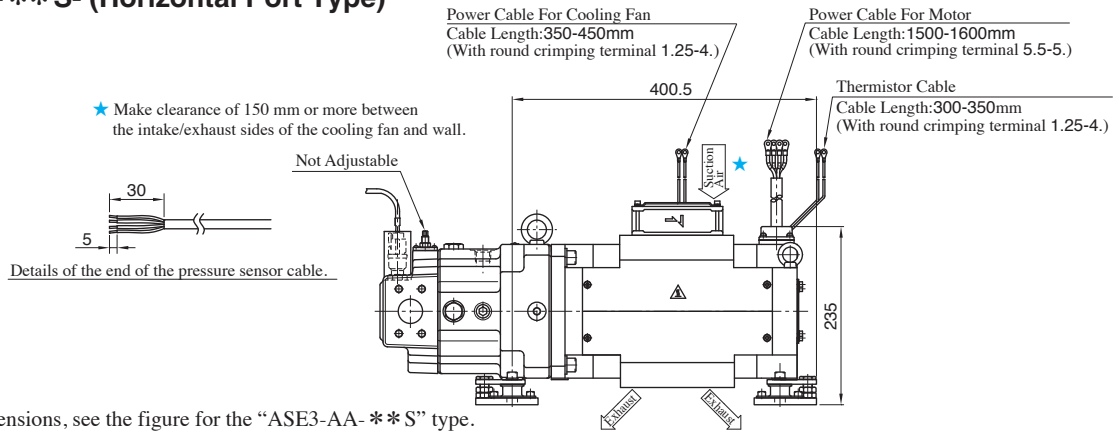

● For other dimensions, see the figure for the "ASE3-AA- ** S" type.

ASE3-4AA- ** B- (Vertical Port Type)

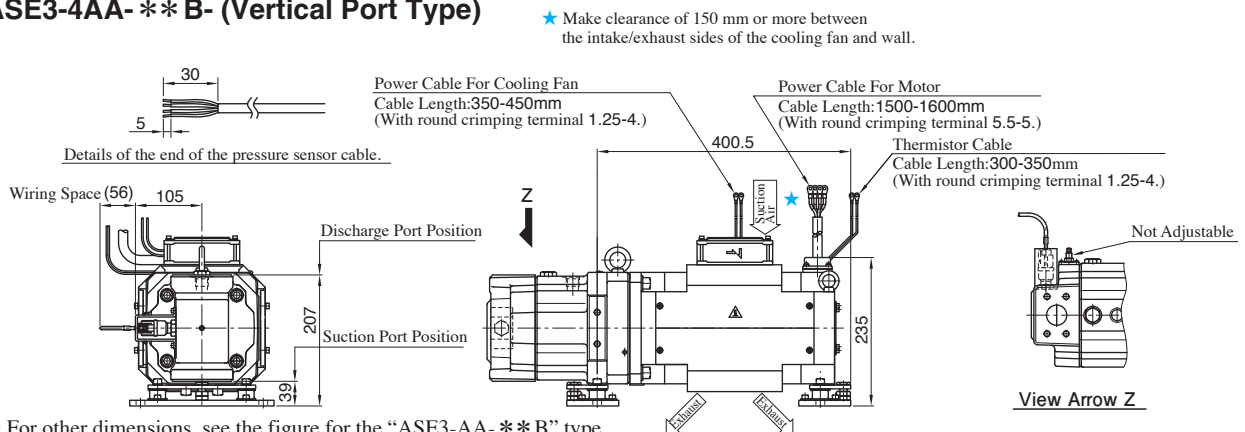

● For other dimensions, see the figure for the "ASE3-AA- ** B" type.

ASE5-BZ- ** S- (Horizontal Port Type)

Single Displacement Type

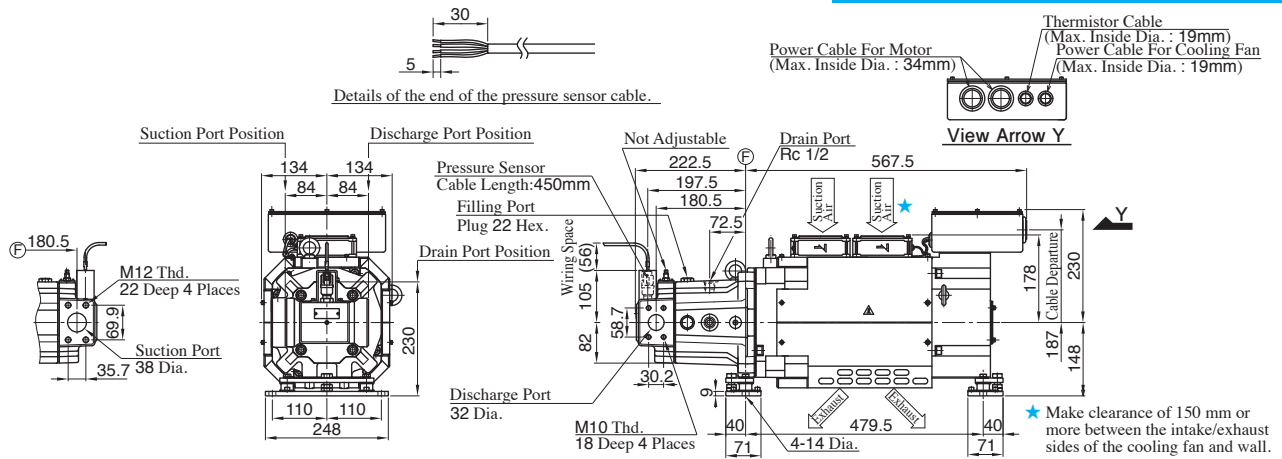

ASE5-BZ- ** B- (Vertical Port Type)

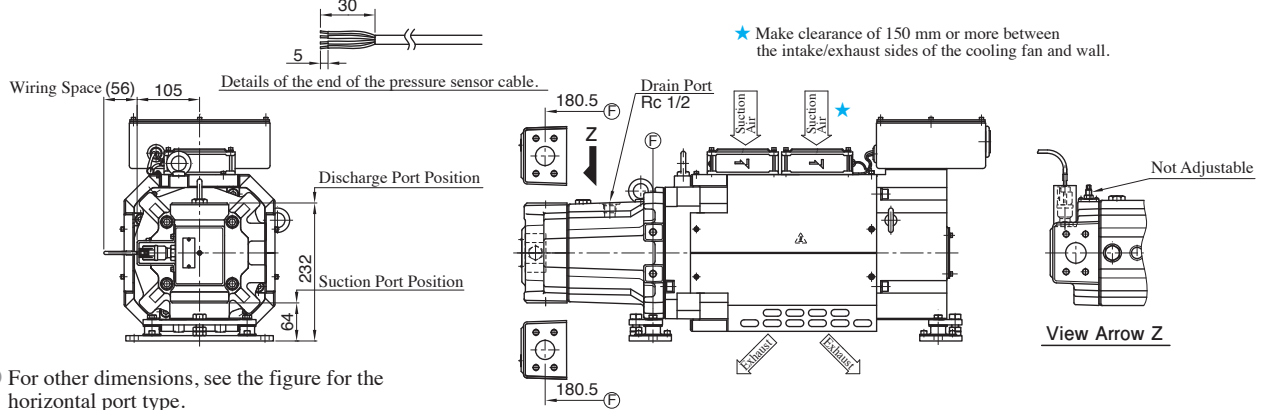

● For other dimensions, see the figure for the horizontal port type.

ASE5-4BZ- ** S- (Horizontal Port Type)

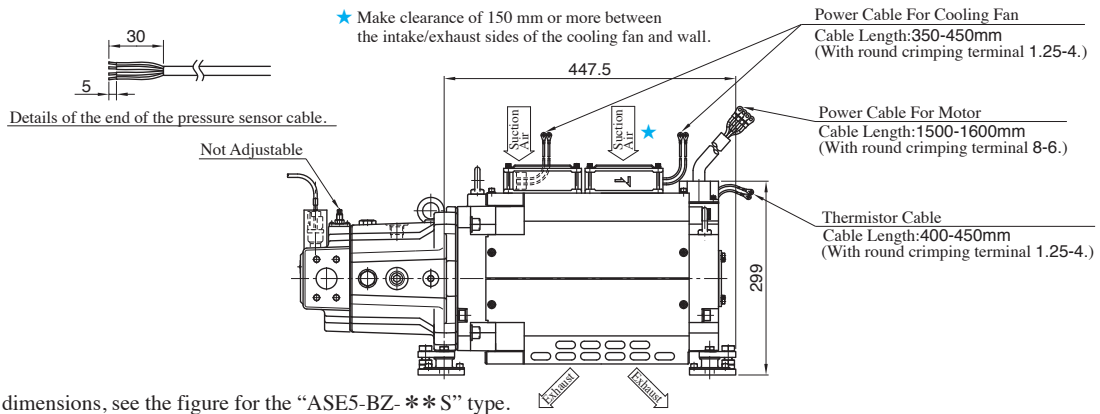

● For other dimensions, see the figure for the "ASE5-BZ- ** S" type.

ASE5-4BZ- ** B (Vertical Port Type)

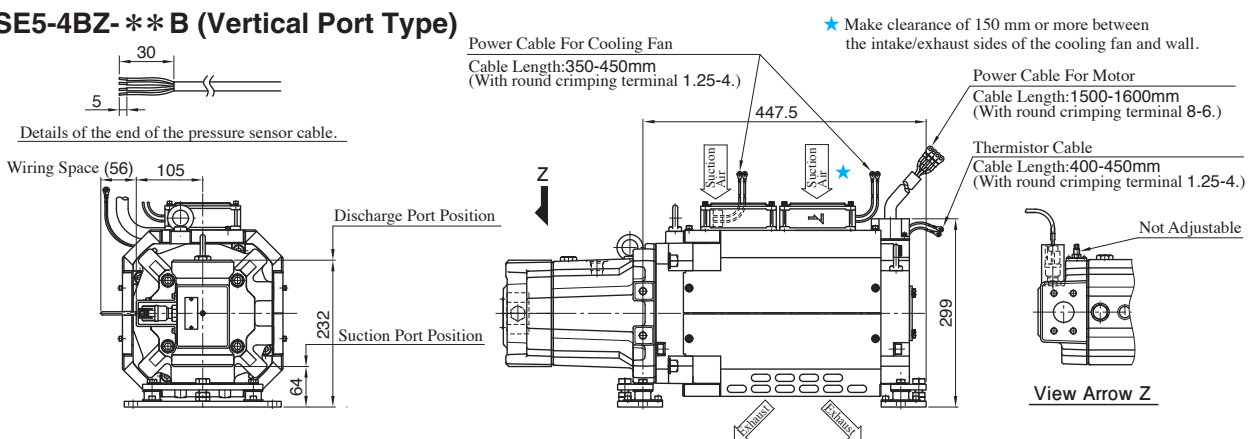

● For other dimensions, see the figure for the "ASE5-BZ- ** B" type.

ASE10-CE- ** S- (Horizontal Port Type)

Single Displacement Type

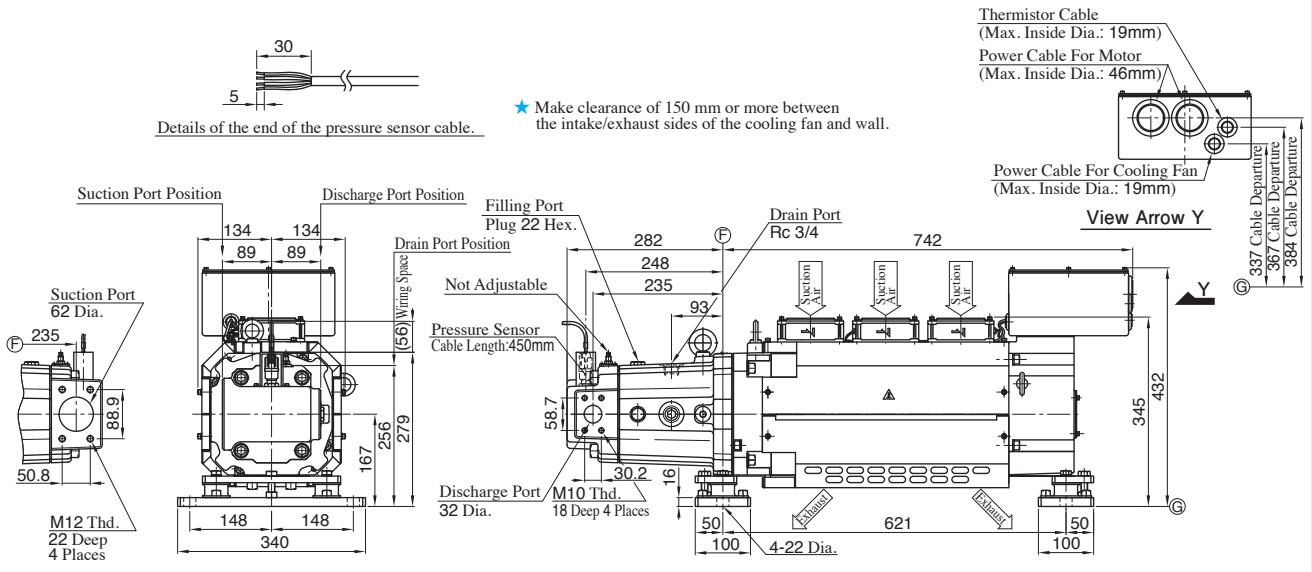

ASE10-CE- ** B- (Vertical Port Type)

★ Make clearance of 150 mm or more between the intake/exhaust sides of the cooling fan and wall.

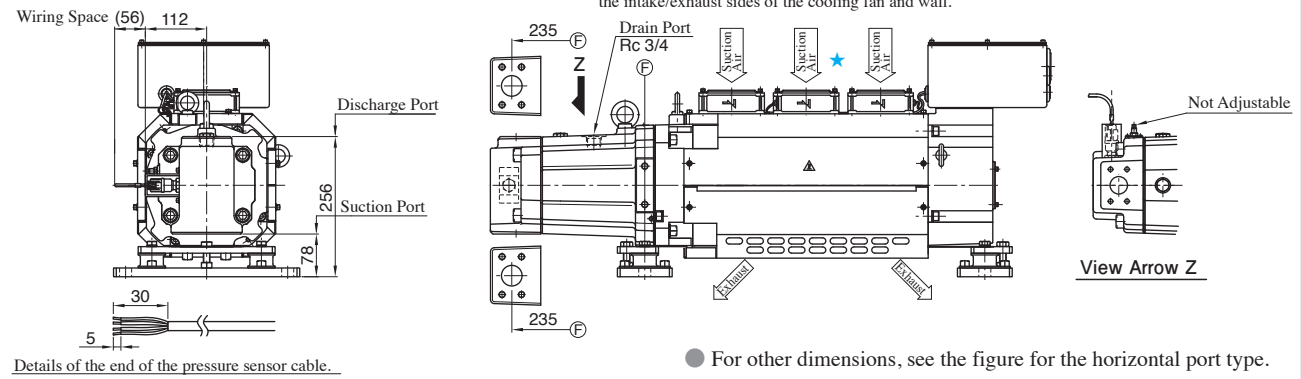

ASE10-4CE- ** S- (Horizontal Port Type)

★ Make clearance of 150 mm or more between the intake/exhaust sides of the cooling fan and wall.

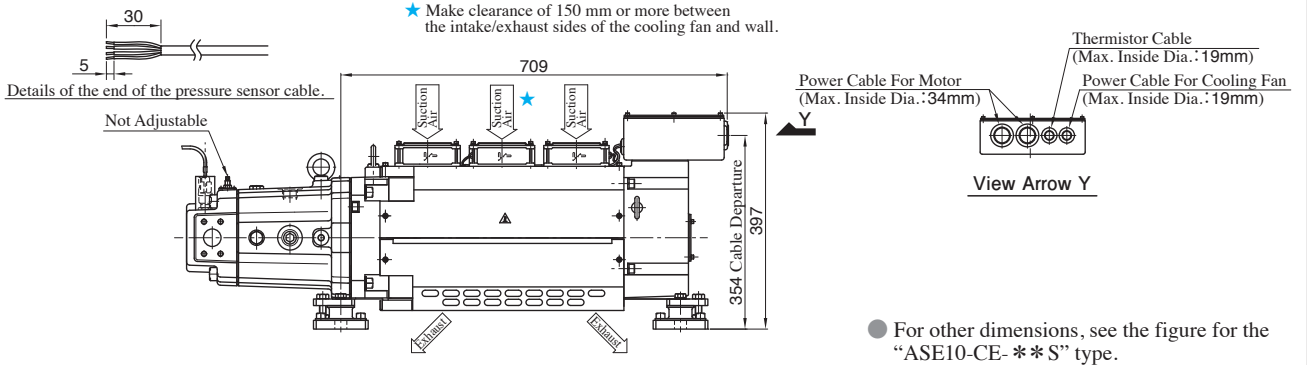

ASE10-4CE- ** B (Vertical Port Type)

★ Make clearance of 150 mm or more between the intake/exhaust sides of the cooling fan and wall.

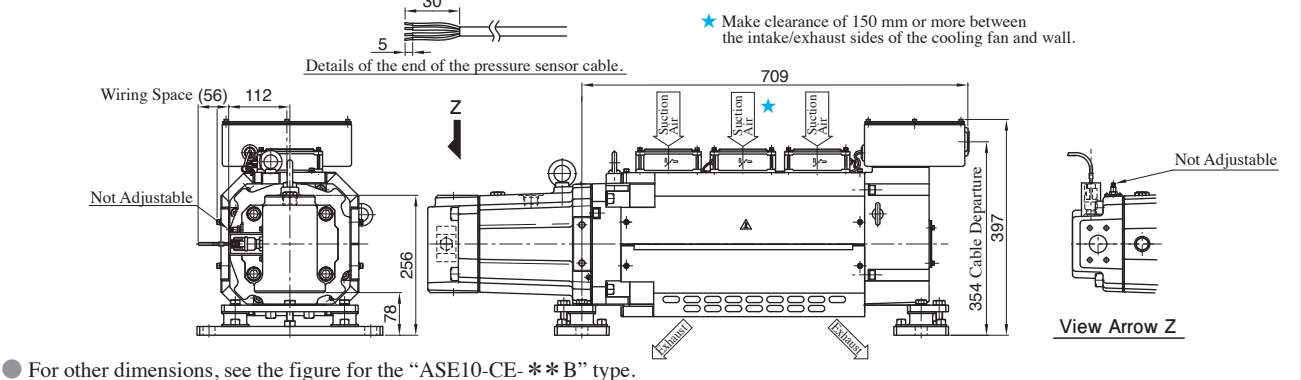

ASE10W-BZ-G * S * * - (Horizontal Port Type)

Dual Displacement Type

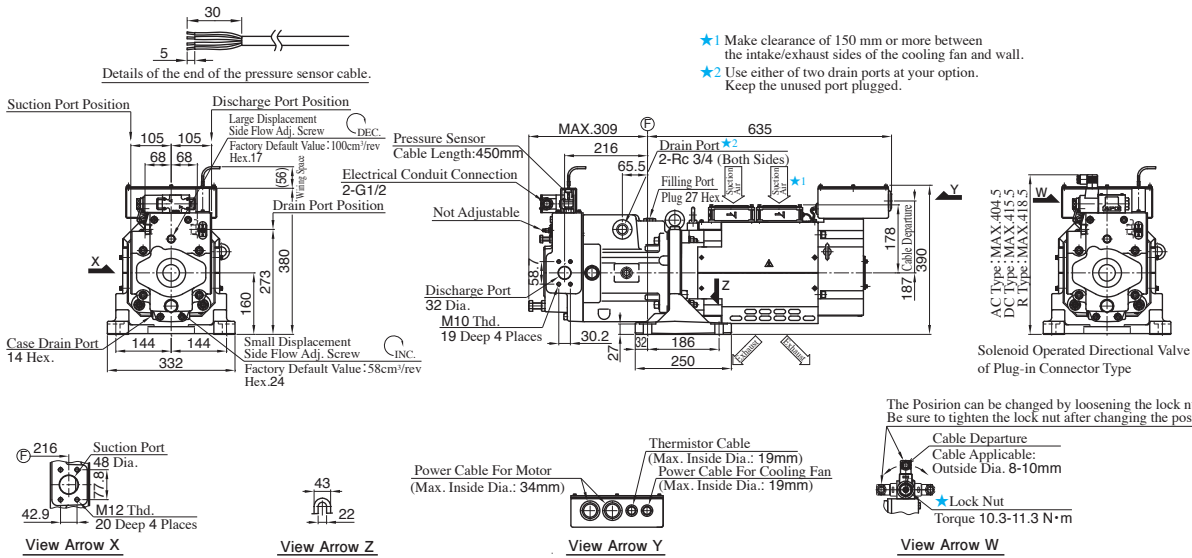

ASE10W-BZ-G * B * * - (Vertical Port Type)

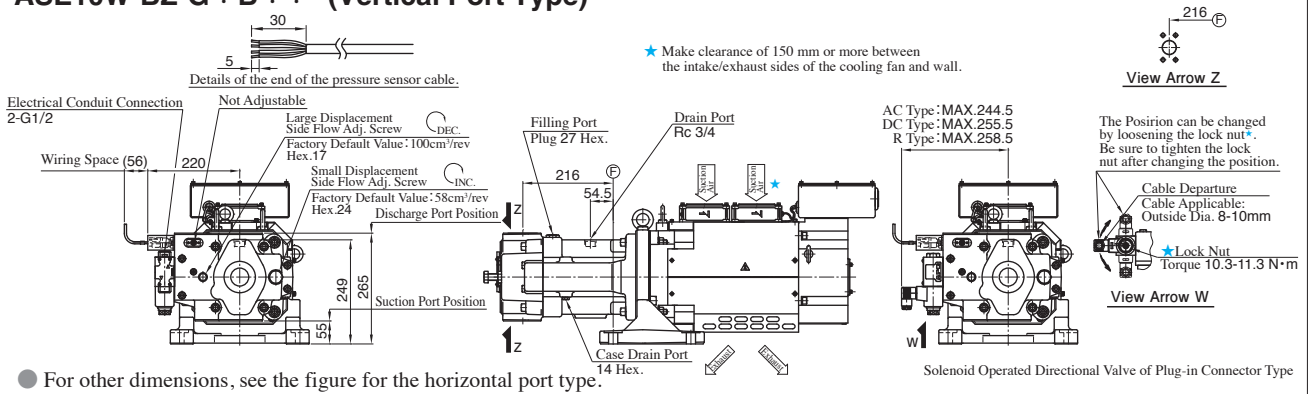

ASE10W-4BZ-G * S * * - (Horizontal Port Type)

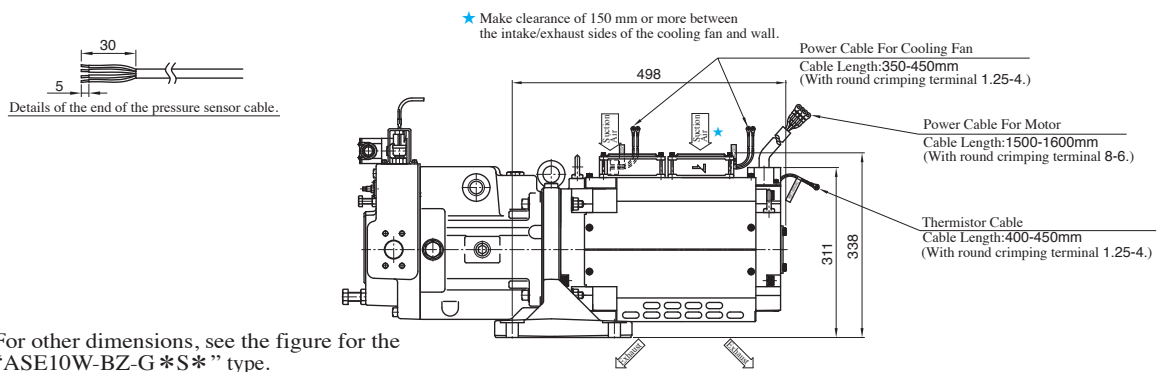

ASE10W-4BZ-G * B * * - (Vertical Port Type)

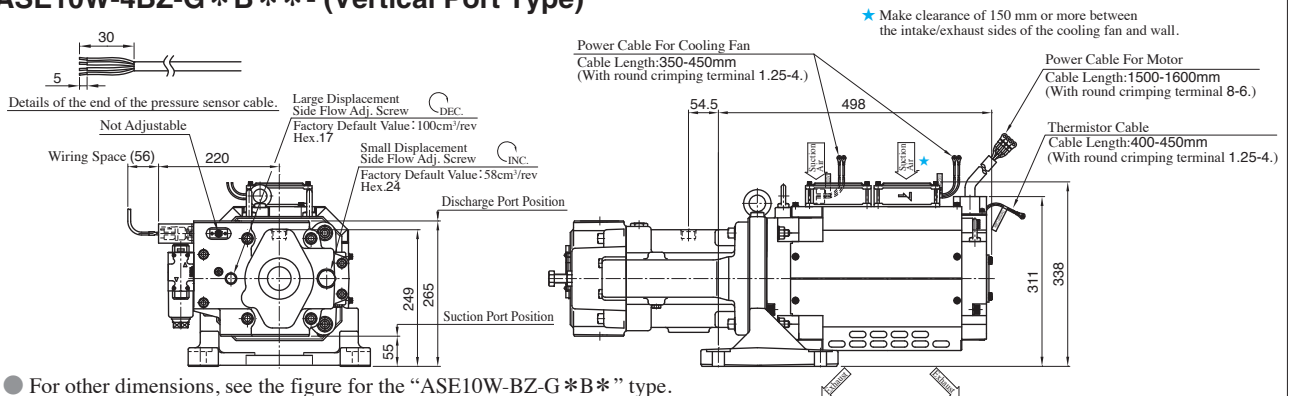

ASE15W-4CE-G * S * * - (Horizontal Port Type)

Dual Displacement Type

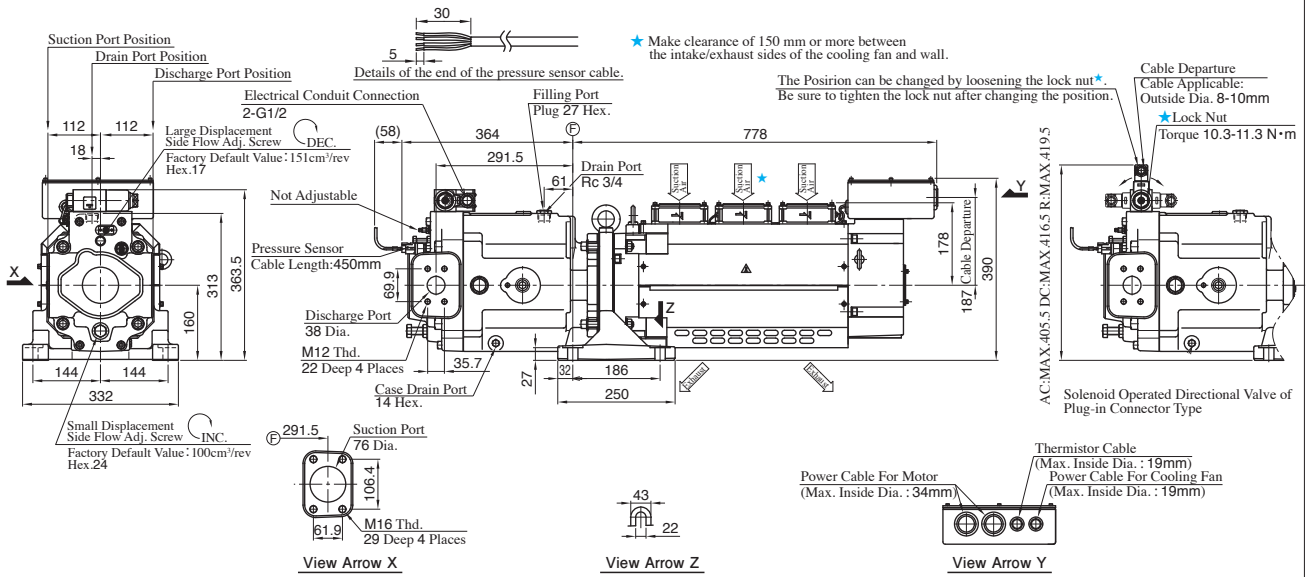

ASE15W-4CE-G * B * * - (Vertical Port Type)

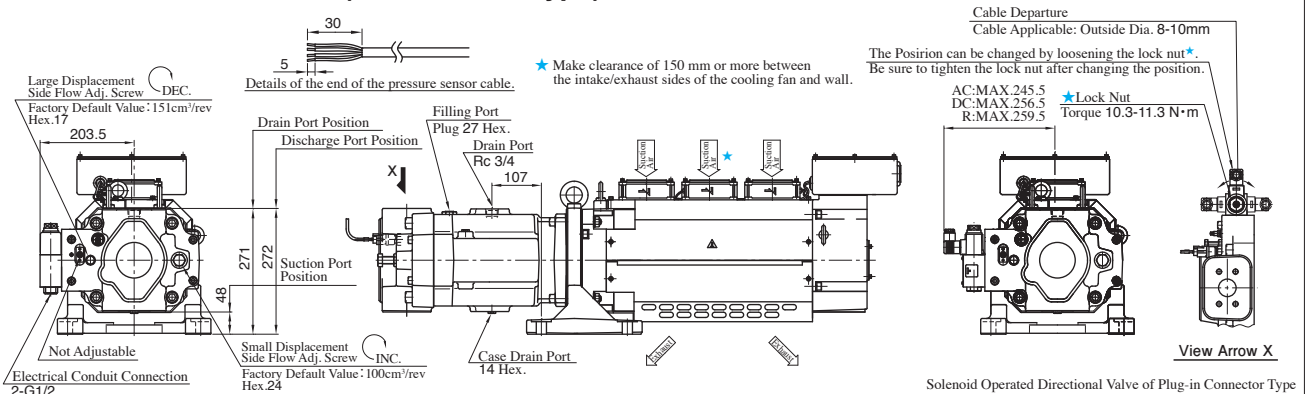

● For other dimensions, see the figure for the horizontal port type.

AMSE Controller

The AMSE controller is used to drive ASE series AC servo motor driven pumps. With an optimal design for the ASE pumps, the controller can maximize the pump performance. The AMSE controller is included with the ASE series pumps.



Specifications

Model Numbers	AMSE- *AE- * *-10		AMSE- *BB- * *-11		AMSE- *DE- * *-10	
	2AE	4AE	2BB	4BB	2DE	4DE
Command Signal Input Voltage	0 - +5 V DC/RATED (MAX. 0 - +10 V)					
Control Method	Vector Control Sensorless					
Monitor Output Voltage	1ch, 0 - +10 V DC					
Digital Monitor	1ch,(FM or Open Collector)					
Sequence Input Signal	12ch.Photo Coupler (Input Resistance : 4.7kΩ) Logic switching is possible by the internal jumper connector (Initial : Sink)					
Voltage At Opening	21-27 V DC					
	Short-Circuited					
Sequence Output Signal	Reray					
	Open Collector					
Voltage/Frequency	200-220 V AC : 50Hz 200-240 V AC : 60Hz 3-Phase	380-480 V AC : 50/60Hz 3-Phase	200-220 V AC : 50Hz 200-240 V AC : 60Hz 3-Phase	380-480 V AC : 50/60Hz 3-Phase	200-220 V AC : 50Hz 200-240 V AC : 60Hz 3-Phase	380-480 V AC : 50/60Hz 3-Phase
Permissible Voltage Fluctuation	170-242 V AC : 50Hz 170-264 V AC : 60Hz 3-Phase	323-528 V AC : 50/60Hz 3-Phase	170-242 V AC : 50Hz 170-264 V AC : 60Hz 3-Phase	323-528 V AC : 50/60Hz 3-Phase	170-242 V AC : 50Hz 170-264 V AC : 60Hz 3-Phase	323-528 V AC : 50/60Hz 3-Phase
Permissible Frequency Fluctuation	Within ±5 %					
Power Supply Capacity*1	28 kVA	27 kVA	41 kVA		80 kVA	
Regeneration Resister (Dynamic Brake)	External Option					
Protection, Cooling	Enclosed Type (IP20), Forced Air Cooling				Open Type (IP00), Forced Air Cooling	
Environmental condition	Ambient Temperature					
	Ambient Humidity					
	Atmosphere					
	Altitude					
	Vibration					
Protective/Warning Functions	Overcurrent · Overvoltage · Inverter Protection Thermal · Motor Protection Thermal · Heatsink Overheat · Instantaneous Power Failure Occurrence · Undervoltage · Input Phase Loss · Motor Overload · Output Side Earth Fault Overcurrent · Output Phase Loss · CPU Fault · Option Fault · Parameter Error · Power Supply Short Circuit · Inrush Current Limit Circuit Fault · Communication Fault · Analog Input Fault · Fan Fault · Overcurrent Stall Prevention · Electronic Thermal Relay Function Prealarm · Regenerative Brake Prealarm · Pu Stop · Brake Transistor Alarm · Parameter Write Error · Copyoperation Error · Operation Panel Lock · Parameter Copy Alarm · Pressure Sensor Disconnection · Network Alarm					
Additional Function	-	Resolver Signal Fault · Overspeed · Speed Deviation Large · Z-Phase Tunning Incomplete	-	Resolver Signal Fault · Overspeed · Speed Deviation Large · Z-Phase Tunning Incomplete	-	Resolver Signal Fault · Overspeed · Speed Deviation Large · Z-Phase Tunning Incomplete
Mass	13kg	7.5kg	14kg	13kg	35kg	
Applicable Pump	ASE3- *AA		ASE5- *BZ ASE10W- *BZ		ASE10- *CE ASE15W-4CE	

*1 The power supply capacity varies with the value of the power supply side inverter impedance (including those of the input reactor and cables).

Model Number Designation

AMSE	-2	AE	-B	00	-10
Series Number	Power Supply Voltage	Amplifier Capacity kW	Function Selection	Parameter Number	Design Number
AMSE : AMSE Controller	2 : 200 V AC 4 : 400 V AC	AE : 15.0	B : Combination (Single Operation Allowed)	00 : Standard	10
		BB : 22.0			11
		DE : 45.0			10

AMSE-2AE-B00-10

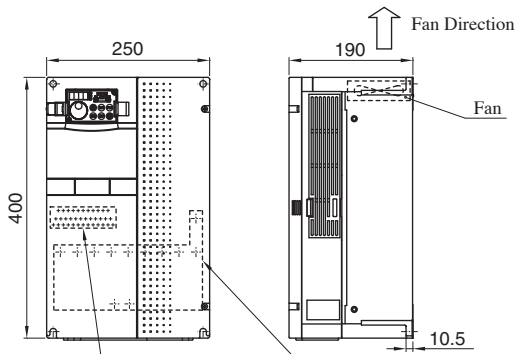

Control Circuit Terminal Assignment (A)



Main Circuit Terminal Assignment (B)

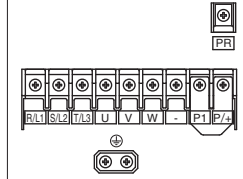

Mountain Hole Dimensions

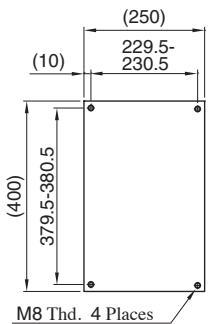

	Main Circuit Terminal R/L1, S/L2, T/L3 U, V, W, P/+, PR, ⊕	Control Circuit Terminal
Terminal Screw	M6	M3.5
Torque [N·m]	4.4	1.2

* Note) Do not connect wiring to the terminals "P1" and "-".

M8 Thd. 4 Places

AMSE-4AE-B00-10

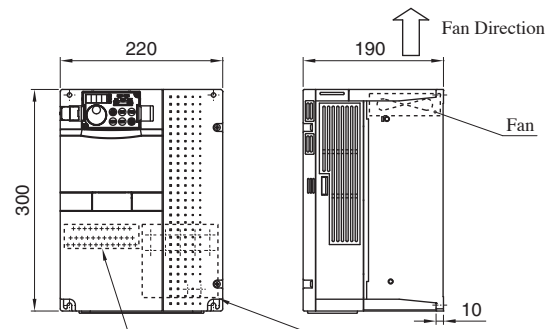

Control Circuit Terminal Assignment (A)

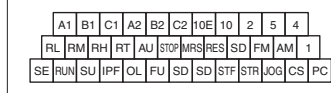

Main Circuit Terminal Assignment (B)

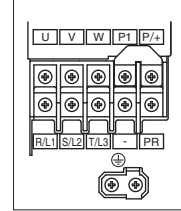

Mountain Hole Dimensions

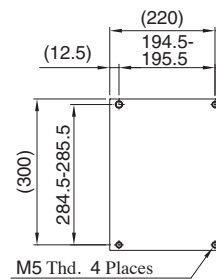

	Main Circuit Terminal U, V, W, P/+, R/L1 S/L2, T/L3, PR, ⊕	Control Circuit Terminal
Terminal Screw	M5	M3.5
Torque [N·m]	2.5	1.2

* Note) Do not connect wiring to the terminals "P1" and "-".

M5 Thd. 4 Places

AMSE-2BB-B00-11

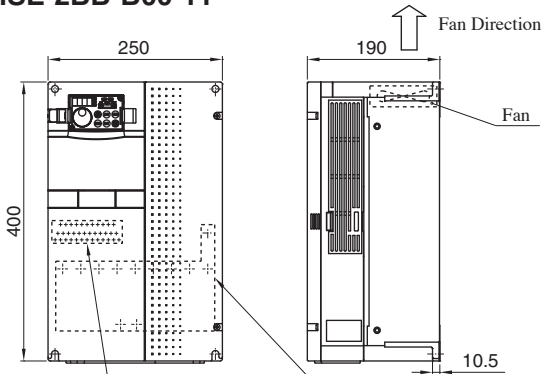

Control Circuit Terminal Assignment (A)

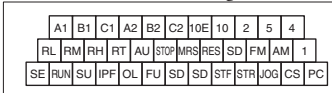

Main Circuit Terminal Assignment (B)

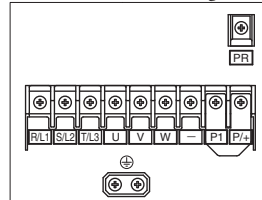

Mountain Hole Dimensions

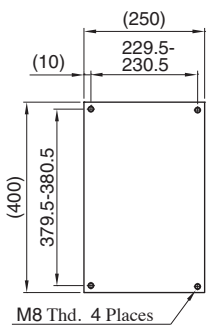

	Main Circuit Terminal R/L1, S/L2, T/L3, U, V, W, P/+, PR, ⊕	Control Circuit Terminal
Terminal Screw	M8	M6 M3.5
Torque [N·m]	7.8	4.4 1.2

* Note) Do not connect wiring to the terminals "P1" and "-".

M8 Thd. 4 Places

AMSE-4BB-B00-11

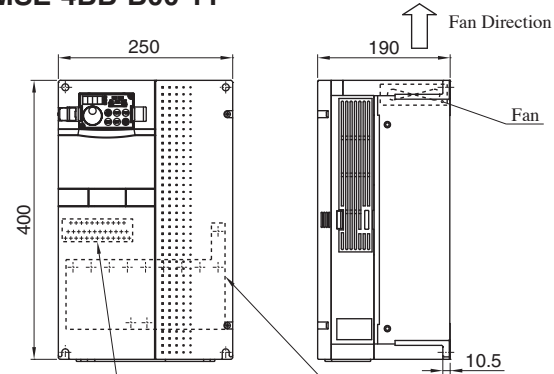

Control Circuit Terminal Assignment (A)

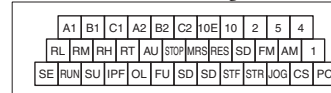

Main Circuit Terminal Assignment (B)

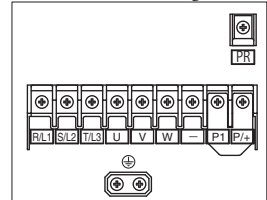

Mountain Hole Dimensions

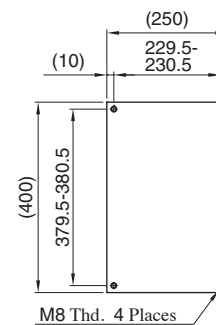

	Main Circuit Terminal R/L1, S/L2, T/L3, U, V, W, P/+, PR, ⊕	Control Circuit Terminal
Terminal Screw	M6	M3.5
Torque [N·m]	4.4	1.2

* Note) Do not connect wiring to the terminals "P1" and "-".

M8 Thd. 4 Places

AMSE- * DE-B00-10

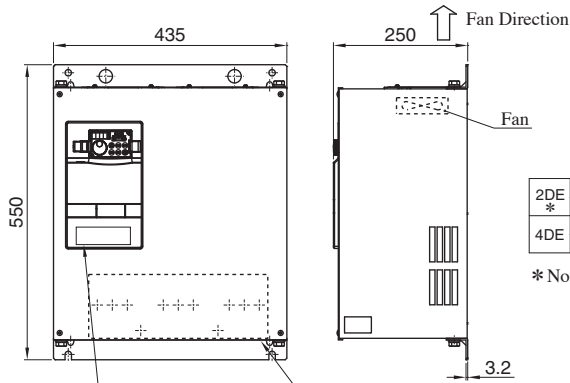

	Main Circuit Terminal U, V, W, P/+ , N/-, R/L1, S/L2, T/L3	Control Circuit Terminal
2DE	Terminal Screw M10	M8 M3.5
*	Torque [N·m] 14.7	7.8 1.2
4DE	Terminal Screw M8	M3.5
	Torque [N·m] 7.8	1.2

* Note) Do not connect wiring to the terminals "P1".

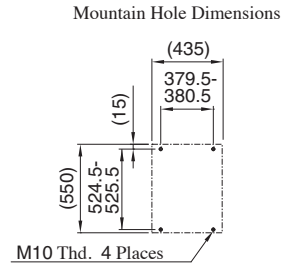

Control Circuit Terminal Assignment (A)

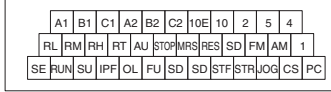

Main Circuit Terminal Assignment (B)

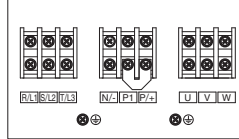

Installation Standard

**AMSE-2AE-
*BB-B00-***

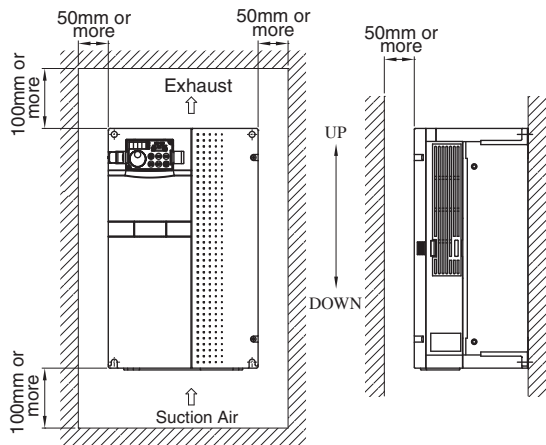

AMSE-4AE-B00-10

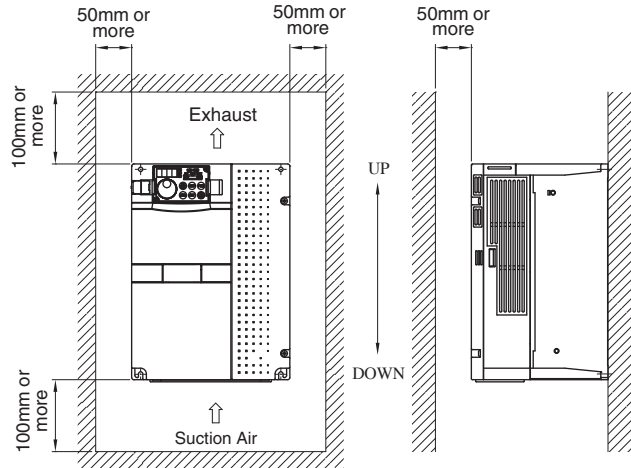

AMSE- * DE-B00-10

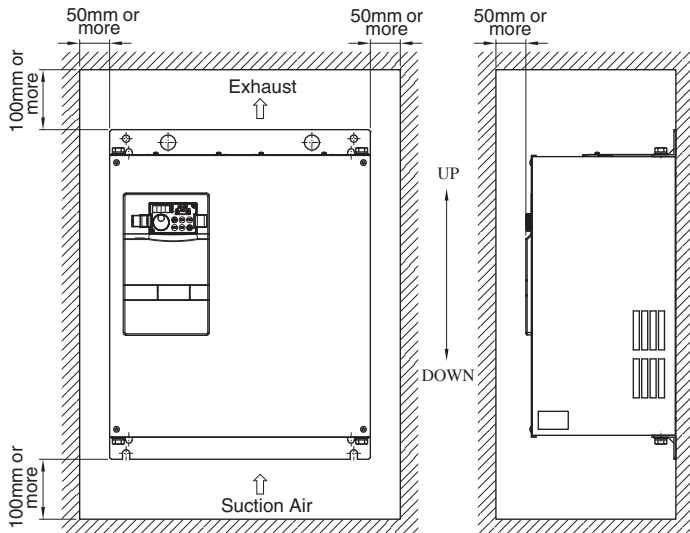

★Consult us when installing multiple controllers next to each other.

Terminal Names/Appearance

- AMSE-2AE -B00-10
- AMSE- *BB-B00-11

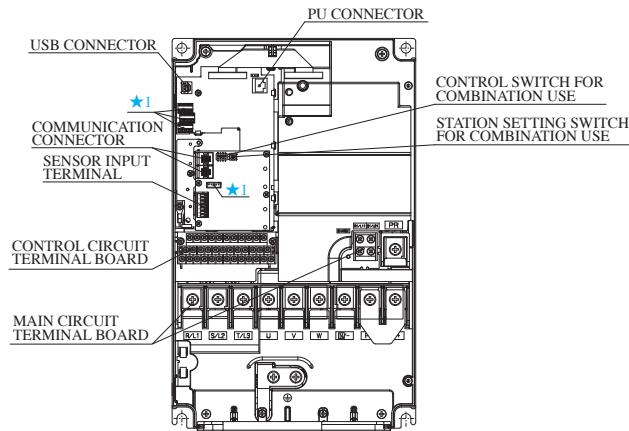

★1 These are not used in this system.

- AMSE-4AE -B00-10

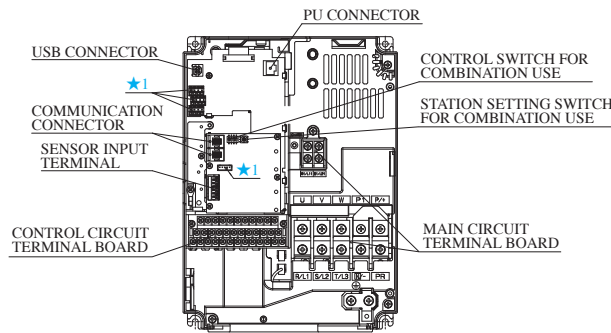

★1 These are not used in this system.

- AMSE- *DE-B00-10

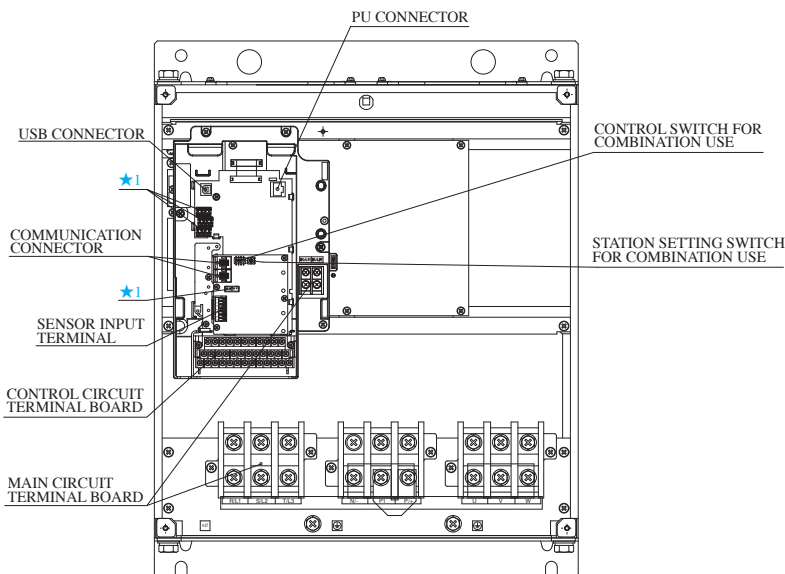

★1 These are not used in this system.

Function	Terminal Name	Terminal Channel	Description
Combination (Single Operation Allowed)	USB Connector (Type:USB B)	-	By using the serial communication function of USB, such as change of parameter, operation of monitor function is possible.
	Control Switch	1	For the manufacturer's setting. : Always OFF.
		2	Reserved.
		3	For switching single and combination operations. OFF: Combination, ON: Single
	Station Setting Switch	4	Network terminal resistance OFF:None, ON:Resistance
		0	Master station
	Communication Connector	1-F	Slave station
-		-	Connect this to the network of the ASE controller. Recommended cable: TEL-FST- * S (SANWA) or MJ-FS *(ELECOM)

Terminal Block

Connection (Use)	Signal Name	Description		
		AMSE- * AE/* BB-B00	AMSE-2DE-B00	AMSE-4DE-B00
DC Reactor for Power Factor Improvement	P1	No Connection★2		
Brake Unit	N/-	No Connection★2	FR-BU2-30K-04★2	FR-BU2-H30K-04★2

★2 Please contact Yuken, when you connect each unit or connect a DC reactor.

For the details of PU connector, sensor input terminal, consult us separately.

Wire Connection Diagram

ASE3-AA-*-B00-40**

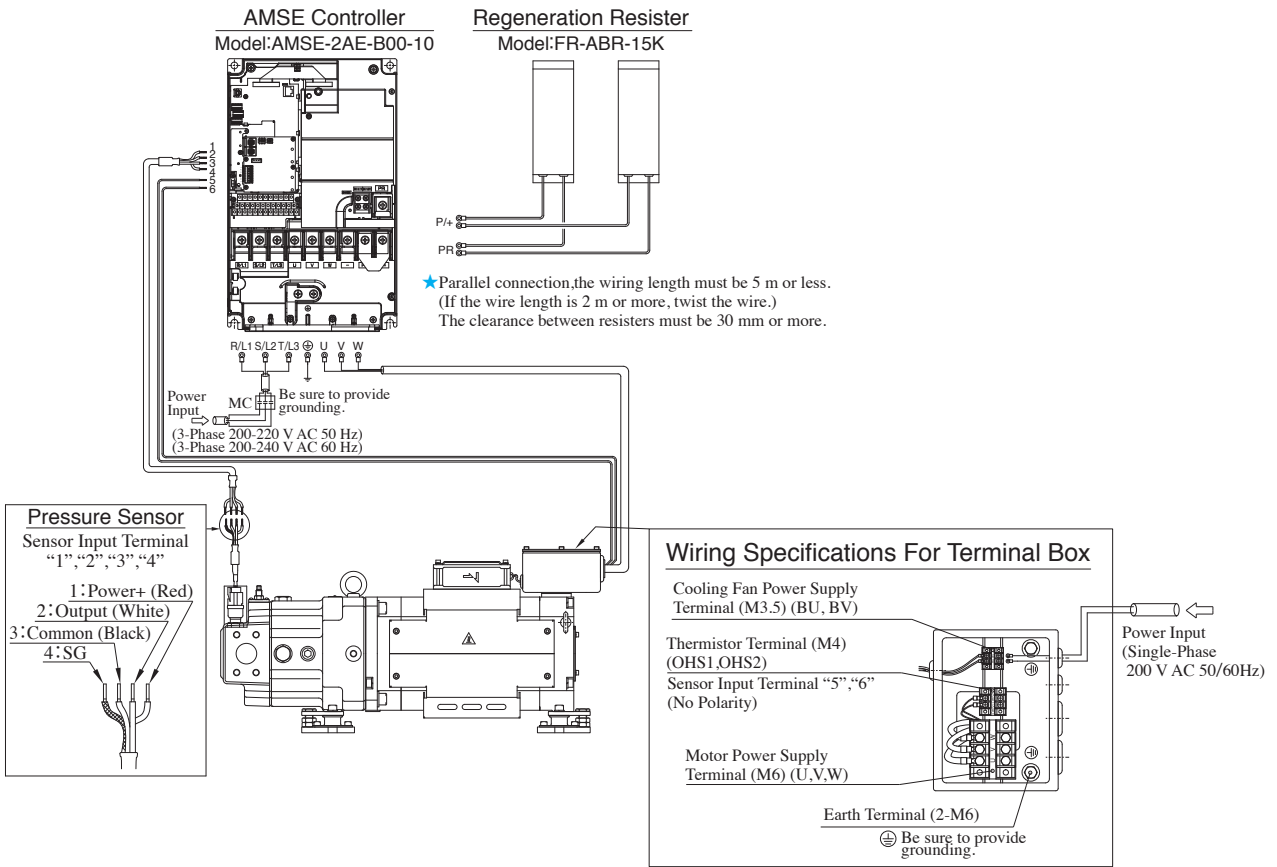

ASE3-4AA-*-B00-40**

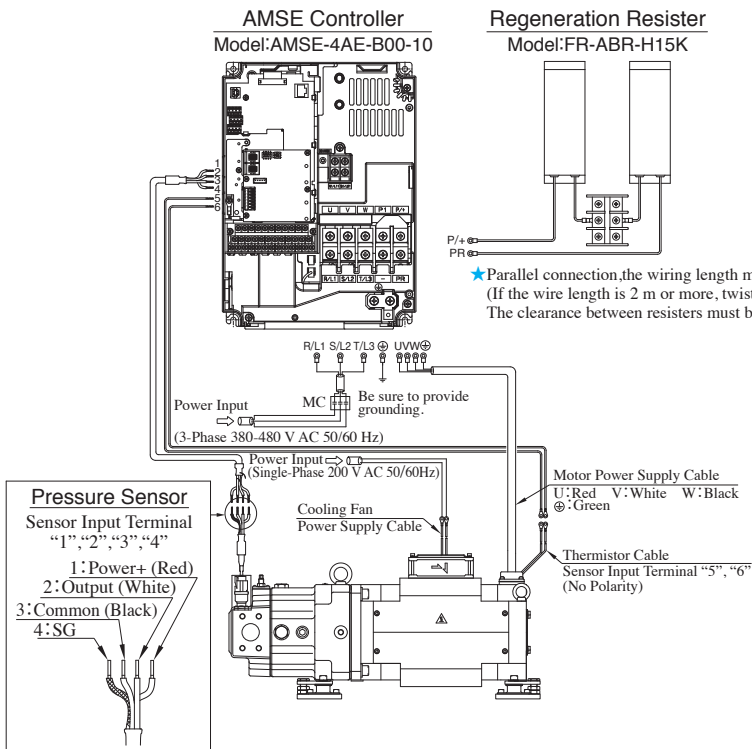

Wire Connection Diagram

ASE5-BZ-***-B00-40

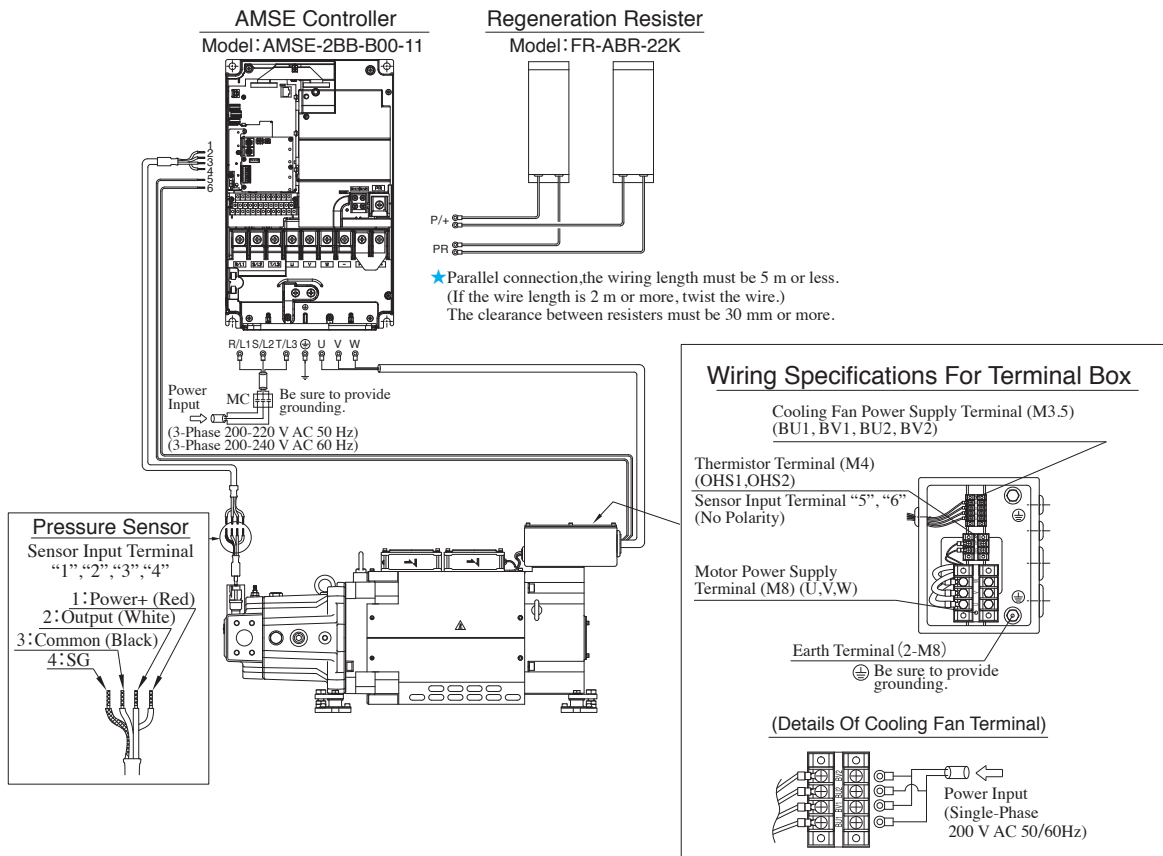

ASE5-4BZ-***-B00-40

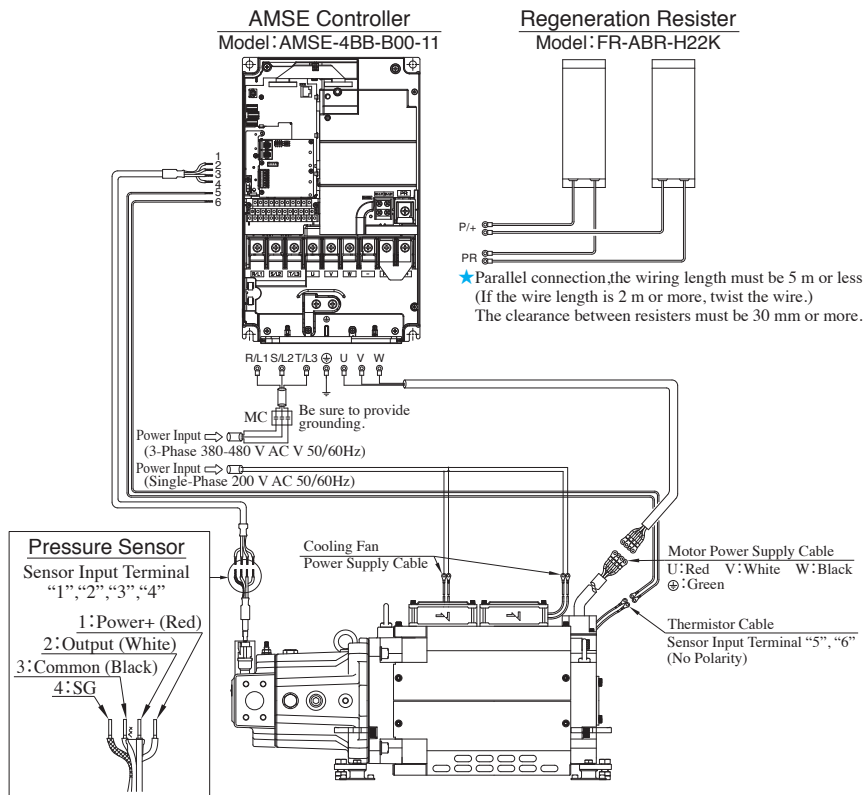

Wire Connection Diagram

ASE10-CE-*-B00-30**

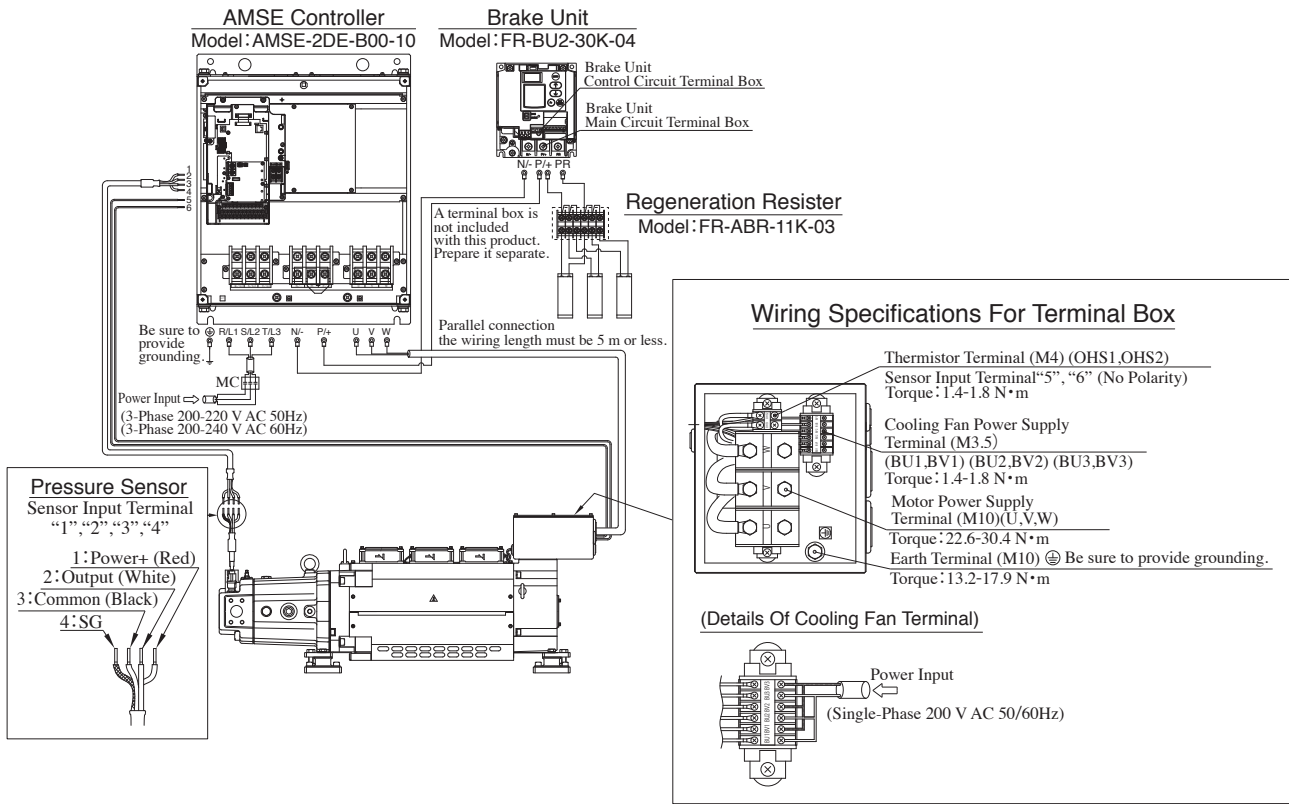

ASE10-4CE-*-B00-30**

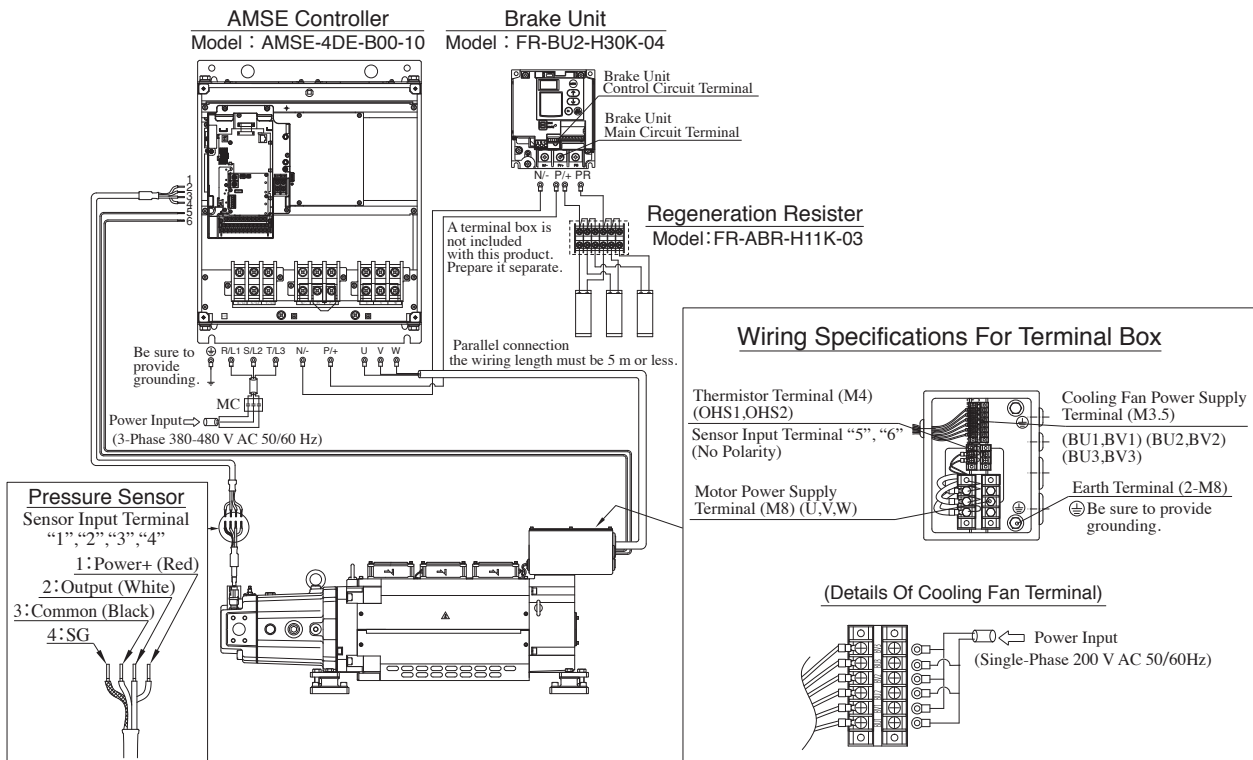

Wire Connection Diagram

ASE10W-BZ-G **** -B00-20

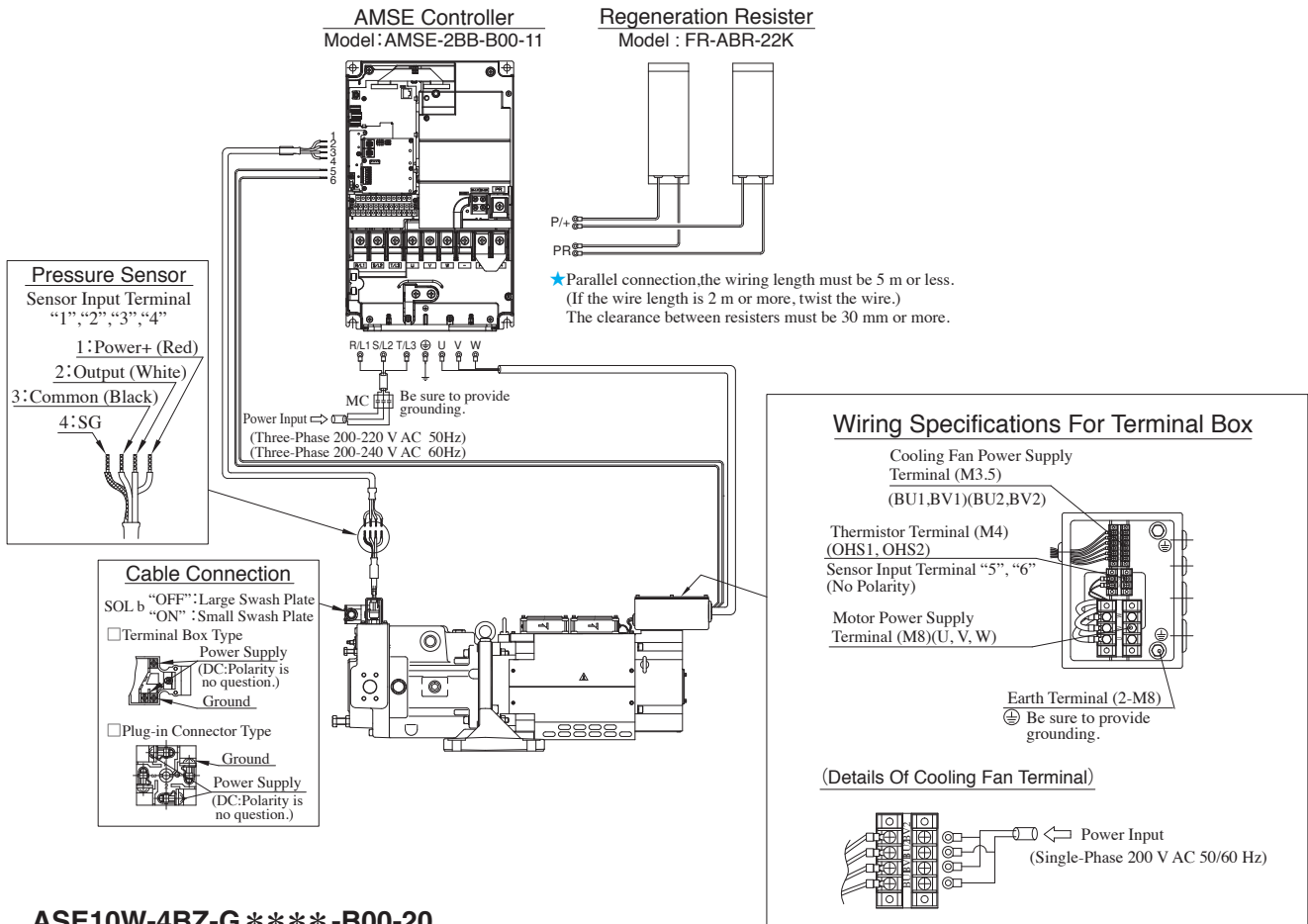

ASE10W-4BZ-G **** -B00-20

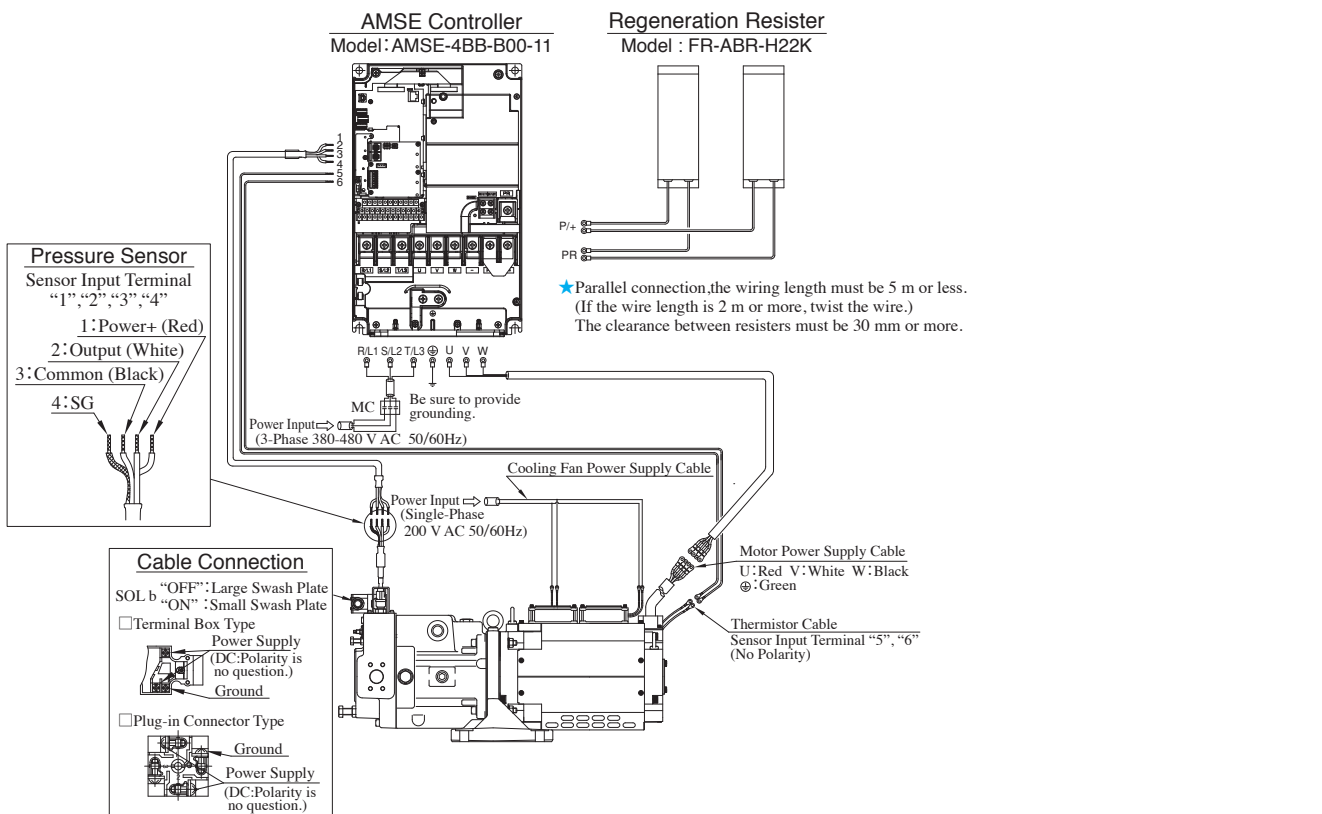

Wire Connection Diagram

ASE15W-4CE-G**-B00-20**

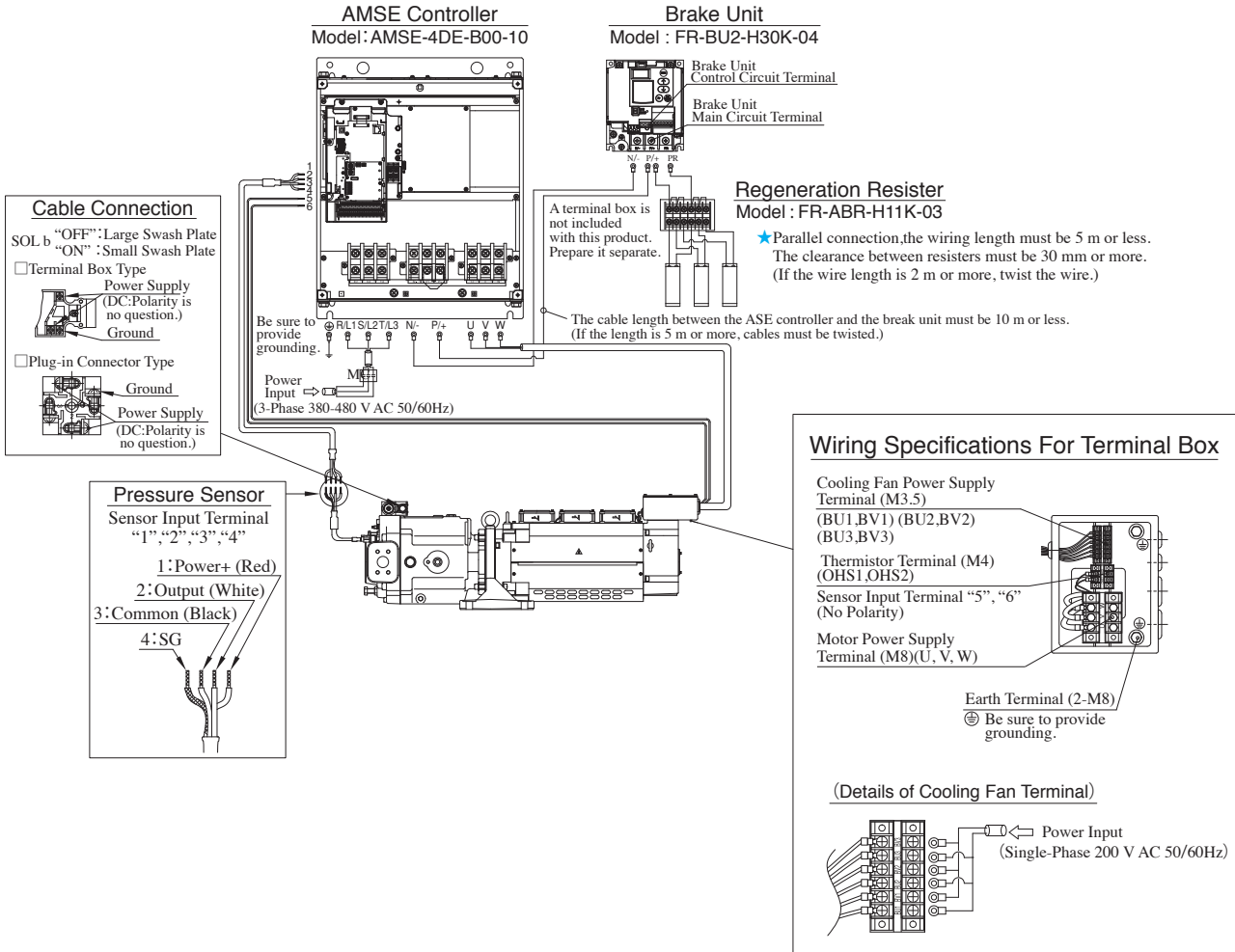

Cable Connection

SOL b "OFF" : Large Swash Plate
"ON" : Small Swash Plate

□ Terminal Box Type
Power Supply (DC: Polarity is no question.)
Ground

□ Plug-in Connector Type
Ground
Power Supply (DC: Polarity is no question.)

Pressure Sensor
Sensor Input Terminal
"1", "2", "3", "4"

1: Power+ (Red)
2: Output (White)
3: Common (Black)
4: SG

Wiring Specifications For Terminal Box

Cooling Fan Power Supply Terminal (M3.5)
(BU1, BV1) (BU2, BV2) (BU3, BV3)

Thermistor Terminal (M4)
(OHS1, OHS2)

Sensor Input Terminal "5", "6"
(No Polarity)

Motor Power Supply Terminal (M8)(U, V, W)

Earth Terminal (2-M8)
⊕ Be sure to provide grounding.

(Details of Cooling Fan Terminal)

Power Input (Single-Phase 200 V AC 50/60Hz)

Connectors

Control Circuit Terminal

	Cable mm ²
Control Circuit Terminal	0.75 (AWG18)

Sensor Input Terminal

	Cable mm ²
Pressure Sensor Thermistor	0.5 - 1.3 (AWG20 - 16)

Cooling Fan

	Cable mm ²
Cooling Fan Cable	2.0 (AWG14)

AMSE-2AE--10**

Main Circuit Terminal

	HIV Cable mm ²	AWG	PVC Cable mm ²
Main Circuit Power R/L1, S/L2, T/L3	22	4	25
Motor Output Power U, V, W	22	4	25
Regeneration Resister P/+, PR	2.1	14	2.5
Earth Wire ⊕	14	6	16

AMSE-4AE--10**

Main Circuit Terminal

	HIV Cable mm ²	AWG	PVC Cable mm ²
Main Circuit Power R/L1, S/L2, T/L3	8	8	10
Motor Output Power U, V, W	8	8	10
Regeneration Resister P/+, PR	2.1	14	2.5
Earth Wire ⊕	8	8	10

AMSE-2BB--11**

Main Circuit Terminal

	HIV Cable mm ²	AWG	PVC Cable mm ²
Main Circuit Power R/L1, S/L2, T/L3	38	2	35
Motor Output Power U, V, W	38	2	35
Regeneration Resister P/+, PR	2.1	14	2.5
Earth Wire ⊕	22	4	25

AMSE-4BB--11**

Main Circuit Terminal

	HIV Cable mm ²	AWG	PVC Cable mm ²
Main Circuit Power R/L1, S/L2, T/L3	14	6	16
Motor Output Power U, V, W	14	6	16
Regeneration Resister P/+, PR	2.1	14	2.5
Earth Wire ⊕	14	6	16

AMSE-2DE--10**

Main Circuit Terminal

	LMFC Cable mm ²	HIV Cable mm ²	AWG	PVC Cable mm ²
Main Circuit Power R/L1, S/L2, T/L3	60	100	4/0	95
Motor Output Power U, V, W ⊕ (Earth Terminal)	★60			
Brake Unit Regeneration Resister P/+, N/- (PR)		5.5	10	6
Earth Wire ⊕	38	60	4	50

AMSE-4DE--10**

Main Circuit Terminal

	HIV Cable mm ²	AWG	PVC Cable mm ²
Main Circuit Power R/L1, S/L2, T/L3	38	1	50
Motor Output Power U, V, W	38	2	50
Brake Unit Regeneration Resister P/+, N/- (PR)	3.5	12	4
Earth Wire ⊕	22	4	25

★Select LMFC wire for motor connection.

Recommended wire: EM-LMFC (Flame-retardant cross-linked polyethylene insulated flexible lead wire) made by Furukawa Electric Industrial Cable Co.,Ltd

● Pressure Sensor Cable
Consult us separately.

■ Regeneration Resister

● Specifications

AMSE Controller Model Numbers	Regeneration Resister Model	Qty.	Brake Unit Model	Permissible Regeneration W	Resistance Ω	Mass kg
AMSE-2AE-B00-	FR-ABR-15K	2		805	9 (18 Ω ×2 Parallel)	4.4kg (2.2kg×2)
AMSE-4AE-B00-	FR-ABR-H15K			870	36 (18 Ω ×2 Series)	
AMSE-2BB-B00-	FR-ABR-22K	2		1120	6.5 (13 Ω ×2 Parallel)	6.6kg (3.3kg×2)
AMSE-4BB-B00-	FR-ABR-H22K			1060	26 (52 Ω ×2 Parallel)	7.2kg (3.6kg×2)
AMSE-2DE-B00-	FR-ABR-11K-03	3	FR-BU2-30K-04	1500	4.3 (13 Ω ×3 Parallel)	9.6kg (3.2kg×3)
AMSE-4DE-B00-	FR-ABR-H11K-03		FR-BU2-H30K-04	1500	17.3 (52 Ω ×3 Parallel)	

- ★1. Regeneration resistors are included with the AMSE.
- ★2. Regeneration resistors may become excessively heated. Use heat-resistant and fireproof wires and avoid their contact with the resistors.
- ★3. The power (W) stamped on the regeneration resistor body is the rated value of the regeneration resistor alone, not the permissible regenerations power (W) shown in the table above.

Model:FR-ABR-15K/H15K

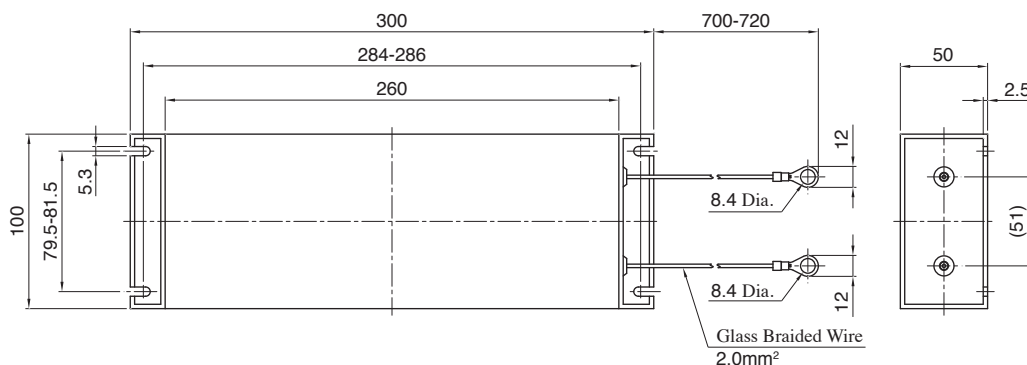

Model:FR-ABR-H22K

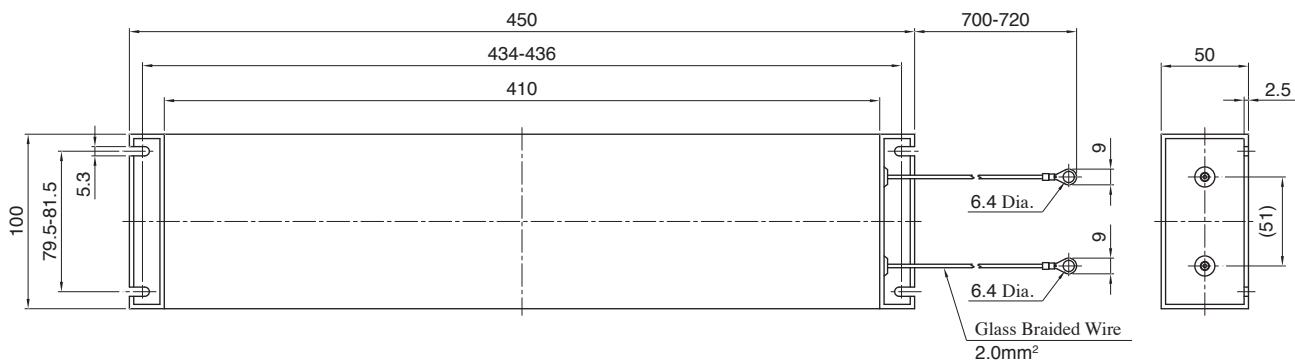

Model:FR-ABR-22K/11K-03/H11K-03

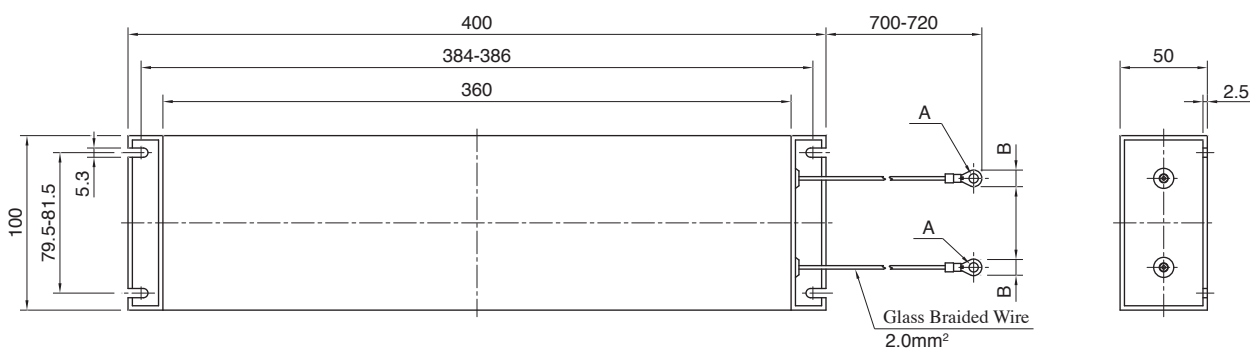

Model	A	B
FR-ABR-22K	8.4 Dia.	12
FR-ABR-11K-03/H11K-03	6.4 Dia.	9

● Customer Setting

FR-ABR-15K/22K/H22K

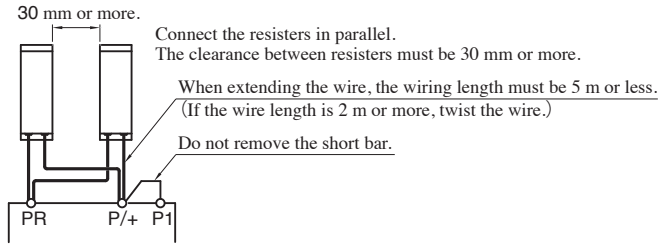

FR-ABR-H15K

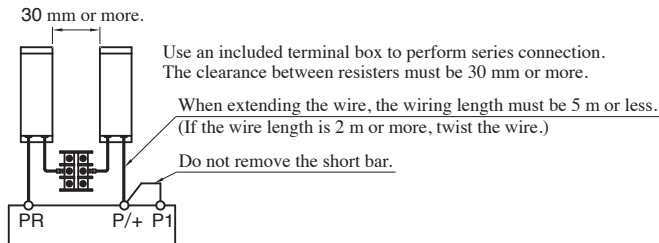

● Attachment

Terminal Box Outline Drawing

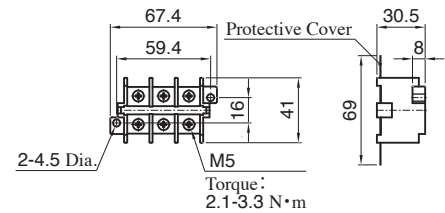

FR-ABR-11K-03 FR-ABR-H11K-03

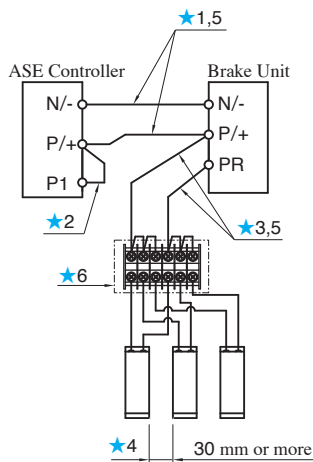

Brake Unit Outline Drawing

MODEL: FR-BU2-30K-04
FR-BU2-H30K-04

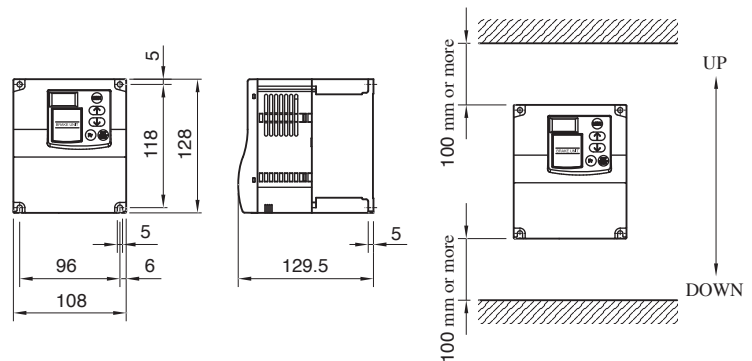

Main Circuit Terminal Assignment

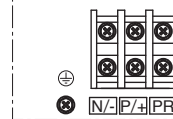

Control Circuit Terminal Assignment

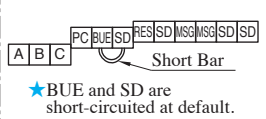

- ★1. The wiring length between the ASE controller and brake unit must be 10 m or less. (If it is 5 m or more, twist the wire.)
- ★2. Do not remove the short bar between terminals P1 and P/+ of the ASE controller.
- ★3. The wiring length between the brake unit and regenerative resistor must be 5 m or less. (If the wire length is 2 m or more, twist the wire.)
- ★4. Connect the resistors in parallel. The clearance between resistors must be 30 mm or more.
- ★5. Use a wire with the size indicated below or larger.
HIV wires and the like: 5.5 mm² AWG-10, PVC wires and the like: 6 mm² [FR-BU2-30K-04]
HIV wires and the like: 3.5 mm² AWG-12, PVC wires and the like: 4 mm² [FR-BU2-H30K-04]
- ★6. A terminal box is not included with this product. Prepare it separately.

MODEL:FR-BU2-30K-04

	MAIN CIRCUIT TERMINAL	CONTROL CIRCUIT TERMINAL
	P/+, N/-, PR, ⊕	
TERMINAL SCREW	M5	M3
TIGHTENING TORQUE	2.5 [N·m]	0.6 [N·m]

MODEL:FR-BU2-H30K-04

	MAIN CIRCUIT TERMINAL	CONTROL CIRCUIT TERMINAL
	P/+, N/-, PR, ⊕	
TERMINAL SCREW	M4	M3
TIGHTENING TORQUE	1.5 [N·m]	0.6 [N·m]