

## Low-Noise Compact Type Standard Hydraulic Power Unit YP Pack

YP pack is low-noise & compact unit equipped with PAL pump of excellent performance as power resource. It saves floor space for installation by compact design. And YUKEN has achieved noise level 55 dB(A) comfortable never before.

### ● Low Noise & Low Vibration

Equipped with low-noise PAL pump and drain cooler. Also, low noise and vibration levels have been achieved by effectively arraying the components to control vibration.

### ● Compact Design

YP pack is well designed to be compact by uprighting the PAL pump and reducing the fluid temperature rise ratio added small size reservoir. It saves floor space for installation.

### ● Low Fluid Temperature Rise

Standard equipment, built-in drain cooler and radiator fins of PAL pump, reduce the fluid temperature rise ratio. Good solution for heat distortion of machines.

### ● Wide Range

YP packs offer nine different models in variety. Seven kinds of options are available such as YP pack with control circuit consists of modular & solenoid operated directional valve.

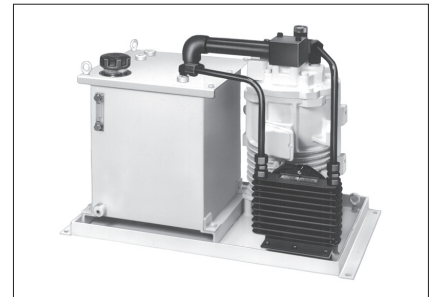

Hydraulic Circuit

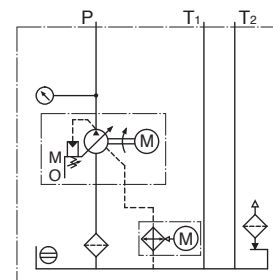

### ■ Specifications

Model Numbers	Geometric Displacement of Pump cm <sup>3</sup> /rev	Max. Operating Pres. MPa	Pres. Adj. Range MPa	Reservoir Capacity L	Electric Motor		Approx. Mass kg (excluding hydraulic fluid)		
					50 Hz : 200 V AC	60 Hz : 200 V/220 V AC			
YP10-B-1-0.75-23	10.0	7	B : 1.2 - 7	10	0.75 kW×4P		63		
YP10-* -1-1.5-23				10	1.5 kW×4P			B:73 C:68	
YP16-* -1-1.5-22	15.8	16	B : 1.2 - 7 C : 2 - 16	10	1.5 kW×4P		80		
YP16-* -1-2.2-22				10	2.2 kW×4P			90	
YP16-* -2-2.2-22				20	2.2 kW×4P		90		
YP22-* -2-2.2-22				20	2.2 kW×4P			90	
YP22-* -3-3.7-22	22.2			16	B : 1.2 - 7 C : 2 - 16	30	3.7 kW×4P		110
YP37-* -3-3.7-22						30	3.7 kW×4P		
YP37-* -3-5.5-22						30	5.5 kW×4P		150

### ● Drain Cooler Electric Specifications

- 50 Hz : 200 V AC (Single Phase), 28 W
- 60 Hz : 200 V AC (Single Phase), 26 W
- 60 Hz : 220 V AC (Single Phase), 31 W
- Lead Wire Length : 3 m

### ■ Model Number Designation

YP	16	-B	-1	-2.2	-22
Series Number	Built-in Pump	Pres. Adj. Range MPa	Reservoir Capacity L	Electric Motor	Design Number
YP : Low-Noise Compact Type Standard Hydraulic Power Unit YP Pack	10 : PM10 (10.0 cm <sup>3</sup> /rev)	B : 1.2 - 7	1 : 10	0.75 : 0.75 kW×4P	23
			1 : 10	1.5 : 1.5 kW×4P	
	16 : PM16 (15.8 cm <sup>3</sup> /rev)	B : 1.2 - 7	1 : 10	1.5 : 1.5 kW×4P	22
			2 : 20	2.2 : 2.2 kW×4P	
			2 : 20	2.2 : 2.2 kW×4P	
			3 : 30	3.7 : 3.7 kW×4P	
	22 : PM22 (22.2 cm <sup>3</sup> /rev)	C : 2 - 16	2 : 20	2.2 : 2.2 kW×4P	22
			3 : 30	3.7 : 3.7 kW×4P	
	37 : PM37 (36.9 cm <sup>3</sup> /rev)	C : 2 - 16	3 : 30	3.7 : 3.7 kW×4P	22
			3 : 30	5.5 : 5.5 kW×4P	

## Options

### 1 Base Plate Embedded : 01M\*

Control circuit can be constructed by just stacking up modular valves/ solenoid valve atop the base plate. However, the circuit construction is limited to modular valves and standard solenoid directional control valves. In this case, please, indicate power supply for operation.

### 2 Pressure Gauge and Mounting Block Embedded : G2, G3

Use in case that detect the pressure except pump discharge pressure by using reducing valve.

G2 is able to detect one more line pressure, G3 is able to detect two more lines except pump discharge pressure.

### 3 Return Filter Embedded : F

Return filter adopt the tank top type those surge pressure of tank line lower generate. The absolute filtration is 20 μm, equipped with visual indicator.

### 4 Tank Magnet Embedded : Mg

Installed inside the tank. Attracts and collects fine iron powder. Decreases component wear.

### 5 Oil Level Gauge with Thermometer Embedded : Te

### 6 Thermostat Embedded : TR

### 7 Liquid Level Switch Embedded : Le

### 8 External Paint Color Changed : PT

The standard models are painted by Munsell 2.5Y9/2, color code H22-90D. In case if required special paint, please indicate separately by JPMA code or Munsell value.

### 9 Water Leak Inspection : RK

YUKEN conduct water leak inspection of tank.

### 10 Different Voltage Electric Motor : (\*V\*Hz)

200 V AC (50Hz) and 200/220/230 V AC (60Hz) are standard. In case if required other voltage, please indicate voltage and frequency. In case of 50Hz, choose from 230/380/400/415 V, in case of 60 Hz, choose from 400/440/460 V.

The drain cooler has no different voltage specifications, so please prepare another power supply of single phase 200 V AC (50Hz) or 200/220 V AC (60Hz) on the machine side.

## Applicable Options Table

Available options are indicated with ○ mark.

Option Code	01M*	G*	F	Mg	Te	TR	Le	PT	RK	*V*Hz
Option Item	1 Base Plate Embedded / Number of Base Plate Stations	2 Pressure Gauge Embedded	3 Return Filter Embedded	4 Tank Magnet Embedded	5 Oil Level Gauge with Thermometer Embedded	6 Thermostat Embedded	7 Liquid Level Switch Embedded	8 External Paint Color Changed	9 Water Leak Inspection	10 Different Voltage Electric Motor
Model										
YP10-B-1-0.75-23	○ 1 to 3 Stations	○ G2 G3	×	○	○	○	○	○	○	50 Hz : 230/380/400/ 415 V 60 Hz : 400/440/460 V
YP10-* -1-1.5-23			×	○	○	○	○	○	○	
YP16-* -1-1.5-22			×	○	○	○	○	○	○	
YP16-* -1-2.2-22			○	○	○	○	○	○	○	
YP16-* -2-2.2-22			○	○	○	○	○	○	○	
YP22-* -2-2.2-22			○	○	○	○	○	○	○	
YP22-* -3-3.7-22			○	○	○	○	○	○	○	
YP37-* -3-3.7-22			○	○	○	○	○	○	○	
YP37-* -3-5.5-22			○	○	○	○	○	○	○	

## Option Indication Method

When ordering YP Pack with options, please add [OP] at the end of standard YP Pack model number, use the example below for reference and indicate options. For summary of options, please refer to the above table.

### [Example of Option Indication]

YP16-B-1-2.2-22-OP

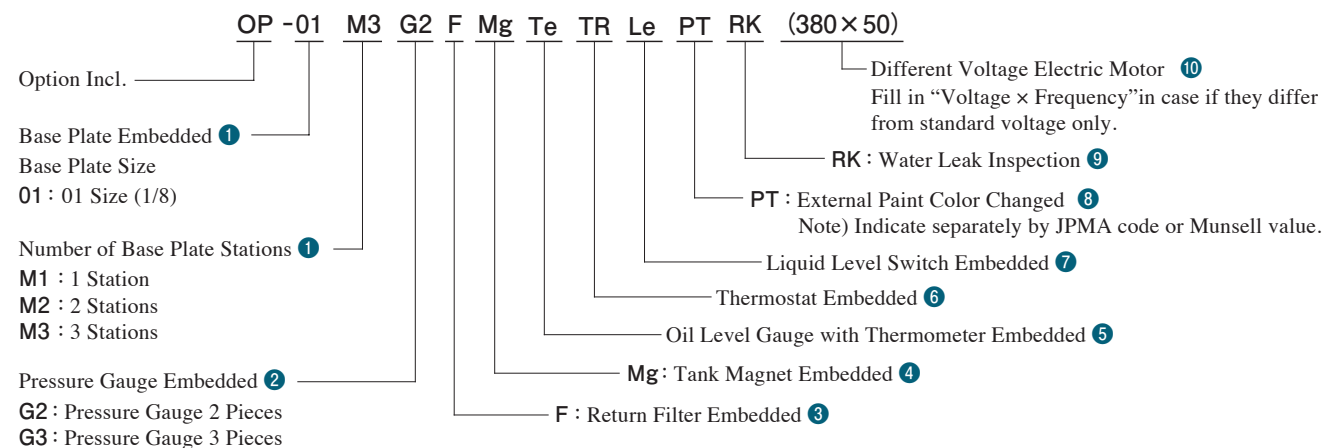

## Instructions

### Suction/Return Air

Don't put any obstructions at air vent surface of the drain cooler.  
Please install unit at the floor with good air flow to avoid heat stuff.

### Transportation

Use eye bolts at the time of transportation.

### Installation

This unit is stationary type, so please fix it using bolts on the level space with no vibration.

### Electrical Wiring

To protect electrical circuit from over current like short and protect motor from overload, we recommend to install no-fuse breaker with earth leakage breaker on the primary power supply.

For electrical wiring, please use crimp terminals of suitable size, and connect certainly to avoid electric leakage for main body and interphase electrical short. Please be sure to ground the earth terminal.

### [Terminal Box Detail]

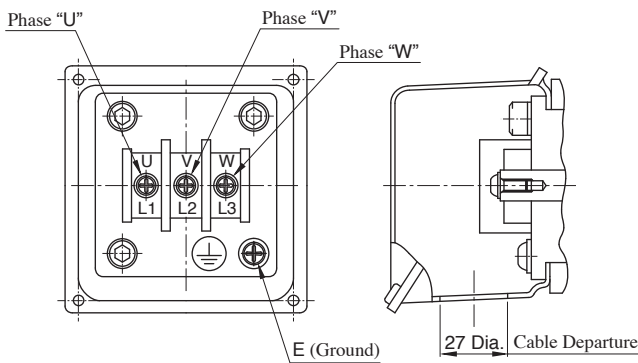

### [Connecting Screw Size : ]

Phase "U" "V" "W" M 4

E (Ground) M 6 Motor Side

U - R
V - S
W - T

Power Supply Side

### Note for Starting Operation

Before initial operation, please supply ruled mass of hydraulic fluid required from oil tank port, and fill clean hydraulic fluid from filling port of pump. Be sure to confirm that all of hydraulic circuits and electrical circuits have already prepared for starting operation. To avoid air-bound at starting operation, please adjust hydraulic circuit as that pump drain fluid return directly to oil tank, or operate directional valves for actuators no-load moving. When operate pump, also have to operate drain cooler.

There are cases when pressure increasing take time to drain air from pump or pipes. If after five minutes, the pressure does not yet increase, it may possible of motor reverse rotation, please cut off the power and check wiring.

### Air Vent

Because air entrainment in pump or pipe may cause to occur vibration, please make air vent completely.

### Setting of Pressure and Output Flow [Pressure Adjustment]

At the time of shipping, the pressure set at minimum level, so please adjust the pressure under using conditions. Turn the pressure adjustment screw clockwise, the pressure increase. For adjustment volumes at one rotation of adjustment screw, please refer to the table below. After adjustments, do not forget to tighten the lock nut.

### [Adjustment Volumes at One Rotation of Pres. Adj. Screw]

Model Numbers	Adjustment Volumes MPa
YP10/16/22-B	2.9
YP10/16/22-C	5.4
YP37-B	3.5
YP37-C	6.5

### [Output Flow Adjustment]

Turn the flow adjustment screw clockwise, the output flow decrease. For adjustment volumes at one rotation of adjustment screw, please refer to the table below. After adjustments, do not forget to tighten the lock nut.

### [Adjustment Volumes at One Rotation of Discharge Volume Adj. Screw]

Model Numbers	Adjustment Volumes at One Rotation cm <sup>3</sup> /rev	Min. Adj. Flow cm <sup>3</sup> /rev
YP10	1.1	2
YP16	1.5	6
YP22	2.1	8.5
YP37	2.9	10

## Interchangeability between Current and New Models

As of YP 10 type model, the design number has changed from 22 to 23 due to change of built-in pump.

### Change Details

Pressure adjustment range "B" mass increased 4kg.

Current		New	
Model Numbers	Mass kg	Model Numbers	Mass kg
YP10-B-1-0.75-22	58	YP10-B-1-0.75-23	63
YP10-B-1-1.5-22	68	YP10-B-1-1.5-23	73

★YP10-C-1.1.5 has no change, but the design number also change to 23.

### Interchangeability in Installation

Yes

### Specifications / Dimensions / Performance

Those of current and new models are same, except for the mass.

The characteristics below are the typical ones under viscosity 32 mm<sup>2</sup>/s (ISO VG32 oils, oil temperature 40°C )

**Selection Graph**

Below  portion of the graph is the allowable operating range with regards to rated output of electric motor.

Note ) ---- Lines of graphs indicate under minimum adjustment flow rate of pump. If use under minimum adjustment flow rate, please contact us.

**YP10**

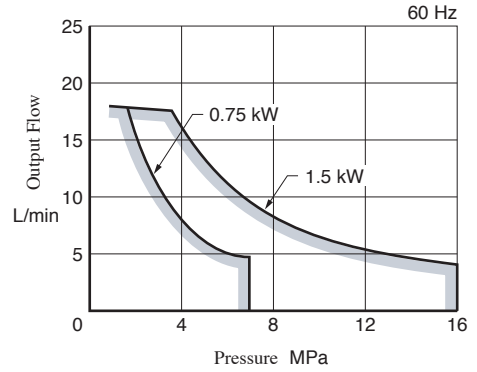
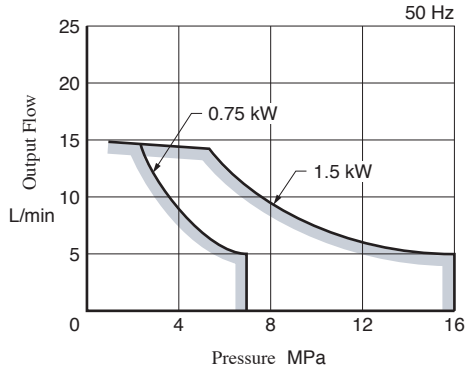

**YP16**

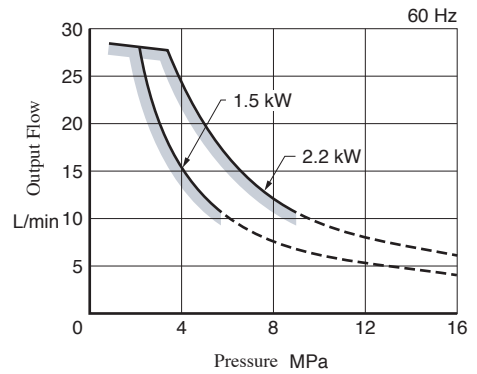
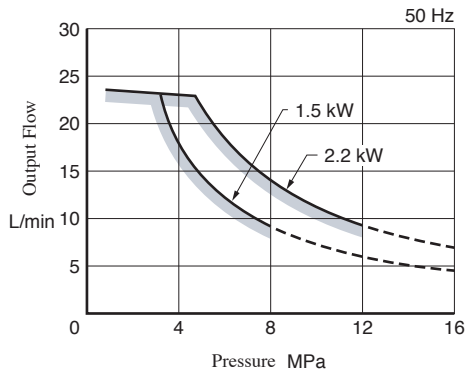

**YP22**

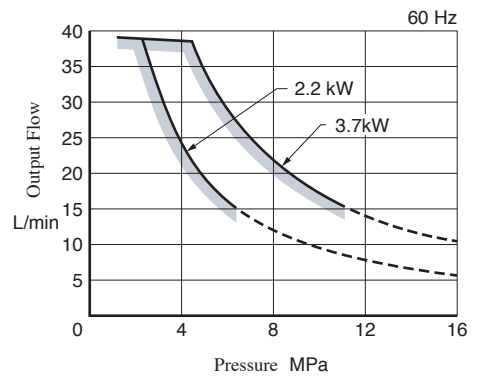
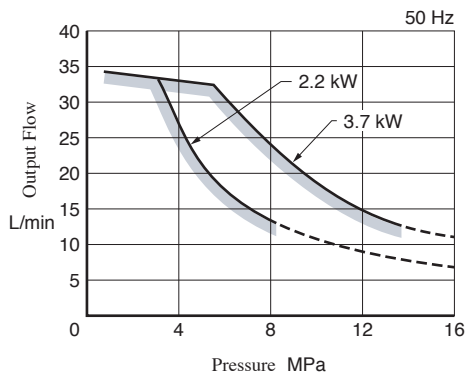

**YP37**

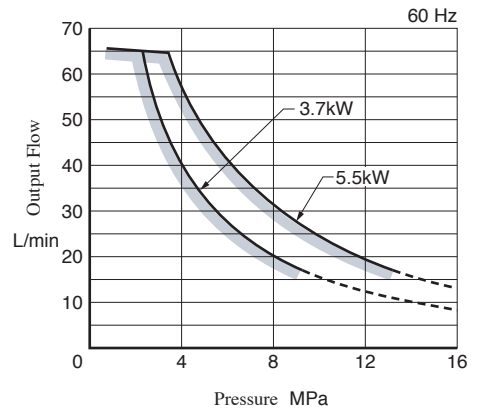
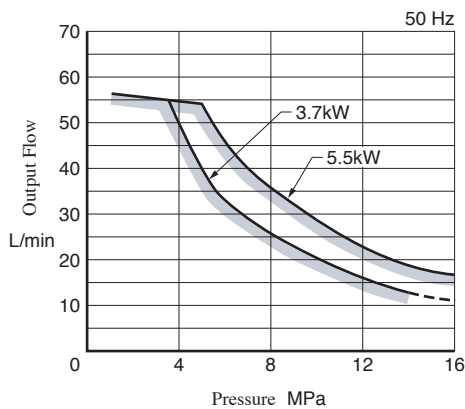

## Oil Temperature in Reservoir (full cut-off pressure)

Oil temperature is expressed as (room temperature + temperature rise value). Temperature rise values (full cut-off continuous operation, windless conditions) for each model are shown below, please, check that oil temperature is below 60°C.

Note) When operating YP10-B-1-0.75 continuously (50Hz) at full cut-off pressure 5MPa, temperature rise value is 12°C as shown by broken line in the graph. Assuming that room temperature is 35°C then tank temperature will be 47°C.

### ● YP10-B-1-0.75

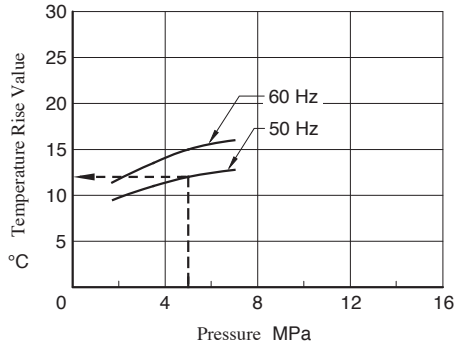

### ● YP10-C-1-1.5

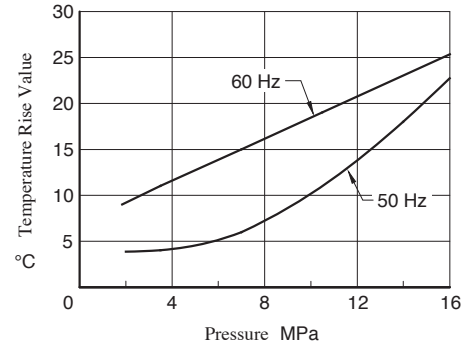

### ● YP16- \*-1-1.5

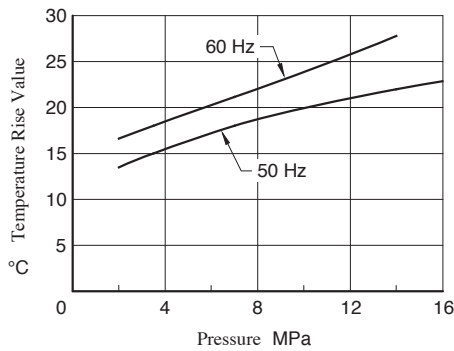

### ● YP16- \*-1-2.2

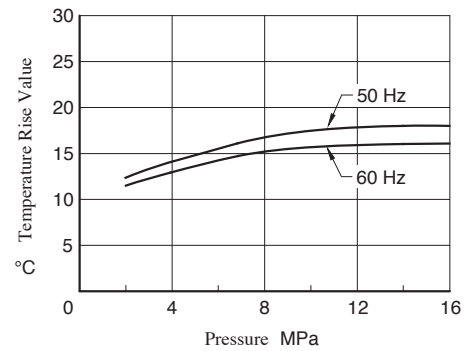

### ● YP16- \*-2-2.2

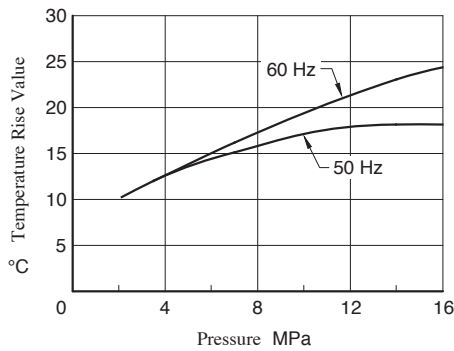

### ● YP22- \*-2-2.2

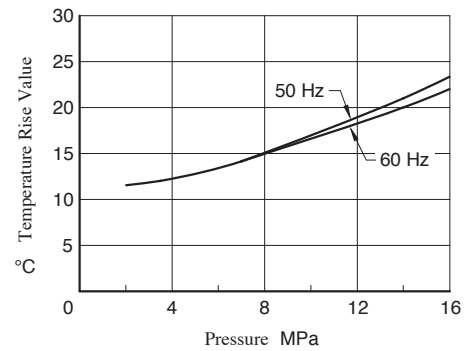

### ● YP22- \*-3-3.7

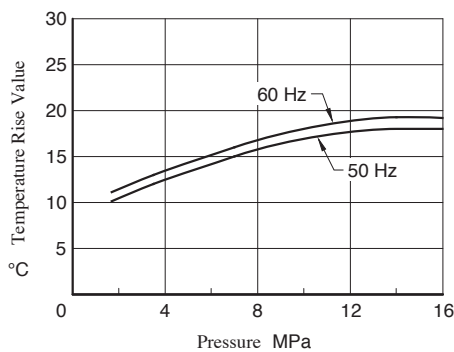

### ● YP37- \*-3-3.7/5.5

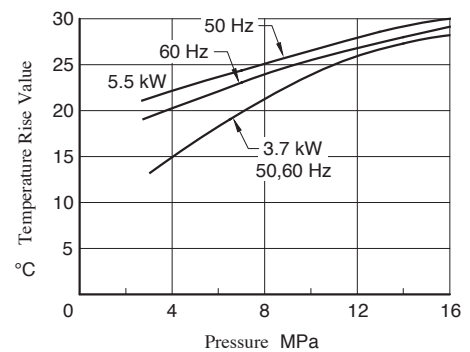

The characteristics below are the typical ones under viscosity 32 mm<sup>2</sup>/s (ISO VG32 oils, oil temperature 40°C)

■ Noise Characteristics (Example) (Location of Measurement: 1m from the pump)

● YP10-B-1-0.75

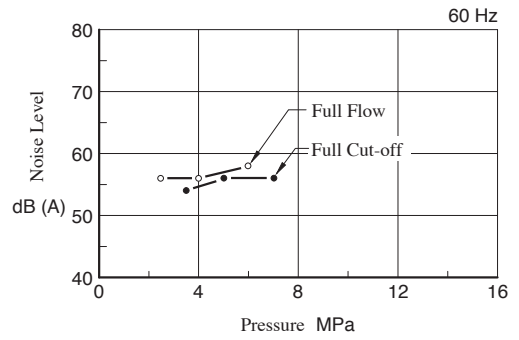
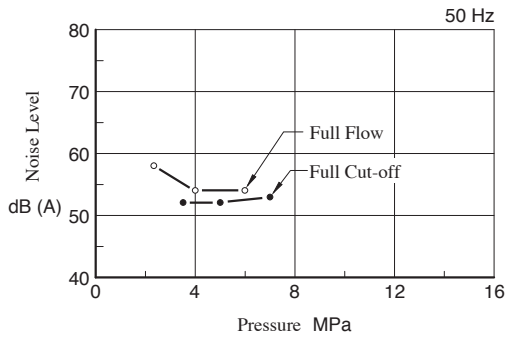

● YP10- \*-1-1.5

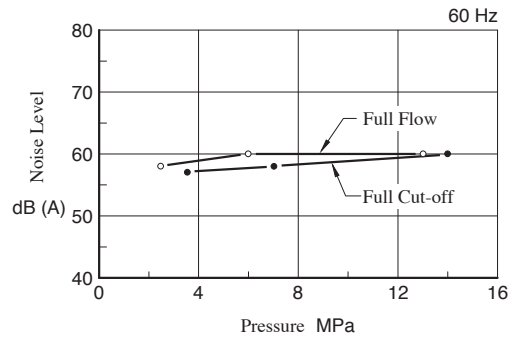
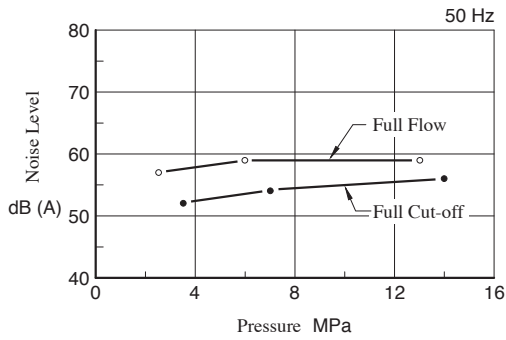

● YP16- \*-1-1.5

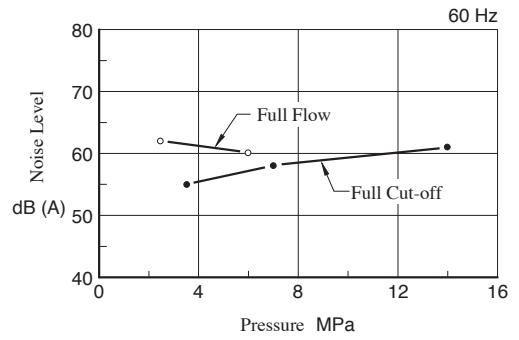
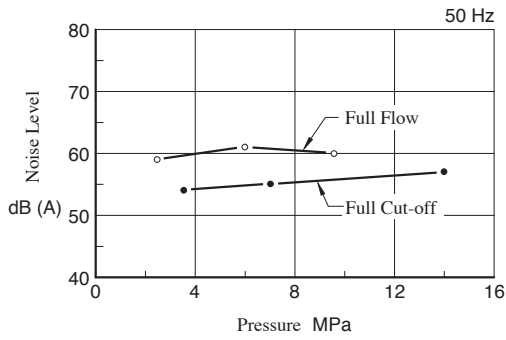

● YP16- \*-1-2.2

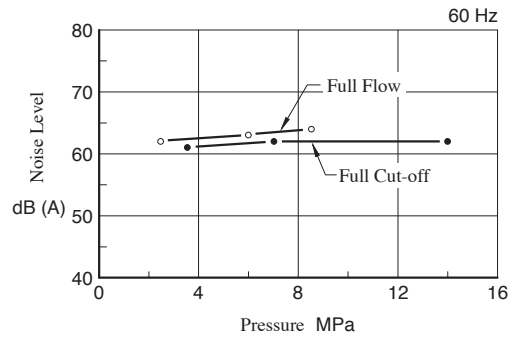
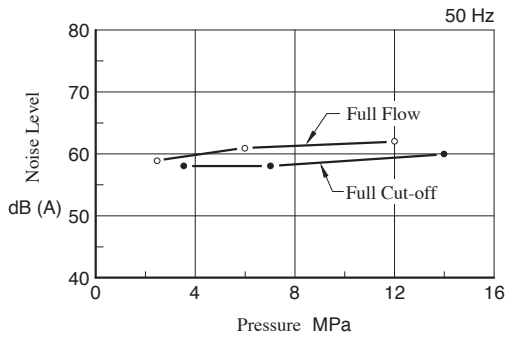

The characteristics below are the typical ones under viscosity 32 mm<sup>2</sup>/s (ISO VG32 oils, oil temperature 40°C)

■ Noise Characteristics (Example) (Location of Measurement: 1m from the pump)

● YP16/22- \*-2-2.2

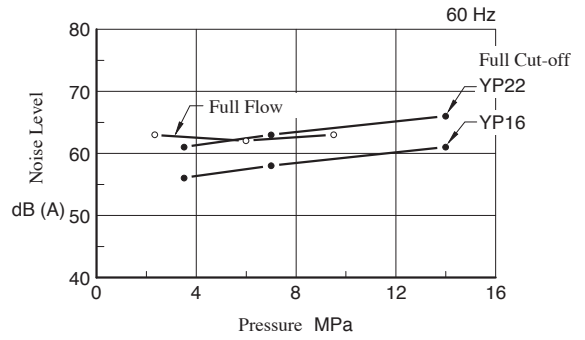
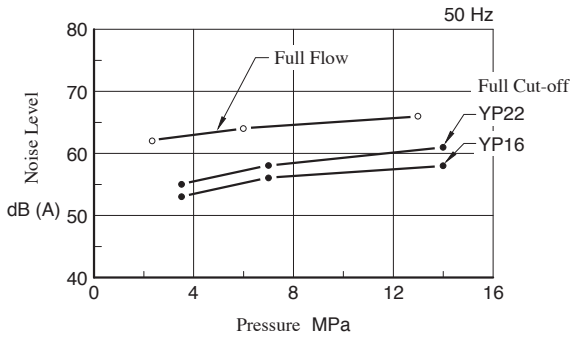

● YP22- \*-3-3.7

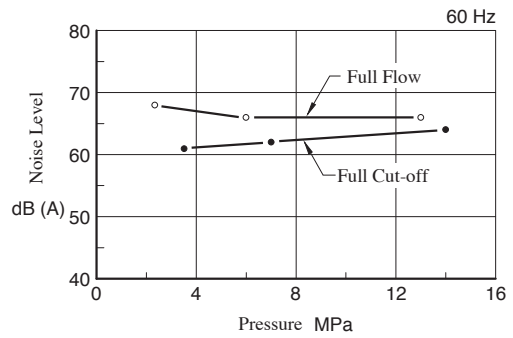
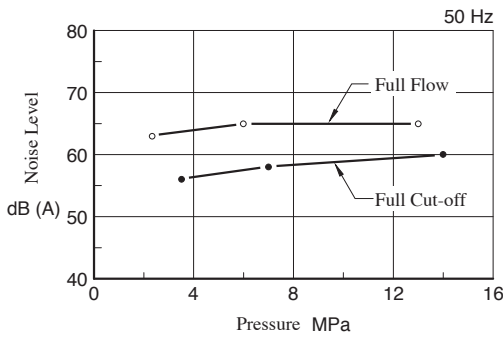

● YP37- \*-3-3.7

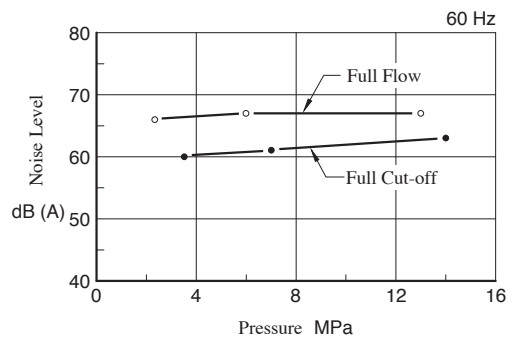
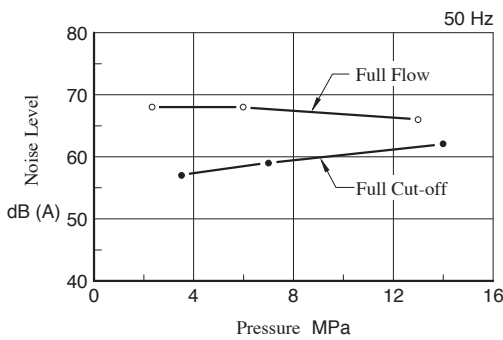

● YP37- \*-3-5.5

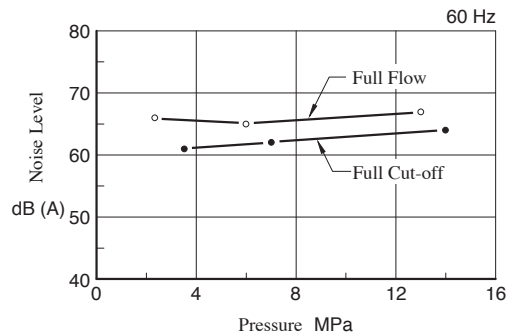
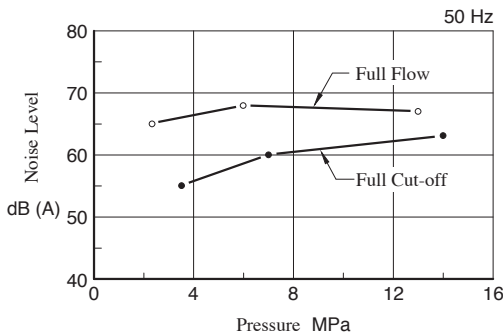

**YP10-B-1-0.75-23**

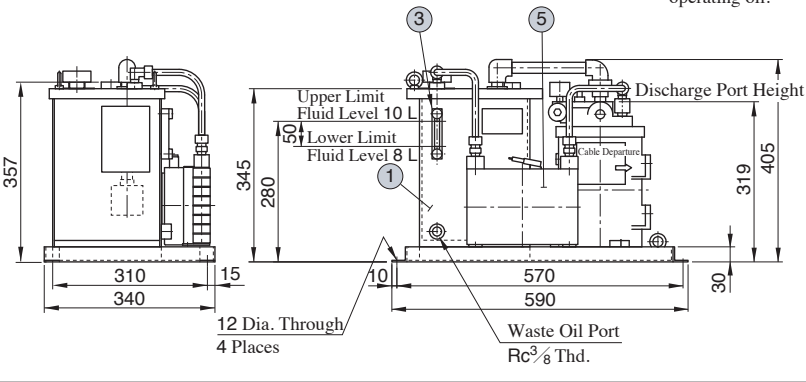
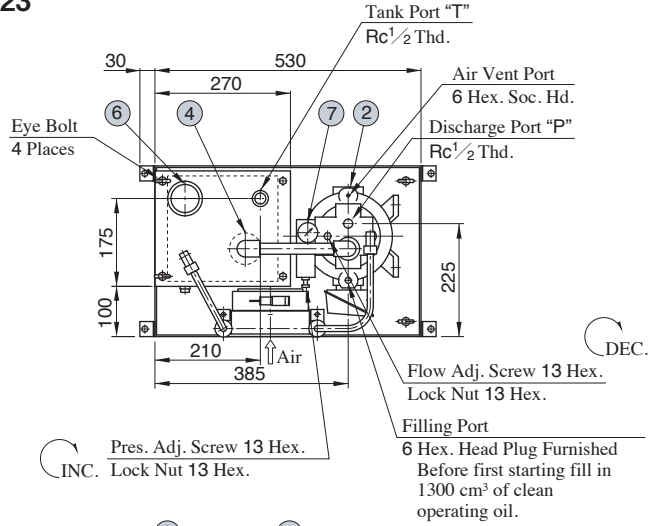

**Hydraulic Circuit**

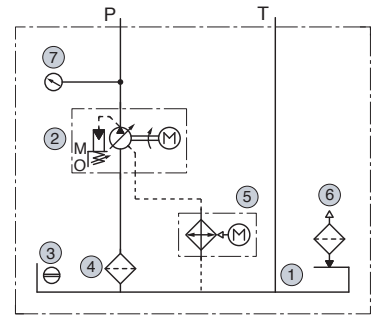

**YP10-\* -1-1.5-23**

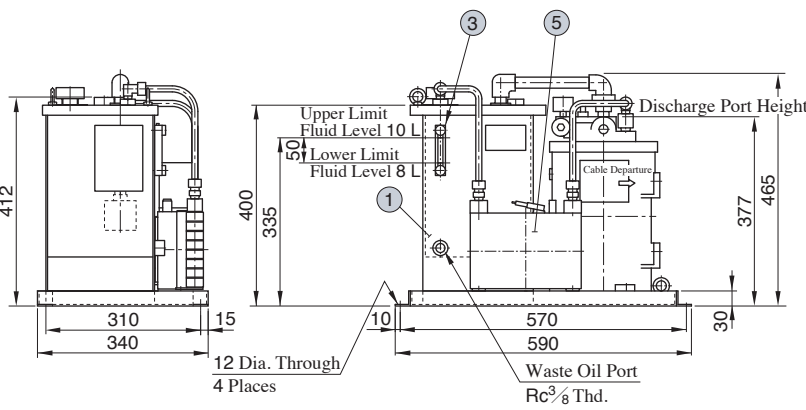
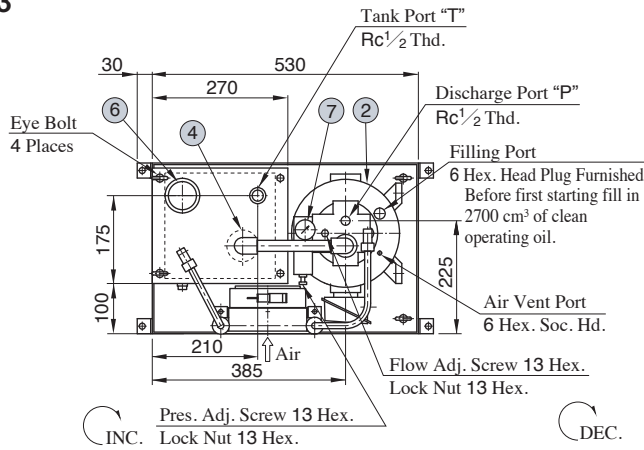

Item	Name
1	Hydraulic Reservoir
2	Pal Pump
3	Oil Level Gauge
4	Suction Strainer
5	Drain Cooler
6	Air Breather with Filling Port
7	Pressure Gauge



YP16-\*\*-1-1.5-22  
YP16-\*\*-1-2.2-22

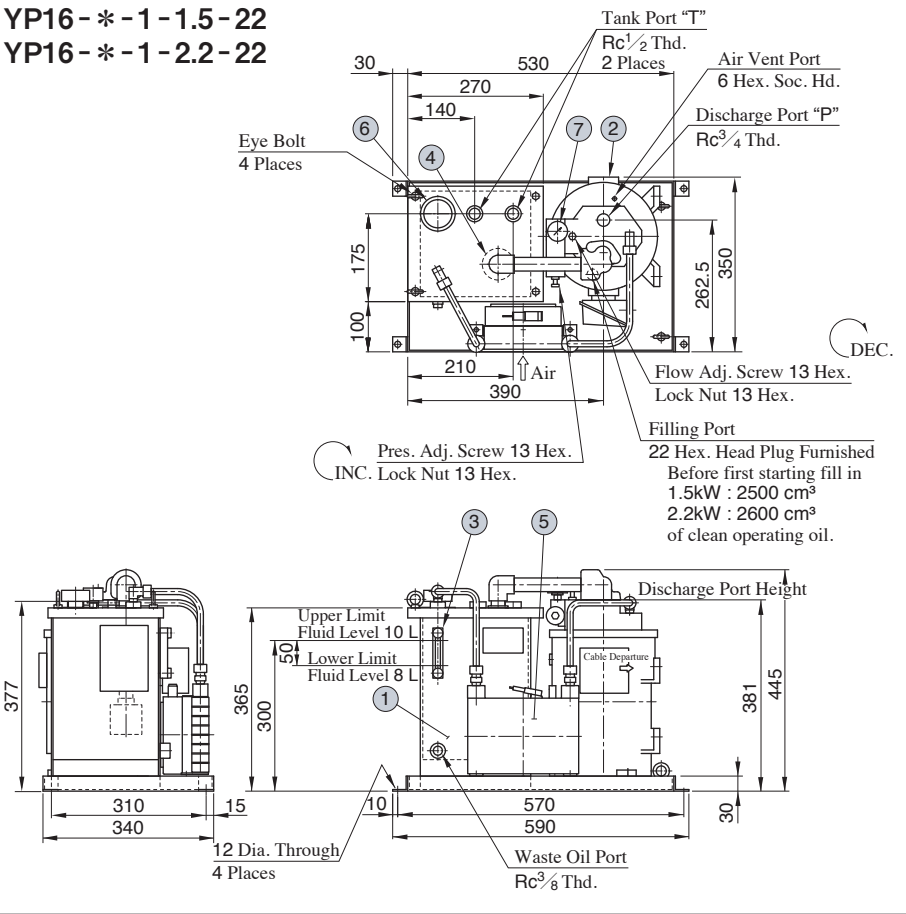

● Hydraulic Circuit

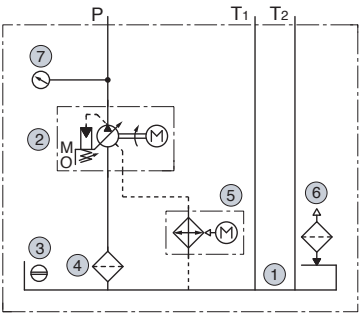

YP16/22-\*\*-2-2.2-22

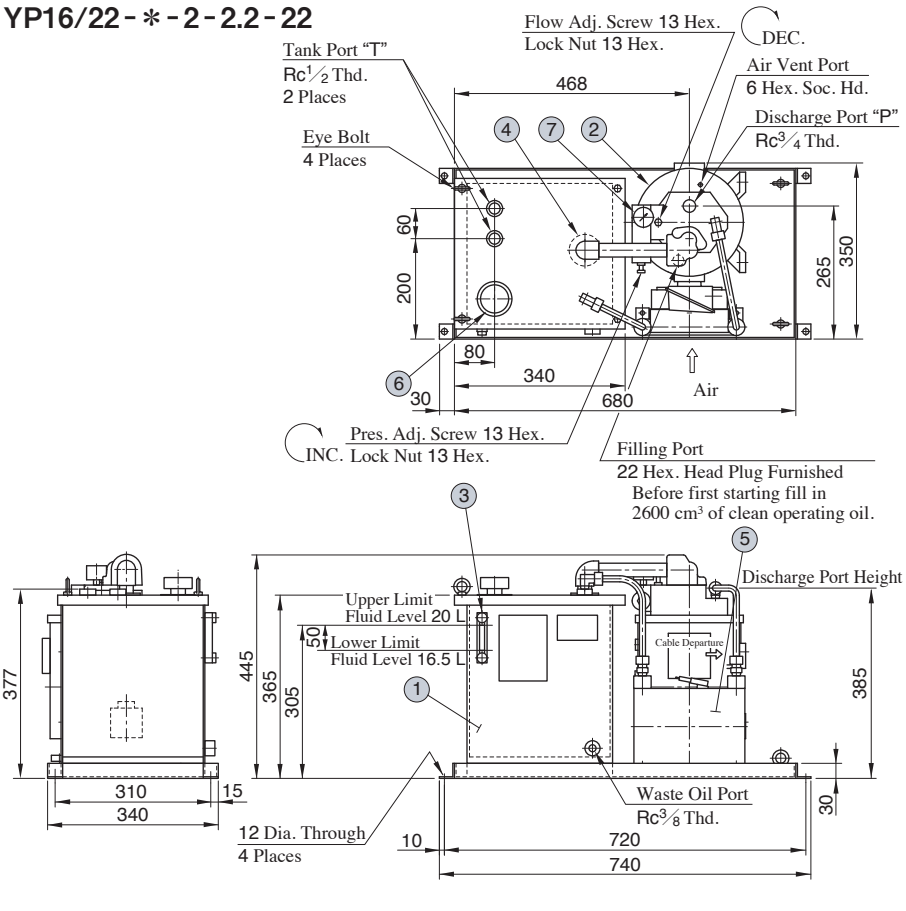

Item	Name
1	Hydraulic Reservoir
2	Pal Pump
3	Oil Level Gauge
4	Suction Strainer
5	Drain Cooler
6	Air Breather with Filling Port
7	Pressure Gauge

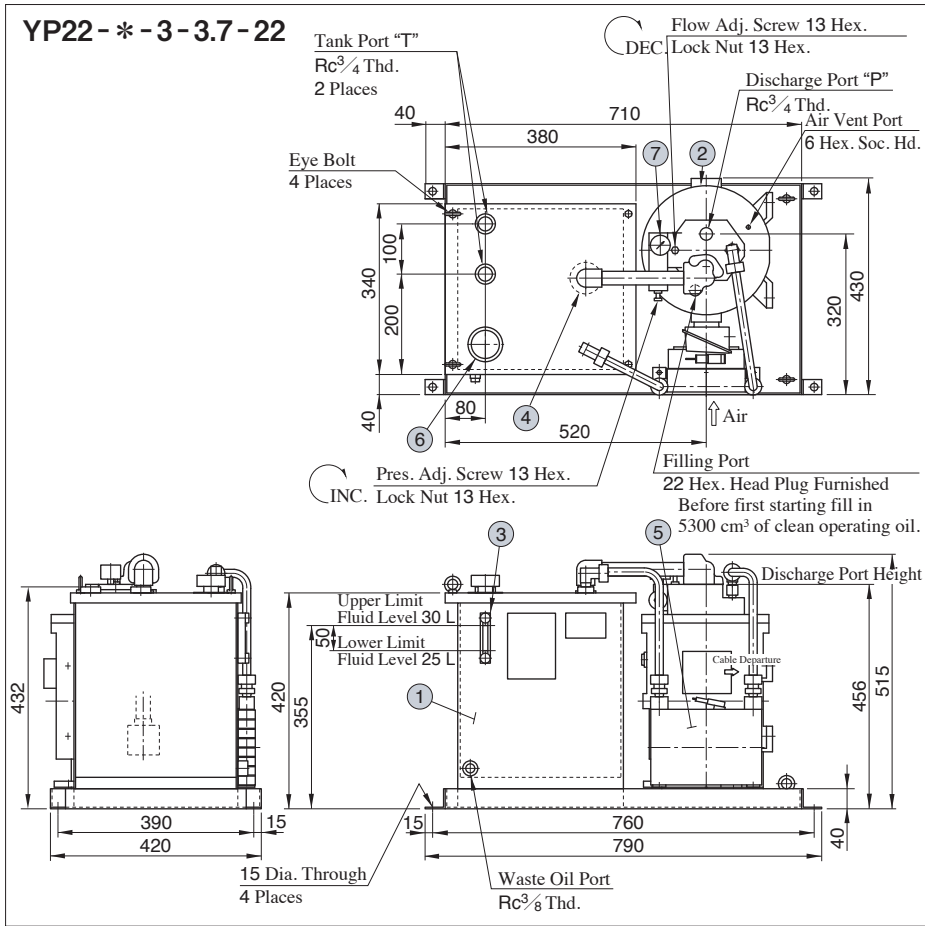

● Hydraulic Circuit

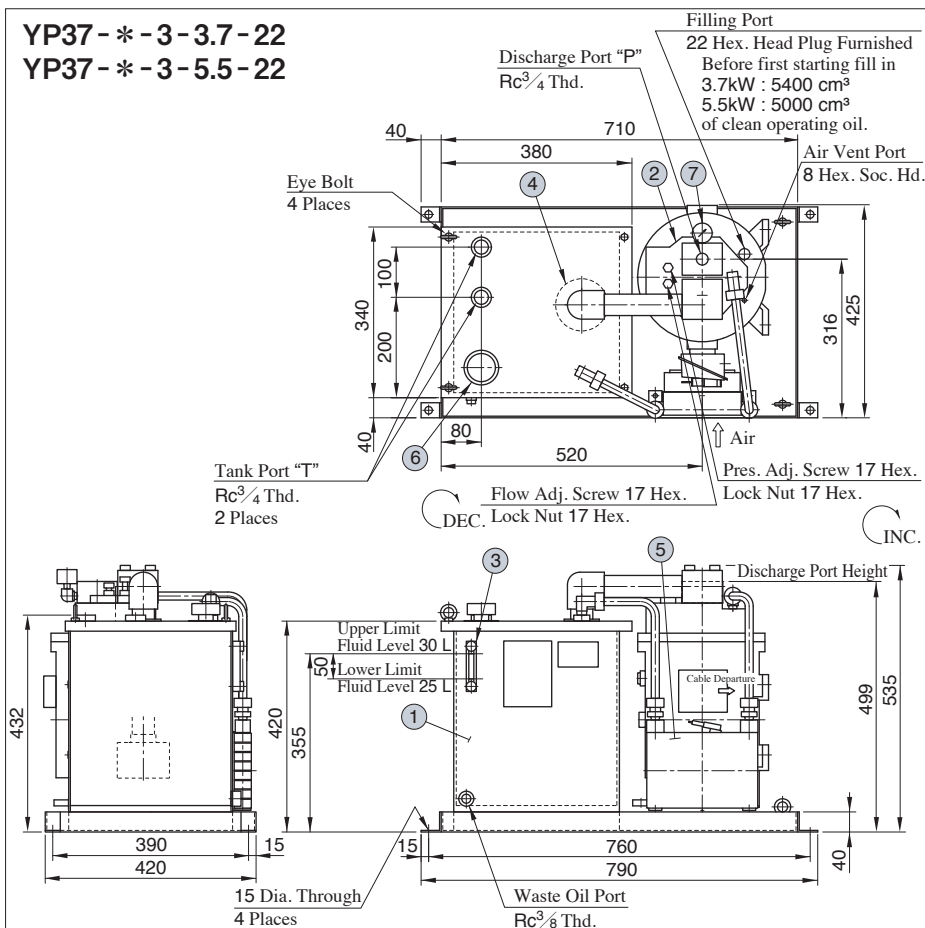
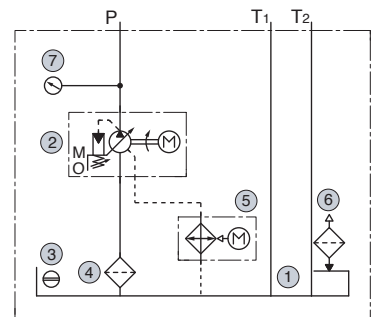

Item	Name
1	Hydraulic Reservoir
2	Pal Pump
3	Oil Level Gauge
4	Suction Strainer
5	Drain Cooler
6	Air Breather with Filling Port
7	Pressure Gauge