

DSG-005 Series Solenoid Operated Directional Valves

These DSG-005 series solenoid directional valves are the products newly developed as a “Mini-series”.

The valves are much more compactly manufactured but enjoy a maximum operating pressure of 25 MPa and a maximum flow rate of 15 L/min, while contributing further to a space saving requirement.

Moreover, using wet armature solenoids, the valves ensure the long life and low noise.

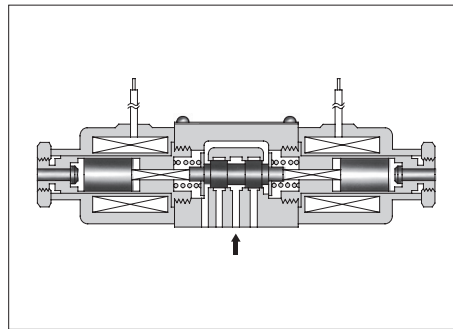

Flying Lead Wire Type

Plug-in Connector Type

Specifications

Model Numbers	Max. Flow* L/min	Max. Operating Pressure MPa	Max. Tank-Line Back Pressure MPa	Max. Changeover Frequency min ⁻¹	Approx. Mass kg
DSG-005-3C * - * -40	15	25	7	120	0.5
DSG-005-2B * - * -40					0.4

★ The maximum flow means the limited flow without inducing any abnormality to the operation (changeover) of the valve.
The maximum flow differs according to the type and operating conditions. For details, please refer to the “List of Standard Models and The Maximum Flow” on page E-12.

Solenoid Ratings

Electric Source	Coil Type	Frequency (Hz)	Voltage (V)		Current & Power at Rated Voltage		
			Source Rating	Serviceable Range	Inrush* ¹ (A)	Holding (A)	Power (W)
AC	A 100	50	100	80 - 110	0.36	0.16	—
		60		90 - 120	0.34	0.11	
	A 200	50	200	160 - 220	0.18	0.08	
		60		180 - 240	0.17	0.05	
DC* ²	D12	—	12	10.8 - 13.2	—	1.2	15
	D24	—	24	21.6 - 26.4		0.6	

★1. Inrush current in the above table shows rms values at maximum stroke.
★2. The Plug-in Connector Type DC solenoid has a built-in surge absorber.
The Flying Lead Wire type has no surge absorber equipped. Install a surge absorber separately.

Model Number Designation

DSG	-005	-3	C	2	-D24	-N	-40
Series Number	Valve Size	Number of Valve Positions	Spool-Spring Arrangement	Spool Type	Coil Type	Electrical Conduit Connection	Design Number
DSG : Solenoid Operated Directional Valve (Sub-plate Mount Type)	005	3	C: Spring Centered	2, 3 40	AC A100 A200 DC D12 D24	None : Flying Lead Wire Type N : Plug-in Connector Type N1: Plug-in Connector with Indicator Light	40
		2	B: Spring Offset	2, 3			

Note: Models for phosphate ester fluid are available. When phosphate ester fluid is used, prefix "F-" to the model number because the special seals (fluororubber) are required to be used.

Sub-plates

Sub-plate Model Numbers	Thread Size Rc	Approx. Mass kg
DSGM-005X-20	1/8	0.8
DSGM-005Y-20	1/4	

- Sub-plates are available. Specify the sub-plate model number from the table above. When sub-plates are not used, the mounting surface should have a good machined finish. ($\frac{1}{16}$)
And the port hole diameter should below 4.3 Dia..

Accessories

Mounting Bolts	Tightening Torque
Soc. Hd. Cap Screw : M4×35L...4Pcs.	2.5 - 3.5 Nm

Electrical Conduit Connection

The solenoid common use 50 & 60 Hz, so no need to change connection by difference of frequency.
The solenoid polarity is irrelevant with connection.

Typical Changeover Time (Example)

Changeover time varies according to oil viscosity, spool type and hydraulic circuit.

[Test Conditions]

Pressure : 16 MPa

Flow Rate : 7.5 L/min

Viscosity : 30 mm²/s

Voltage : Rated Voltage (After coil temperature rise and saturated)

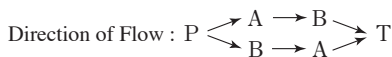

[Result of Measurement]

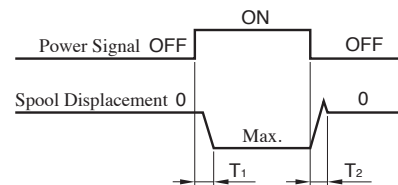

Model Numbers	Time ms	
	T ₁	T ₂
DSG-005-3C2-A *	16	60
DSG-005-3C2-D *	23	40
DSG-005-2B2-A *	14	45
DSG-005-2B2-D *	15	33

List of Standard Models

Models with AC Solenoids : DSG-005- * * * -A *

No. of Valve Positions	Spool-Spring Arrangement	Model Numbers	Graphic Symbols	Max. Flow L/min											
				Working Pressure MPa				Working Pressure MPa				Working Pressure MPa			
				5	10	16	25	5	10	16	25	5	10	16	25
Three Positions	Spring Centered	DSG-005-3C2		15	15	15	15	15 (14)	15 (7)	12 (3)	4 (0.5)	15 (14)	15 (7)	12 (3)	4 (0.5)
		DSG-005-3C3		12	12	12	12	15	15	15	15	15	15	15	15
		DSG-005-3C40		15	15	15	15	15 (14)	15 (6)	12 (2)	4 (0.5)	15 (14)	15 (6)	12 (2)	4 (0.5)
Two Positions	Spring Offset	DSG-005-2B2		14	14	14	14	2	1	1	1	15 (14)	15 (10)	13 (5)	6 (0.5)
		DSG-005-2B3		13.5	13.5	13.5	13.5	3	3	3	3	15	15 (14)	15 (11)	15 (9)

Notes: The relation between the maximum flow in the table above and the frequency/voltage (within the serviceable voltage) is as shown below.

(Example)

The maximum flow rate is constant regardless of 50 Hz or 60 Hz and of any voltage variants within the serviceable voltage

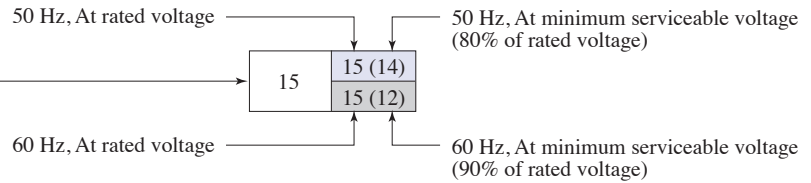

Models with DC Solenoids : DSG-005- * * * -D *

No. of Valve Positions	Spool-Spring Arrangement	Model Numbers	Graphic Symbols	Max. Flow L/min											
				Working Pressure MPa				Working Pressure MPa				Working Pressure MPa			
				5	10	16	25	5	10	16	25	5	10	16	25
Three Positions	Spring Centered	DSG-005-3C2		15	15	15	15	15	8	5	3	15	8	5	3
		DSG-005-3C3		15	15	15	15	15	15	15	15	15	15	15	15
		DSG-005-3C40		15	15	15	15	15	13	8	5	15	13	8	5
Two Positions	Spring Offset	DSG-005-2B2		14	14	14	14	8.5	4.5	6.5	6.5	15	15	11	9
		DSG-005-2B3		13.5	13.5	13.5	13.5	8	7	8	9	15	15	15	13.5

Notes: The relation between the maximum flow in the table above and the voltage (within the serviceable voltage) is as shown below.

(Example)

The maximum flow rate is constant regardless of any voltage variants within the serviceable voltage

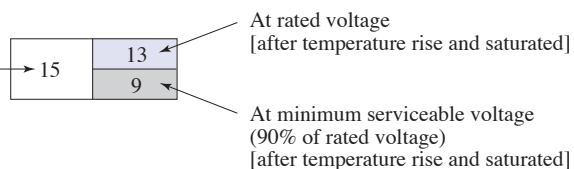

Pressure Drop

Pressure drop curves based on viscosity of 30 mm²/s and specific gravity of 0.850.

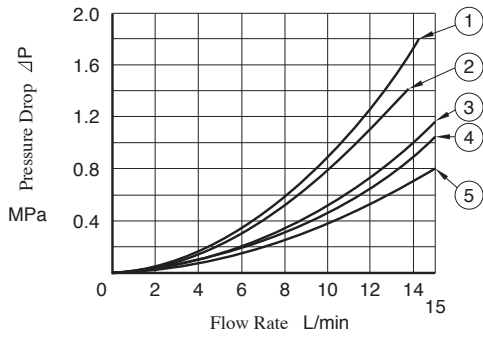

Model Numbers	Pressure Drop Curve Numbers				
	P → A	B → T	P → B	A → T	P → T
DSG-005-3C2	④	④	④	④	—
DSG-005-3C3	⑤	⑤	⑤	⑤	③
DSG-005-3C40	④	④	④	④	—
DSG-005-2B2	①	①	④	④	—
DSG-005-2B3	②	②	④	④	—

● For any other viscosity, multiply the factors in the table below.

Viscosity mm ² /s	15	20	30	40	50	60	70	80	90	100
Factor	0.84	0.91	1.00	1.07	1.14	1.19	1.24	1.28	1.32	1.35

● For any other specific gravity (G'), the pressure drop (ΔP') may be obtained from the formula below.
 $\Delta P' = \Delta P (G'/0.850)$

■ Flying Lead Wire Type

- Spring Centered : **DSG-005-3C* - $\frac{A}{D}$ ***

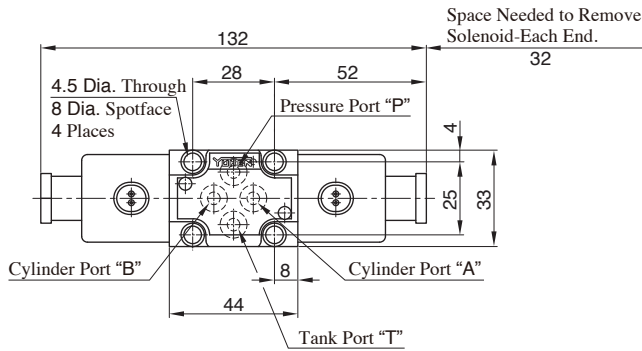

- Spring Offset : **DSG-005-2B* - $\frac{A}{D}$ ***

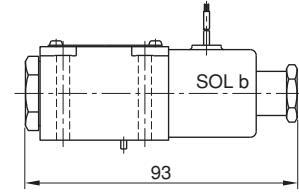

- For other dimensions, refer to "Spring Centered" type.

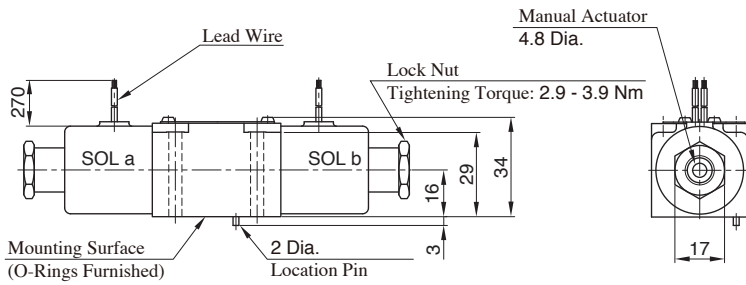

■ DIN Connector Type / DIN Connector with Indicator Light

- Spring Centered : **DSG-005-3C* - $\frac{A}{D}$ * - N/N1**
- Spring Offset : **DSG-005-2B* - $\frac{A}{D}$ * - N/N1**

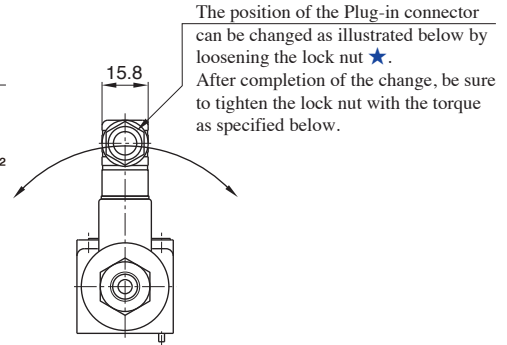
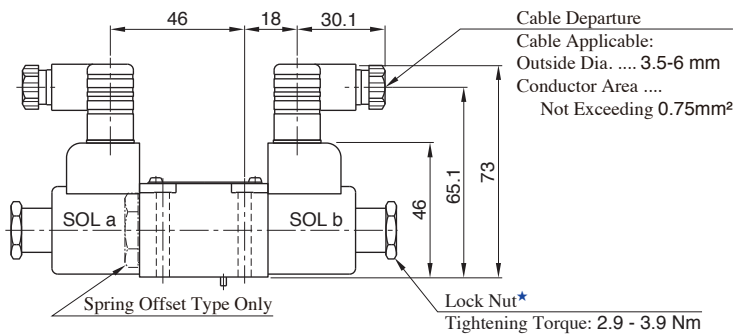

- For other dimensions, refer to "Flying Lead Wire Type".

■ Sub-plate : **DSGM-005X, 005Y**

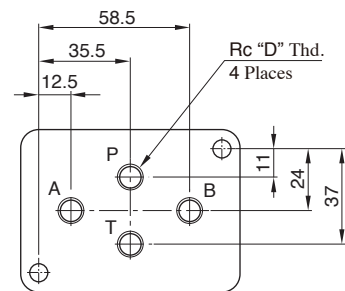
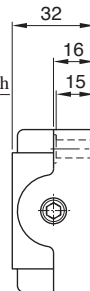
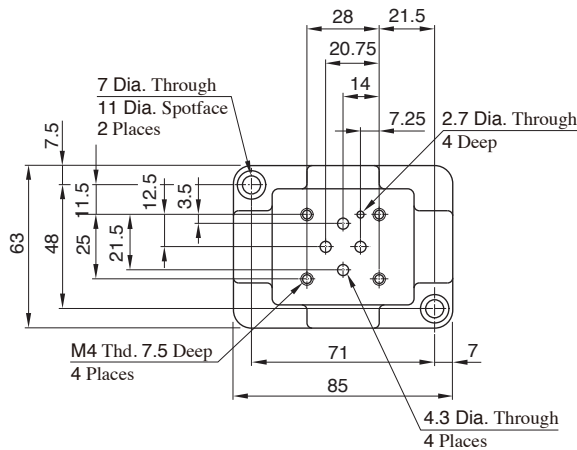

Sub-plate Model Numbers	D	Approx. Mass kg
DSGM-005X-20	1/8	0.8
DSGM-005Y-20	1/4	

List of Seals, Solenoid Ass'y

DSG-005

Spring Offset Type (2B*)

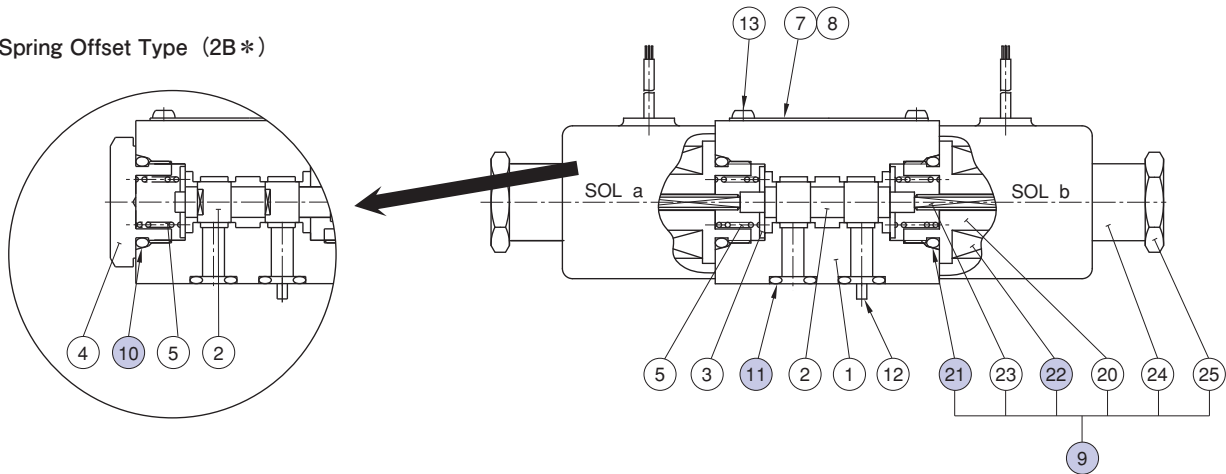

List of Seals

Item	Name of Parts	Part Numbers	Qty.		Remarks
			3C*	2B*	
10	O-Ring	OR NBR-90 P14-N	—	1	
11	O-Ring	OR NBR-90 P6-N	4	4	
21	O-Ring	OR NBR-90 P14-N	2	1	Included in Solenoid Ass'y ⑨

Solenoid Ass'y, Coil Ass'y No.

Valve Model Numbers	⑨ Solenoid Ass'y No.	⑳ Coil Ass'y No.	Remarks
DSG-005-***-A100	SA05-100-40	C-SA05-100-40	Flying Lead Wire Type
DSG-005-***-A200	SA05-200-40	C-SA05-200-40	
DSG-005-***-D12	SD05-12-40	C-SD05-12-40	
DSG-005-***-D24	SD05-24-40	C-SD05-24-40	
DSG-005-***-A100-N/N1	SA05-100-N-40	C-SA05-100-N-40	Plug-in Connector Type /Plug-in Connector with Indicator Light
DSG-005-***-A200-N/N1	SA05-200-N-40	C-SA05-200-N-40	
DSG-005-***-D 12-N/N1	SD05- 12-N-40	C-SD05- 12-N-40	
DSG-005-***-D 24-N/N1	SD05- 24-N-40	C-SD05- 24-N-40	

DSG-007 Series Solenoid Operated Directional Valves

These DSG-007 series solenoid directional valves are the products based on the DSG-005 series and mounting surface dimensions are suit for ISO standard.

The valves are much more compactly manufactured but enjoy a maximum operating pressure of 25 MPa and a maximum flow rate of 15 L/min, while contributing further to a space saving requirement.

Moreover, using wet armature solenoids, the valves ensure the long life and low noise.

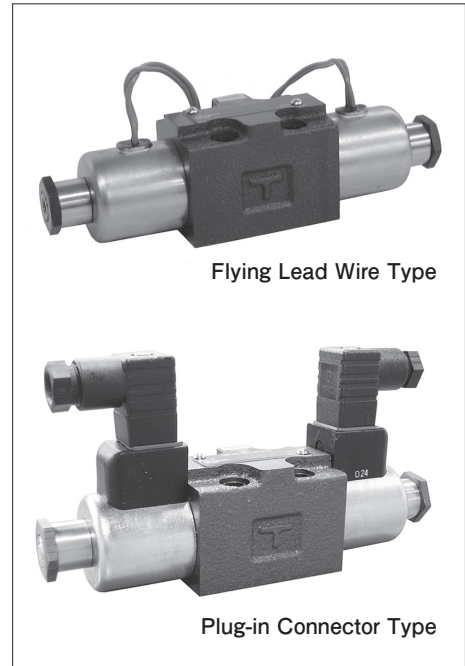
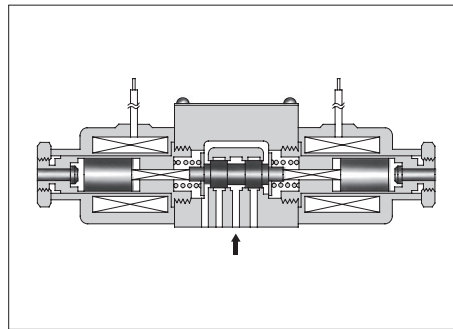

Specifications

Model Numbers	Max. Flow* L/min	Max. Operating Pressure MPa	Max. Tank-Line Back Pressure MPa	Max. Changeover Frequency min ⁻¹	Approx. Mass kg
DSG-007-3C * - * -10	15	25	7	120	0.7
DSG-007-2B * - * -10					0.57

★ The maximum flow means the limited flow without inducing any abnormality to the operation (changeover) of the valve.
The maximum flow differs according to the type and operating conditions. For details, please refer to the “List of Standard Models and Maximum Flow” on pages E-18 to E-19.

Solenoid Ratings

Electric Source	Coil Type	Frequency (Hz)	Voltage (V)		Current & Power at Rated Voltage		
			Source Rating	Serviceable Range	Inrush* ¹ (A)	Holding (A)	Power (W)
AC	A 100	50	100	80 - 110	0.36	0.16	—
		60		90 - 120	0.34	0.11	
	A 200	50	200	160 - 220	0.18	0.08	
		60		180 - 240	0.17	0.05	
DC* ²	D12	—	12	10.8 - 13.2	—	1.2	15
	D24	—	24	21.6 - 26.4		0.6	

★ 1. Inrush current in the above table shows rms values at maximum stroke.
★ 2. The Plug-in Connector Type DC solenoid has a built-in surge absorber.
The Flying Lead Wire type has no surge absorber equipped. Install a surge absorber separately.

Model Number Designation

DSG	-007	-3	C	2	-D24	-N	-10
Series Number	Valve Size	Number of Valve Positions	Spool-Spring Arrangement	Spool Type	Coil Type	Electrical Conduit Connection	Design Number
DSG : Solenoid Operated Directional Valve (Sub-plate Mount Type)	007	3	C : Spring Centered	2, 3 4, 40	AC A100 A200 DC D12 D24	None: Flying Lead Wire Type N: Plug-in Connector Type N1: Plug-in Connector with Indicator Light	10
		2	B : Spring Offset	2, 3, 8			

Note: Models for phosphate ester fluid are available. When phosphate ester fluid is used, prefix "F-" to the model number because the special seals (fluororubber) are required to be used.

Sub-plates

Sub-plate Model Numbers	Thread Size Rc	Approx. Mass kg
DSGM-007X-10	1/8	0.8
DSGM-007Y-10	1/4	

- Sub-plates are available. Specify the sub-plate model number from the table above. When sub-plates are not used, the mounting surface should have a good machined finish. ($\sqrt{6}$)
And the port hole diameter should below 4.3 Dia..

Accessories

Mounting Bolts	Tightening Torque
Soc. Hd. Cap Screw : M5×40L...4Pcs.	5.0 - 7.0 Nm

Electrical Conduit Connection

The solenoid common use 50 & 60 Hz, so no need to change connection by difference of frequency.
The solenoid polarity is irrelevant with connection.

Typical Changeover Time (Example)

Changeover time varies according to oil viscosity, spool type and hydraulic circuit.

[Test Conditions]

Pressure : 16 MPa
Flow Rate : 7.5 L/min
Viscosity : 30 mm²/s
Voltage : Rated Voltage (After coil temperature rise and saturated)

Direction of Flow : P $\begin{matrix} \nearrow A \rightarrow B \\ \searrow B \rightarrow A \end{matrix}$ T

[Result of Measurement]

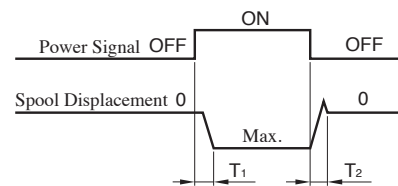

Model Numbers	Time ms	
	T1	T2
DSG-007-3C2-A *	16	60
DSG-007-3C2-D *	23	40
DSG-007-2B2-A *	14	45
DSG-007-2B2-D *	15	33

List of Standard Models

Models with AC Solenoids : DSG-007- * * * - A *

No. of Valve Positions	Spool-Spring Arrangement	Model Numbers	Graphic Symbols	Max. Flow L/min											
								 [Port "B" Blocked]				 [Port "A" Blocked]			
				Working Pressure MPa				Working Pressure MPa				Working Pressure MPa			
				5	10	16	25	5	10	16	25	5	10	16	25
Three Positions	Spring Centered	DSG-007-3C2		15	15	15	15	15(14)	15(7)	12(3)	4(0.5)	15(14)	15(7)	12(3)	4(0.5)
								15(12)	12(3)	5(1)	1(0.5)	15(12)	12(3)	5(1)	1(0.5)
		DSG-007-3C3		12	12	12	12	15	15	15	15	15	15	15	15
				DSG-007-3C4		13	13	13(6)	8(2)	15(14)	15(6)	12(2)	4(0.5)	15(14)	15(6)
9(4)	4(1)	15(10)	12(5)			5(2)	1(0.5)	15(10)	12(5)	5(2)	1(0.5)				
DSG-007-3C40		15	15	15	15	15(14)	15(6)	12(2)	4(0.5)	15(14)	15(6)	12(2)	4(0.5)		
						15(10)	12(5)	5(2)	1(0.5)	15(10)	12(5)	5(2)	1(0.5)		
Two Positions	Spring Offset	DSG-007-2B2		14	14	14	14	2	1	1	1	15(14)	15(10)	13(5)	6(0.5)
												15(14)	14(9)	8(4)	4(0.5)
		DSG-007-2B3		13.5	13.5	13.5	13.5	3	3	3	3	15	15(14)	15(11)	15(9)
										15(14)	15(11)	15(9)			
DSG-007-2B8		—	—	—	—	3	1	1	0.5	15(5)	14(1)	6(0.5)	2(0.5)		
										14(5)	3(1)	1(0.5)	1(0.5)		

Notes: The table above based on viscosity of 30mm²/s.



The relation between the maximum flow and the voltage (within the serviceable voltage) is as shown below.

(Example)

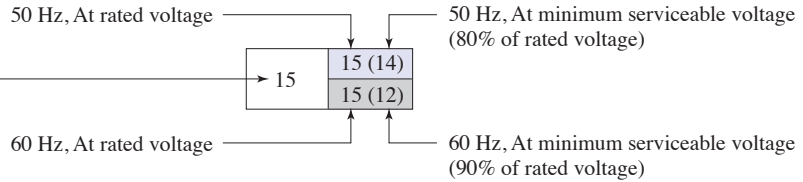
The maximum flow rate is constant regardless of any voltage variants.

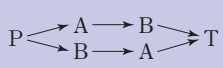
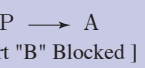
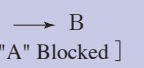
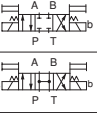
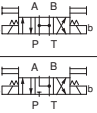
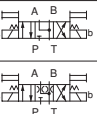
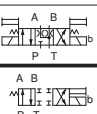
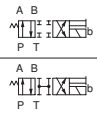

● Models with DC Solenoids : DSG-007-***-D*

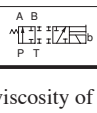
No. of Valve Positions	Spool-Spring Arrangement	Model Numbers	Graphic Symbols	Max. Flow L/min											
															
				Working Pressure MPa				Working Pressure MPa				Working Pressure MPa			
				5	10	16	25	5	10	16	25	5	10	16	25
Three Positions	Spring Centered	DSG-007-3C2		15	15	15	15	15	8	5	3	15	8	5	3
		DSG-007-3C3		15	15	15	15	15	15	15	15	15	15	15	15
		DSG-007-3C4		15	15	8.5	4.5	15	9.5	5.5	3.5	15	9.5	5.5	3.5
		DSG-007-3C40		15	15	15	15	15	13	8	5	15	13	8	5
Two Positions	Spring Offset	DSG-007-2B2		14	14	14	14	8.5	4.5	6.5	6.5	15	15	11	9
		DSG-007-2B3		13.5	13.5	13.5	13.5	8	7	8	9	15	15	15	13.5
		DSG-007-2B8		—	—	—	—	15	3.5	2	1.5	15	4	2.5	2

Notes: The table above based on viscosity of 30mm²/s.

The relation between the maximum flow and the voltage (within the serviceable voltage) is as shown below.

(Example)

The maximum flow rate is constant regardless of any voltage variants

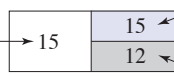

At rated voltage [after temperature rise and saturated]

At minimum serviceable voltage (90% of rated voltage) [after temperature rise and saturated]

Pressure Drop

Pressure drop curves based on viscosity of 30 mm²/s and specific gravity of 0.850.

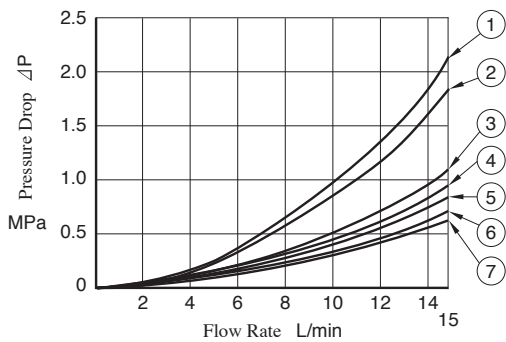

Model Numbers	Pressure Drop Curve Numbers				
	P→A	B→T	P→B	A→T	P→T
DSG-007-3C2	⑤	⑤	⑤	⑤	—
DSG-007-3C3	⑥	⑥	⑥	⑥	③
DSG-007-3C4	⑤	⑦	⑤	⑦	—
DSG-007-3C40	⑤	⑤	⑤	⑤	—
DSG-007-2B2	①	①	④	④	—
DSG-007-2B3	②	②	⑤	⑥	—
DSG-007-2B8	⑤	—	④	—	—

● For any other viscosity, multiply the factors in the table below.

Viscosity mm ² /s	15	20	30	40	50	60	70	80	90	100
Factor	0.84	0.91	1.00	1.07	1.14	1.19	1.24	1.28	1.32	1.35

● For any other specific gravity (G'), the pressure drop (ΔP) may be obtained from the formula below.

$$\Delta P' = \Delta P (G'/0.850)$$

■ Flying Lead Wire Type

- Spring Centered : **DSG-007-3C*** - $\frac{A}{D}$ *

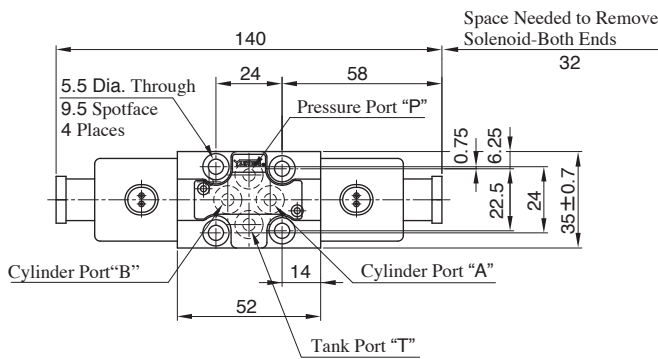

- Spring Offset :

- DSG-007-2B*** - $\frac{A}{D}$ *

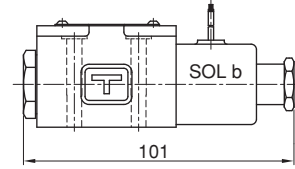

- For other dimensions, refer to "Spring Centered" type.

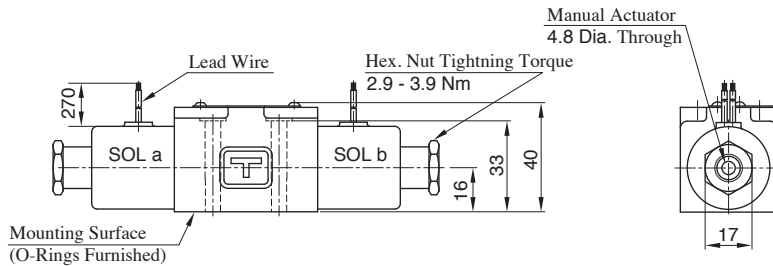

■ DIN Connector Type / DIN Connector with Indicator Light

- Spring Centered : **DSG-007-3C*** - $\frac{A}{D}$ * - N/N1

- Spring Offset : **DSG-007-2B*** - $\frac{A}{D}$ * - N/N1

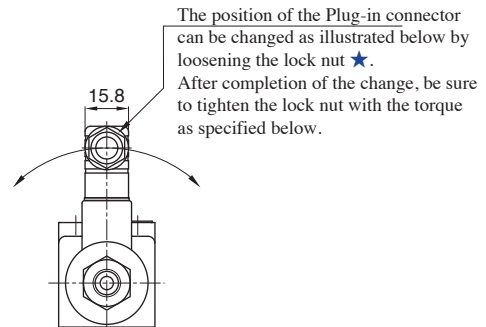
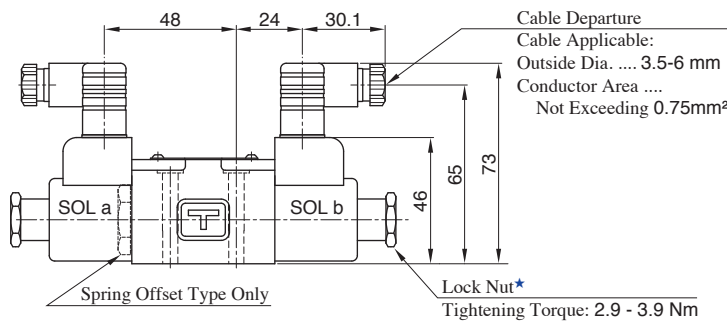

- For other dimensions, refer to "Flying Lead Wire Type".

■ Sub-plate : **DSGM-007X, 007Y**

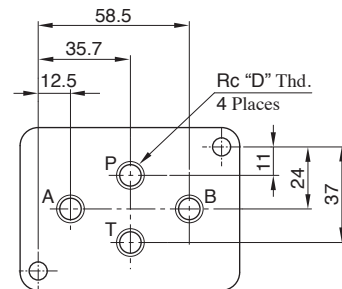
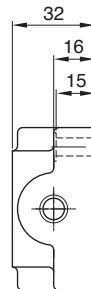
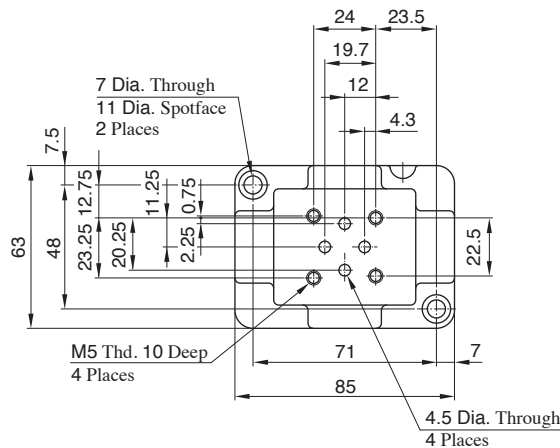

Sub-plate Model Numbers	D	Approx. Mass kg
DSGM-007X-10	1/8	0.8
DSGM-007Y-10	1/4	

List of Seals, Solenoid Ass'y

DSG-007

Spring Offset Type (2B*)

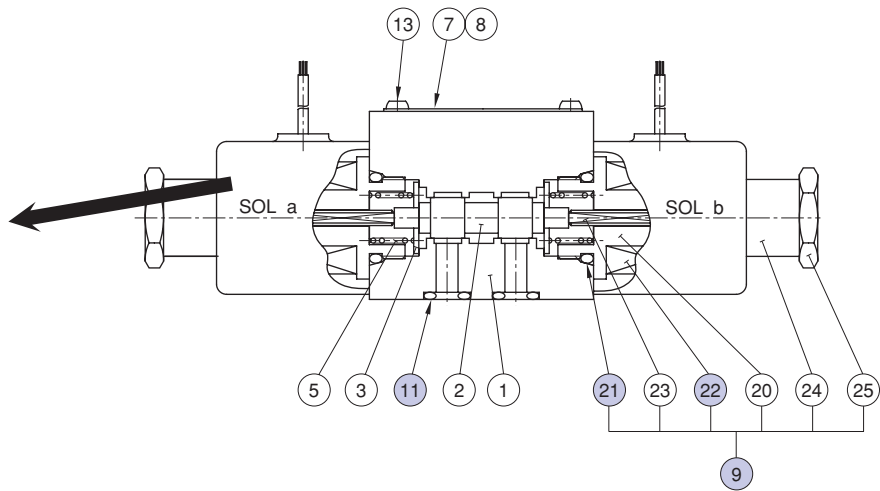
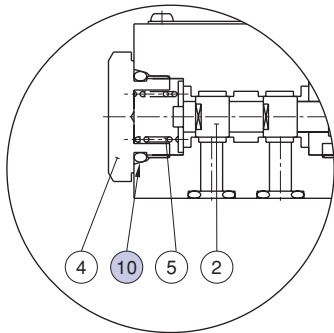

List of Seals

Item	Name of Parts	Part Numbers	Qty.		Remarks
			3C*	2B*	
10	O-Ring	OR NBR-90 P14-N	—	1	
11	O-Ring	OR NBR-90 P7-N	4	4	
21	O-Ring	OR NBR-90 P14-N	2	1	Included in Solenoid Ass'y ⑨

Solenoid Ass'y, Coil Ass'y No.

Valve Model Numbers	⑨Solenoid Ass'y No.	⑫Coil Ass'y No.	Remarks
DSG-007-***-A100	SA05-100-40	C-SA05-100-40	Flying Lead Wire Type
DSG-007-***-A200	SA05-200-40	C-SA05-200-40	
DSG-007-***-D12	SD05-12-40	C-SD05-12-40	
DSG-007-***-D24	SD05-24-40	C-SD05-24-40	
DSG-007-***-A100-N/N1	SA05-100-N-40	C-SA05-100-N-40	Plug-in Connector Type / Plug-in Connector with Indicator Light
DSG-007-***-A200-N/N1	SA05-200-N-40	C-SA05-200-N-40	
DSG-007-***-D 12-N/N1	SD05- 12-N-40	C-SD05- 12-N-40	
DSG-007-***-D 24-N/N1	SD05- 24-N-40	C-SD05- 24-N-40	