

## Solenoid Controlled Pilot Operated Directional Valves

### ● High Pressure / High Flow

Size “04” valves can flow maximum 300 L/min, “06” valves can flow maximum 500 L/min and “10” valves can flow maximum 1100 L/min. High pressure along with high flow means compact system design.

### ● Lower Pressure Drop

System energy saving increased as pressure drop of each valve has been greatly reduced.

### ● Easy Exchange Between Pilot and Drain Connection Type

It is easy to exchange between pilot and drain connection type (internal ↔ external) by plug mounting on-off.

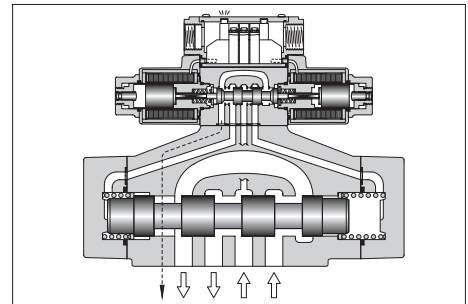
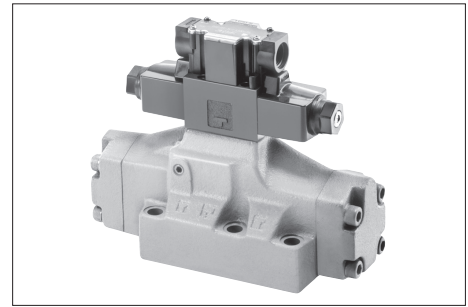

### ■ Specifications

Valve Type	Model Numbers	Max. Flow L/min	Max. Operating Pressure MPa	Max. Pilot Pressure MPa	Min. Required Pilot Pres. MPa	Max. T-Line Back Pressure MPa		Max. Changeover Frequency min <sup>-1</sup>			Mass kg	
						Ext. Drain	Int. Drain	AC	DC	R		
Standard Type	DSHG-01-3C * - * -14	40	21	21	1.0	16	16	120	120	120	4.0 (3.2) <sup>★4</sup>	
	DSHG-01-2B * - * -14										3.5 (2.7) <sup>★4</sup>	
	DSHG-03-3C * - * -14	160	25	25	0.7	16	16	120	120	120	6.9	
	DSHG-03-2N * - * -14										6.9	
	DSHG-03-2B * - * -14										6.4	
Shockless Type	(S-) DSHG-04-3C * - * -52	300	31.5	25	0.8	21	21	120	120	120	8.5	
	(S-) DSHG-04-2N * - * -52										8.5	
	(S-) DSHG-04-2B * - * -52										8.0	
	(S-) DSHG-06-3C * - * -53	500	31.5	25	0.8 <sup>★3</sup>	21	21	120	120	120	12.4	
	(S-) DSHG-06-2N * - * -53										12.4	
	(S-) DSHG-06-2B * - * -53			11.9								
	(S-) DSHG-06-3H * - * -53			13.2								
	(S-) DSHG-10-3C * - * -43	1100	31.5	25	1.0 <sup>★3</sup>	21	21	120	120	100	45.0	
	(S-) DSHG-10-2N * - * -43			1.0							100	100
(S-) DSHG-10-2B * - * -43	21			60	60						50	44.5
(S-) DSHG-10-3H * - * -43	21			60	60						50	52.9

★1. Maximum flow indicates a ceiling flow, refer to the List of Standard Models on pages E-74 - E-78 for details.

★2. Pilot pressure of internal pilot drain models must always exceed tank line back pressure by a minimum required pilot pressure.

★3. Min. pilot pressure of with pilot piston is 1.8 MPa.

★4. Only the mass of internal pilot and internal drain type valve is the value in parentheses.

● Please contact us about High Flow Valves (Flange Connecting Type).

### ■ Solenoid Ratings

Refer to relevant solenoid ratings described on the page below.

Model Numbers	Pilot Valve Model Numbers	Solenoid Ratings described on the page below
DSHG-01	DSG-01- * * * - * -70	E-23
DSHG-03		
(S-) DSHG-04		
(S-) DSHG-06		
(S-) DSHG-10		

Solenoid Controlled Pilot Operated Type

### Model Number Designation

S-	DSHG	-06	-2	B	2	A	-C2	-E	T	
Type	Series Number	Valve Size	No. of Valve Positions	Spool-Spring Arrangement	Spool Type	Input Only Valves Using Neutral Position & Side Position	Models with Pilot Choke Valve	Pilot Connection	Drain Connection	
None: Standard Type	DSHG :	01	3	C : Spring Centered	2, 3, 4 40, 5, 60 7, 9, 10 11, 12	—	—	None: Internal Pilot	None: External Drain	
			2	B : Spring Offset	2, 3, 4 40, 7	—				
		03	3	C : Spring Centered	2, 3, 4 40, 5, 60 7, 9, 10 11, 12	—	C1 : With C1 Choke			
			2	N : No-Spring	2 3 4 40 7	—				
None: Standard Type	Solenoid Controlled Pilot Operated Directional Valve, Sub-plate Mounting	04	3	C : Spring Centered	2, 4, 40 60, 10, 12 (3, 5, 6) <sup>*1</sup> (7, 9, 11)	—		C2 : With C2 Choke	E : External Pilot	T : Internal Drain
			2	N : No-Spring	2, 4, 40 (3, 7) <sup>*1</sup>	A <sup>*2</sup>				
		06	3	C : Spring Centered	2, 4, 40 60, 10, 12 (3, 5, 6) <sup>*1</sup> (7, 9, 11)	—	C1C2 : With C1 & C2 Choke			
			H : Pressure Centered <sup>*3</sup>	2, 4, 40 (3, 7) <sup>*1</sup>	A <sup>*2</sup>					
10	2	N : No-Spring	2, 4, 40 (3, 7) <sup>*1</sup>	A <sup>*2</sup>						
	B : Spring Offset	2, 4, 40 (3, 7) <sup>*1</sup>	A <sup>*2</sup> B <sup>*2</sup>							

Note: In spool type “3”, “5”, “6”, “60”, and “7”, the combination applicable between pilot system and drain system is as described in the table below.

Pilot Connection	Drain Connection	Care in Application
Internal Pilot	External Drain	Hold back pressure in the tank line so that the difference between pilot pressure and drain pressure is always more than minimum required pilot pressure.
	Internal Drain (T)	Combination is not applicable.
External Pilot (E)	External Drain	No restrictions in the combination on us
	Internal Drain (T)	

#### Attention

In the table above, the symbols and numbers highlighted with shade represent the optional extras. The valves with model number having such optional extras are handled as options, therefore please confirm the time of delivery with us before ordering.

	-R2	-A100	-C	-H	-N	-53	-L
	Spool Control Modification (Omit if not required)	Coil Type	Manual Override of Pilot Valve	Built-in Orifice for Pilot Line	Type of Electrical Conduit Connection	Design Number	Models with Reverse Mtg. of Solenoid
	_____	AC: A100 , A200 A120 , A240		_____		14	_____
		DC: D12 , D24 D48		_____	None: Terminal Box Type	14	_____
	R2 : With Stroke Adjustment, Both Ends RA : With Stroke Adjustment, Port "A" End RB : With Stroke Adjustment, Port "B" End	AC → DC : R100 , R200	None : Manual Override Pin	_____	N : Plug-in Connector Type	52	_____
		AC: A100 , A200 A120 , A240	C : Push Button & Lock Nut	_____	N1 : Plug-in*4 Connector with Indicator Light	53	_____
	R2 : With Stroke Adjustment, Both Ends RA : With Stroke Adjustment, Port "A" End RB : With Stroke Adjustment, Port "B" End P2 : With Pilot Piston, Both Ends PA : With Pilot Piston, Port "A" End PB : With Pilot Piston, Port "B" End	DC: D12 , D24 D48		H : *5 Input only for spool-spring arrangement "H" and with built-in orifice.		43	_____
		AC → DC : R100 , R200					L : Input only for reverse mtg. of solenoid.

- ★1. Shockless type (S-DSHG) are not available for spool type marked ( ).
- ★2. As for the details of the valve using the neutral position and the side position, please refer to page E-79. Furthermore, the spool types other than "2", "4", "40" (3, 7) are also available.
- ★3. In spool-spring arrangement "H" (Pressure centered models), the valves with stroke adjustment (R\*) and pilot-piston (P\*) are not available.
- ★4. N1 stands for Plug-in connector with solenoid indicator light. N1 is not available for R-type solenoids.
- ★5. In spool-spring arrangement "H" (pressure centered models), in case the pilot pressure is more than 10 MPa, please specify that the valve should have the built-in orifice to the pilot line.
- ★6. Models for phosphate ester fluid are available. When phosphate ester fluid is used, prefix "F-" to the model number because the special seals (fluororubber) are required to be used.

### CSA Approved Solenoid Valve

Available to supply DSHG-06 series valve approved by the CSA (Canadian Standards Association). Consult us for details.



## Sub-plates

Valve Model Numbers	Sub-plate Model Numbers	Thread Size Rc	Approx. Mass kg	Figure for the dimensions described on the page below	Remarks
DSHG-01	DSGM-01-31	1/8	0.8	E-31	Common to those for DSG-01 Solenoid Operated Directional Valves
	DSGM-01X-31	1/4			
	DSGM-01Y-31	3/8			
DSHG-03	DSGM-03-40	3/8	3	E-47	As for Internal Pilot - Internal Drain Type, common to those for DSG-03 Solenoid Operated Directional Valves
	DSGM-03X-40	1/2			
	DSGM-03Y-40	3/4	4.7	E-84	For External Pilot Type or External Drain Type
	DHGM-03Y-10	3/4	4.7		
(S-) DSHG-04	DHGM-04-20	1/2	4.4	E-85	_____
	DHGM-04X-20	3/4	4.1		
(S-) DSHG-06	DHGM-06-50	3/4	7.4	E-87	_____
	DHGM-06X-50	1			
(S-) DSHG-10	DHGM-10-40	1 1/4	21.5	E-87	_____
	DHGM-10X-40	1 1/2			

- Sub-plates are available. Specify the sub-plate model number from the table above.  
When sub-plates are not used, the mounting surface should have a good machined finish. (  $\sqrt{16}$  )

## Accessories

### Mounting Bolt

Model Numbers	Mounting Bolt	Qty.	Tightening Torque Nm
DSHG-01	Bolt Kits : MBK-01-01-30 <sup>★1</sup> MBK-01-02-30 <sup>★2</sup>	1set	5 - 6
DSHG-03	Socket Head Cap Bolt : M6×35L	4	12 - 15
(S-) DSHG-04	Socket Head Cap Bolt : M6×45L	2	12 - 15
	Socket Head Cap Bolt : M10×50L	4	58 - 72
(S-) DSHG-06	Socket Head Cap Bolt : M12×60L	6	100 - 123
(S-) DSHG-10	Socket Head Cap Bolt : M20×75L	6	473 - 585

★1. For Internal Pilot-Internal Drain.

★2. For External Pilot-External Drain, External Pilot-Internal Drain and Internal Pilot-External Drain.

### ● Bolt Kits Details

● Stud Bolt ..... 4 Pcs.

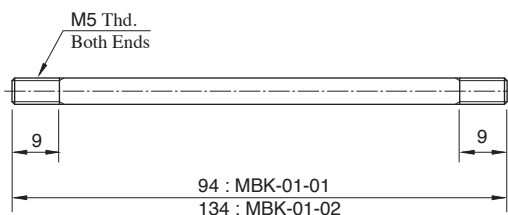

● Nut ..... 4 Pcs.

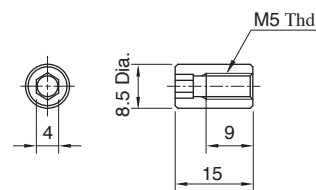

## Options

### Models with Pilot Choke Adjustment (C1, C2, C1C2)

When the adjustment screw is turned clockwise, changeover speed of the main spool becomes slow. In case of the spring centered valves in particular, making slow of the returning speed of the main spool to the neutral position is possible with a C2 choke valve. These choke valves can be used in combination with the valves of spring centered, no-spring, offset, pressure centered and the valves with stroke adjustment.

#### Graphic Symbols (Ex.: Spring Centered) DSHG-01, 06, 10

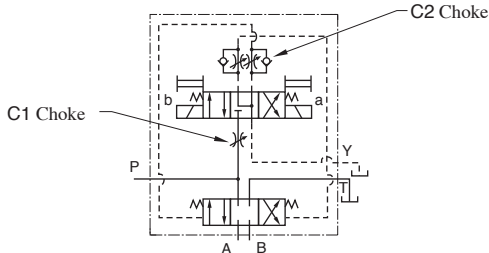

DSHG-03, 04

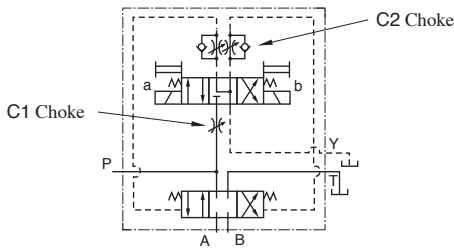

### Models with Pilot Piston (P2, PA, PB)

The valves with a pilot piston can be used when the high speed changeover of the main spool is required. However, in case of spring centered valves, there is no change in the returning speed of the main spool to the neutral position even with the pilot piston.

#### Graphic Symbols (Ex.: Spring Centered)

##### "P2" Models

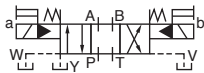

##### "PA" Models

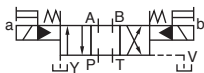

##### "PB" Models

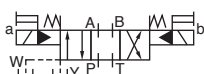

### Pressure Centered Models (3H\*)

The pressure centered type can be used when the returning of the main spool to the neutral position is required to be firmly.

#### Graphic Symbols (Ex.: External Pilot-External Drain)

(Only for 3H6, 3H60)



### Models with Stroke Adjustment (R2, RA, RB)

When the adjustment screw is screwed in, the main spool stroke becomes short and flow rate reduces.

#### Graphic Symbols (Ex.: Spring Centered)

##### "R2" Models

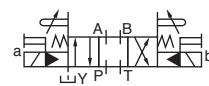

##### "RA" Models

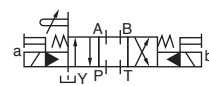

##### "RB" Models

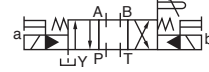

### Additional Mass of Options

Add the mass described below to the mass of standard models on page E-69, if options are required.

(kg)

Model Numbers	Models with Pilot Choke Adj.		Models with Pilot Piston		Models with Stroke Adj.	
	C1, C2	C1C2	P2	PA PB	R2	RA RB
DSHG-03	0.65	1.3	—	—	0.6	0.3
(S-) DSHG-04	0.65	1.3	—	—	1.0	0.5
(S-) DSHG-06	0.65	1.3	1.0	0.5	1.2	0.6
(S-) DSHG-10	0.65	1.3	3.6	1.8	3.7	1.85

### Options on Pilot Valve

The same options to DSG-01 series valves are available. Please refer to page E-23 for the details.

■ List of Standard Models (DSHG-01)

● Three Positions

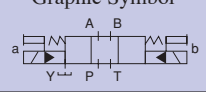
Spool Type	Spring Centered				
		Maximum Flow L/min			
		7 MPa	14 MPa	21 MPa	
Model Numbers					
“2”		DSHG-01-3C2	40	40	40
“3”		DSHG-01-3C3	40	40	40
“4”		DSHG-01-3C4	40	40	40
“40”		DSHG-01-3C40	40	40	40
“5”		DSHG-01-3C5	40	40	40
“60”		DSHG-01-3C60	40	40	40
“7”		DSHG-01-3C7	40	40	40
“9”		DSHG-01-3C9	40	40	40
“10”		DSHG-01-3C10	40	40	40
“11”		DSHG-01-3C11	40	40	40
“12”		DSHG-01-3C12	40	40	40

● Two Positions

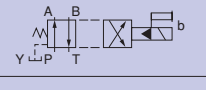
Spool Type	Spring Offset				
		Maximum Flow L/min			
		7 MPa	14 MPa	21 MPa	
Model Numbers					
“2”		DSHG-01-2B2	40	40	40
“3”		DSHG-01-2B3	40	40	40
“4”		DSHG-01-2B4	40	40	40
“40”		DSHG-01-2B40	40	40	40
“7”		DSHG-01-2B7	40	40	40

- Notes) 1. Max. flow shows value at pilot pressure more than 1 MPa.  
 2. Max. flow in the table above represents the value in the flow condition of P → A → B → T (or P → B → A → T) as shown in the circuit diagram below.  
 In case the valve is used in the condition that either A or B port is blocked, the maximum flow differs according to a hydraulic circuit, therefore, please consult us for details.

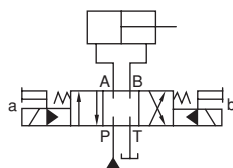

## List of Standard Models (DSHG-03)

### ● Three Positions

Spool Type	Spring Centered				
	Graphic Symbol 	Maximum Flow L/min			
		7 MPa	14 MPa	25 MPa	
Model Numbers					
"2"		DSHG-03-3C2	160	85	60
				160	95
"3"		DSHG-03-3C3	160	160	160
"4"		DSHG-03-3C4	160	85	60
				160	95
"40"		DSHG-03-3C40	160	85	60
				160	95
"5"		DSHG-03-3C5	160	85	60
				160	95
"60"		DSHG-03-3C60	160	160	125
					160
"7"		DSHG-03-3C7	160	85	60
				160	95
"9"		DSHG-03-3C9	160	85	60
				160	95
"10"		DSHG-03-3C10	160	85	60
				160	95
"11"		DSHG-03-3C11	160	85	60
				160	95
"12"		DSHG-03-3C12	160	85	60
				160	95

### ● Two Positions

Spool Type	No-Spring				Spring Offset				
	Graphic Symbol 	Maximum Flow L/min			Graphic Symbol 	Maximum Flow L/min			
		7 MPa	14 MPa	25 MPa		7 MPa	14 MPa	25 MPa	
Model Numbers				Model Numbers					
"2"		DSHG-03-2N2	160	160	85	DSHG-03-2B2	160	160	85
					160			160	
"3"		DSHG-03-2N3	160	160	85	DSHG-03-2B3	160	160	85
					160			160	
"4"		DSHG-03-2N4	160	160	85	DSHG-03-2B4	160	160	85
					160			160	
"40"		DSHG-03-2N40	160	160	85	DSHG-03-2B40	160	160	85
					160			160	
"7"		DSHG-03-2N7	160	160	85	DSHG-03-2B7	160	160	85
					160			160	

Notes: 1. The relation between max. flow and pilot pressure in the table above is as shown below.

#### (Example)

Maximum flow rate is constant regardless of pilot pressure. Pilot Pressure more than 0.7 MPa.

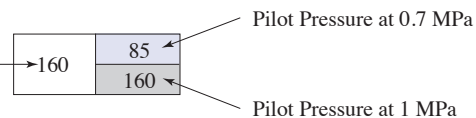





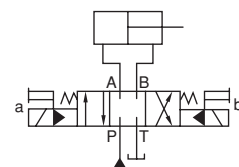





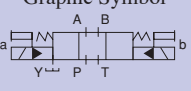

2. Max. flow in the table above represents the value in the flow condition of P → A → B → T (or P → B → A → T) as shown in the circuit diagram right.

In case the valve is used in the condition that either A or B port is blocked, the maximum flow differs according to a hydraulic circuit, therefore, please consult us for details.







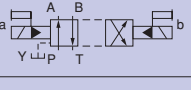
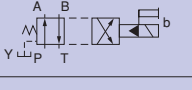

■ List of Standard Models (DSHG-04/S-DSHG-04)

● Three Positions

Spool Type	Spring Centered				
	Graphic Symbol 	Maximum Flow L/min			
		10 MPa	16 MPa	25 MPa	31.5 MPa
Model Numbers					
“2” 	DSHG-04-3C2	300	300	200	145
	S-DSHG-04-3C2	300	250	120	110
“3” 	DSHG-04-3C3	300	300	300	300
“4” 	DSHG-04-3C4	300	300	250	165
	S-DSHG-04-3C4	300	300	140	110
“40” 	DSHG-04-3C40	300	300	200	145
	S-DSHG-04-3C40	300	250	120	110
“5” 	DSHG-04-3C5	255	250	245	235
“6” 	DSHG-04-3C6	300	260	245	235
“60” 	DSHG-04-3C60	300	300	300	300
	S-DSHG-04-3C60	300	300	300	300
“7” 	DSHG-04-3C7	300	300	200	145
“9” 	DSHG-04-3C9	300	300	280	250
“10” 	DSHG-04-3C10	300	300	200	150
	S-DSHG-04-3C10	300	250	120	110
“11” 	DSHG-04-3C11	300	260	160	140
“12” 	DSHG-04-3C12	300	280	170	135
	S-DSHG-04-3C12	300	250	120	110

● Two Positions

Spool Type	No-Spring					Spring Offset				
	Graphic Symbol 	Maximum Flow L/min				Graphic Symbol 	Maximum Flow L/min			
		10 MPa	16 MPa	25 MPa	31.5 MPa		10 MPa	16 MPa	25 MPa	31.5 MPa
Model Numbers					Model Numbers					
“2” 	(S-)DSHG-04-2N2	300	300	300	300	(S-)DSHG-04-2B2	300	300	300	300
“3” 	DSHG-04-2N3	300	300	300	300	DSHG-04-2B3	300	300	300	300
“4” 	(S-)DSHG-04-2N4	300	300	300	300	(S-)DSHG-04-2B4	300	300	300	300
“40” 	(S-)DSHG-04-2N40	300	300	300	300	(S-)DSHG-04-2B40	300	300	300	300
“7” 	DSHG-04-2N7	300	300	300	300	DSHG-04-2B7	300	300	300	300

Notes: 1. Max. flow described above shows value at pilot pressure more than 0.8 MPa.

2. Max. flow in the table above represents the value in the flow condition of P → A → B → T (or P → B → A → T) as shown in the circuit diagram below.



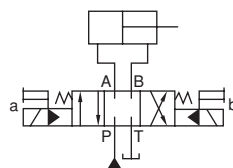







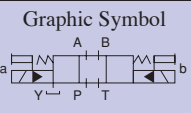
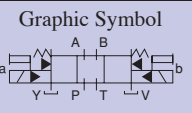

In case the valve is used in the condition that either A or B port is blocked, the maximum flow differs according to a hydraulic circuit, therefore, please consult us for details.









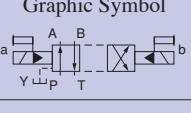
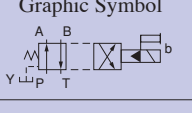

## List of Standard Models (DSHG-06/S-DSHG-06)

### ● Three Positions

Spool Type	Spring Centered					Pressure Centered				
	Graphic Symbol 	Maximum Flow L/min				Graphic Symbol 	Maximum Flow L/min			
		10 MPa	16 MPa	25 MPa	31.5 MPa		10 MPa	16 MPa	25 MPa	31.5 MPa
Model Numbers					Model Numbers					
"2" 	(S-) DSHG-06-3C2	500	500	410 500	310 410	(S-) DSHG-06-3H2	500	500	500	420 500
"3" 	DSHG-06-3C3	500	500	460	370	DSHG-06-3H3	500	500	500	500
"4" 	(S-) DSHG-06-3C4	500	500	410 500	310 500	(S-) DSHG-06-3H4	500	500	500	420 500
"40" 	(S-) DSHG-06-3C40	500	500	410 500	310 500	(S-) DSHG-06-3H40	500	500	500	420 500
"5" 	DSHG-06-3C5	500	500	425	350	DSHG-06-3H5	500	500	500	470 500
"6" 	DSHG-06-3C6	475	390	300	230	DSHG-06-3H6	500	500	500	420 500
"60" 	(S-) DSHG-06-3C60	475	420	340	280	(S-) DSHG-06-3H60	500	500	500	420 500
"7" 	DSHG-06-3C7	500	500	450	360	DSHG-06-3H7	500	500	500	500
"9" 	DSHG-06-3C9	500	500	450 500	360 500	DSHG-06-3H9	500	500	500	500
"10" 	(S-) DSHG-06-3C10	500	500	410 500	310 500	(S-) DSHG-06-3H10	500	500	500	460 500
"11" 	DSHG-06-3C11	500	500	410 500	310 500	DSHG-06-3H11	500	500	500	460 500
"12" 	(S-) DSHG-06-3C12	500	500	410 500	310 500	(S-) DSHG-06-3H12	500	500	500	460 500

### ● Two Positions

Spool Type	No-Spring					Spring Offset				
	Graphic Symbol 	Maximum Flow L/min				Graphic Symbol 	Maximum Flow L/min			
		10 MPa	16 MPa	25 MPa	31.5 MPa		10 MPa	16 MPa	25 MPa	31.5 MPa
Model Numbers					Model Numbers					
"2" 	(S-) DSHG-06-2N2	500	500	500	500	(S-) DSHG-06-2B2	500	500	500	500
"3" 	DSHG-06-2N3	500	500	500	500	DSHG-06-2B3	500	500	500	500
"4" 	(S-) DSHG-06-2N4	500	500	500	500	(S-) DSHG-06-2B4	500	500	500	500
"40" 	(S-) DSHG-06-2N40	500	500	500	500	(S-) DSHG-06-2B40	500	500	500	500
"7" 	DSHG-06-2N7	500	500	500	500	DSHG-06-2B7	500	500	500	500

Notes: 1. The relation between max. flow and pilot pressure in the table above is as shown below.

#### (Example)

Maximum flow rate is constant regardless of pilot pressure.  
(Pilot Pressure more than 0.8 MPa. In case pressure centered models, pilot pressure is more than 1 MPa.)

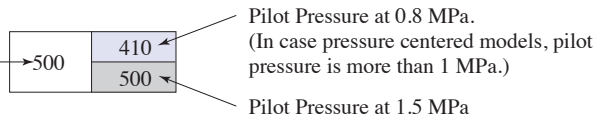





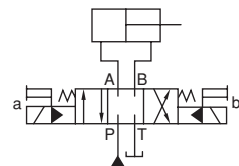





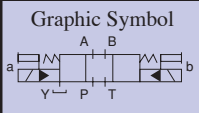
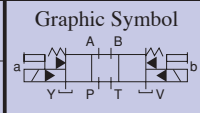

2. Max. flow in the table above represents the value in the flow condition of P → A → B → T (or P → B → A → T) as shown in the circuit diagram right.

In case the valve is used in the condition that either A or B port is blocked, the maximum flow differs according to a hydraulic circuit, therefore, please consult us for details.







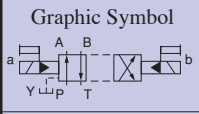
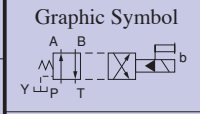

■ List of Standard Models (DSHG-10/S-DSHG-10)

● Three Positions

Spool Type	Spring Centered					Pressure Centered				
	Graphic Symbol 	Maximum Flow L/min				Graphic Symbol 	Maximum Flow L/min			
		10 MPa	16 MPa	25 MPa	31.5 MPa		10 MPa	16 MPa	25 MPa	31.5 MPa
Model Numbers					Model Numbers					
"2" 	(S-) DSHG-10-3C2	1100	1100	950 1100	750 1100	(S-) DSHG-10-3H2	1100	1100	1100	970 1100
"3" 	DSHG-10-3C3	1100	1100	1060	895	DSHG-10-3H3	1100	1100	1100	1050 1100
"4" 	(S-) DSHG-10-3C4	1100	1100	950 1100	750 1100	(S-) DSHG-10-3H4	1100	1100	1100	970 1100
"40" 	(S-) DSHG-10-3C40	1100	1100	950 1100	750 1100	(S-) DSHG-10-3H40	1100	1100	1100	970 1100
"5" 	DSHG-10-3C5	1100	1100	980	850	DSHG-10-3H5	1100	1100	1100	1000 1100
"6" 	DSHG-10-3C6	1050	880	700	570	DSHG-10-3H6	1100	1100	1100	970 1100
"60" 	(S-) DSHG-10-3C60	1050	940	785	680	(S-) DSHG-10-3H60	1100	1100	1100	970 1100
"7" 	DSHG-10-3C7	1100	1100	1040 1100	870 1100	DSHG-10-3H7	1100	1100	1100	1100
"9" 	DSHG-10-3C9	1100	1100	1040	870	DSHG-10-3H9	1100	1100	1100	1100
"10" 	(S-) DSHG-10-3C10	1100	1100	950 1100	750 1100	(S-) DSHG-10-3H10	1100	1100	1100	1060 1100
"11" 	DSHG-10-3C11	1100	1100	950 1100	750 1100	DSHG-10-3H11	1100	1100	1100	1060 1100
"12" 	(S-) DSHG-10-3C12	1100	1100	950 1100	750 1100	(S-) DSHG-10-3H12	1100	1100	1100	1060 1100

● Two Positions

Spool Type	No-Spring					Spring Offset				
	Graphic Symbol 	Maximum Flow L/min				Graphic Symbol 	Maximum Flow L/min			
		10 MPa	16 MPa	25 MPa	31.5 MPa		10 MPa	16 MPa	25 MPa	31.5 MPa
Model Numbers					Model Numbers					
"2" 	(S-) DSHG-10-2N2	1100	1100	1100	1100	(S-) DSHG-10-2B2	1100	1100	1100	1100
"3" 	DSHG-10-2N3	1100	1100	1100	1100	DSHG-10-2B3	1100	1100	1100	1100
"4" 	(S-) DSHG-10-2N4	1100	1100	1100	1100	(S-) DSHG-10-2B4	1100	1100	1100	1100
"40" 	(S-) DSHG-10-2N40	1100	1100	1100	1100	(S-) DSHG-10-2B40	1100	1100	1100	1100
"7" 	DSHG-10-2N7	1100	1100	1100	1100	DSHG-10-2B7	1100	1100	1100	1100

Notes ) 1. The relation between max. flow and pilot pressure in the table above is as shown below.

(Example)

Maximum flow rate is constant regardless of pilot pressure. Pilot Pressure more than 1 MPa.

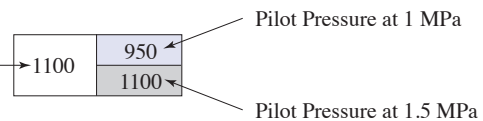

2. Max. flow in the table above represents the value in the flow condition of P → A → B → T (or P → B → A → T) as shown in the circuit diagram right.

In case the valve is used in the condition that either A or B port is blocked, the maximum flow differs according to a hydraulic circuit, therefore, please consult us for details.

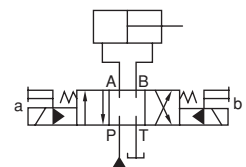

## Reverse Mounting of Solenoid

In spring offset type, it is a standard configuration that the solenoid is mounted onto the valve in the SOL b position (side). However, in this particular spool-spring arrangement, the mounting of the solenoid onto the valve in the reverse position - SOL a side - is also available. The graphic symbol for this reverse mounting is as shown below.

As for the valve type 2B \* A and 2B \* B, please refer to the explanation under the heading of "Valves Using Neutral Position and Side Position" given below.

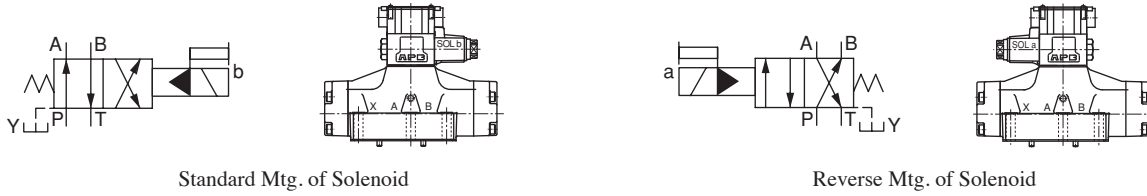

## Valves Using Neutral Position and Side Position

Besides the use of the standard 2-position valves aforementioned in the "List of Standard Models", the 3-position valves also can be used as the 2-position valves using the two of their three positions. In this case, there are two kinds of the valve available. One is the valve using the neutral position and SOL a position (2B \* A) and another is the valve using the neutral position and SOL b position (2B \* B).

(Example) In case of Spool Type "2"

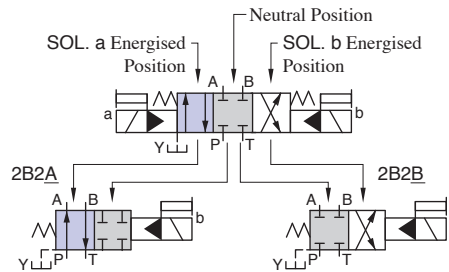

"A" : Use of Neutral and SOL. a Energised Position

"B" : Use of Neutral and SOL. b Energised Position

Model Numbers	Graphic Symbols		Model Numbers	Graphic Symbols		Model Numbers	Graphic Symbols
	Standard Mtg. Type	Reverse Mtg. Type		Standard Mtg. Type	Reverse Mtg. Type		Standard Mtg. Type
04 DSHG-06-2B * Δ 10			04 DSHG-06-2B * B 10			04 DSHG-06-2N * Δ 10	
(S-) DSHG- * -2B2A			(S-) DSHG- * -2B2B			(S-) DSHG- * -2N2A	
DSHG- * -2B3A			DSHG- * -2B3B			DSHG- * -2N3A	
(S-) DSHG- * -2B4A			(S-) DSHG- * -2B4B			(S-) DSHG- * -2N4A	
(S-) DSHG- * -2B40A			(S-) DSHG- * -2B40B			(S-) DSHG- * -2N40A	
DSHG- * -2B5A			DSHG- * -2B5B			DSHG- * -2N5A	
DSHG- * -2B6A			DSHG- * -2B6B			DSHG- * -2N6A	
(S-) DSHG- * -2B60A			(S-) DSHG- * -2B60B			(S-) DSHG- * -2N60A	
DSHG- * -2B7A			DSHG- * -2B7B			DSHG- * -2N7A	
DSHG- * -2B9A			DSHG- * -2B9B			DSHG- * -2N9A	
(S-) DSHG- * -2B10A			(S-) DSHG- * -2B10B			(S-) DSHG- * -2N10A	
DSHG- * -2B11A			DSHG- * -2B11B			DSHG- * -2N11A	
(S-) DSHG- * -2B12A			(S-) DSHG- * -2B12B			(S-) DSHG- * -2N12A	

Solenoid Controlled Pilot Operated Type

**Pressure Drop**

Pressure drop curves based on viscosity of 35 mm<sup>2</sup>/s and specific gravity of 0.850.

● DSHG-01

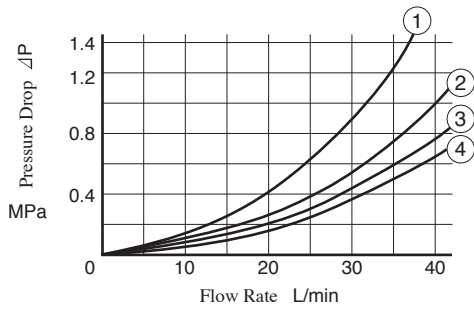

● DSHG-01

Spool Type	Pressure Drop Curve Number					Spool Type	Pressure Drop Curve Number				
	P→A	B→T	P→B	A→T	P→T		P→A	B→T	P→B	A→T	P→T
2	③	②	③	②	—	7	③	②	③	②	—
3	④	②	④	②	②	9	④	②	④	②	—
4	③	②	③	②	—	10	③	②	③	②	—
40	③	②	③	②	—	11	③	②	③	②	—
5	③	②	③	②	①	12	③	②	③	②	—
60	③	②	③	②	①						

● DSHG-03

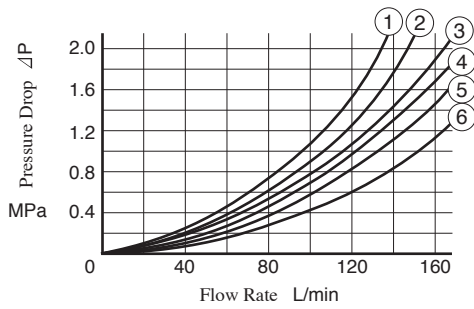

● DSHG-03

Spool Type	Pressure Drop Curve Number					Spool Type	Pressure Drop Curve Number				
	P→A	B→T	P→B	A→T	P→T		P→A	B→T	P→B	A→T	P→T
2	③	③	④	④	—	7	③	③	④	④	—
3	⑤	⑤	⑤	⑥	④	9	⑥	③	⑥	④	—
4	③	⑤	④	⑥	—	10	③	⑤	④	④	—
40	③	③	④	④	—	11	⑥	③	④	④	—
5	⑥	③	④	⑥	②	12	③	③	④	⑥	—
60	④	③	④	④	①						

● DSHG-04, S-DSHG-04

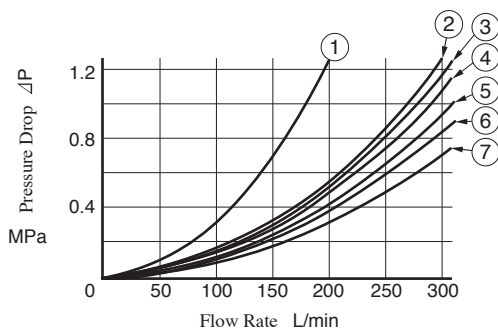

● DSHG-04

Spool Type	Pressure Drop Curve Number					Spool Type	Pressure Drop Curve Number				
	P→A	B→T	P→B	A→T	P→T		P→A	B→T	P→B	A→T	P→T
2	⑤	④	⑤	⑥	—	60	⑦	⑤	⑦	⑦	②
3	⑤	③	⑤	⑤	⑦	7	⑤	④	⑤	⑥	—
4	⑤	③	⑤	⑤	—	9	⑤	④	⑤	⑥	—
40	⑤	④	⑤	⑥	—	10	⑤	②	⑤	⑥	—
5	⑦	④	⑤	⑤	⑤	11	⑥	④	⑤	⑥	—
6	⑤	③	⑤	⑥	①	12	⑤	④	⑤	⑤	—

● S-DSHG-04

Spool Type	Pressure Drop Curve Number					Spool Type	Pressure Drop Curve Number				
	P→A	B→T	P→B	A→T	P→T		P→A	B→T	P→B	A→T	P→T
2	②	②	②	④	—	60	⑥	④	⑥	⑦	②
4	②	③	②	⑤	—	10	②	②	②	④	—
40	②	④	②	⑥	—	12	②	②	②	⑤	—

● DSHG-06、S-DSHG-06

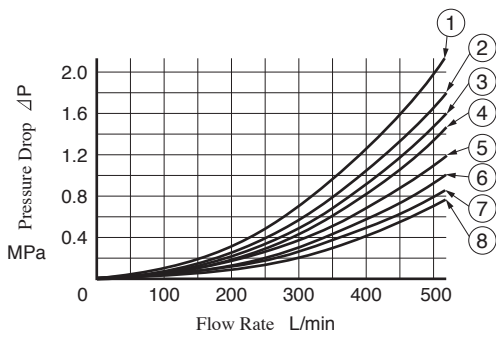

● DSHG-06

Spool Type	Pressure Drop Curve Number					Spool Type	Pressure Drop Curve Number				
	P→A	B→T	P→B	A→T	P→T		P→A	B→T	P→B	A→T	P→T
2	⑧	⑤	⑧	⑦	—	60	⑥	⑤	⑥	⑦	①
3	⑥	④	⑥	⑦	④	7	⑥	④	⑥	⑦	—
4	⑧	⑤	⑧	⑦	—	9	⑥	⑤	⑥	⑦	—
40	⑧	⑤	⑧	⑦	—	10	⑧	⑤	⑧	⑦	—
5	⑧	④	⑤	⑦	①	11	⑧	④	⑤	⑦	—
6	⑤	③	⑤	④	①	12	⑧	⑤	⑧	⑦	—

● S-DSHG-06

Spool Type	Pressure Drop Curve Number					Spool Type	Pressure Drop Curve Number				
	P→A	B→T	P→B	A→T	P→T		P→A	B→T	P→B	A→T	P→T
2	⑥	①	⑥	②	—	60	⑥	②	⑥	③	①
4	⑥	②	⑥	②	—	10	⑧	⑤	⑧	⑦	—
40	⑧	⑤	⑧	⑦	—	12	⑧	⑤	⑧	⑦	—

● DSHG-10、S-DSHG-10

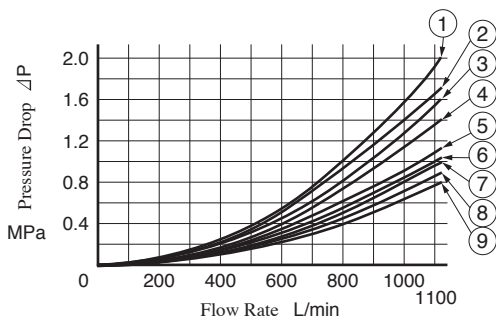

● DSHG-10

Spool Type	Pressure Drop Curve Number					Spool Type	Pressure Drop Curve Number				
	P→A	B→T	P→B	A→T	P→T		P→A	B→T	P→B	A→T	P→T
2	⑨	⑥	⑨	⑧	—	60	⑧	⑤	⑧	⑤	③
3	⑦	⑥	⑦	⑦	⑤	7	⑦	⑥	⑦	⑦	—
4	⑨	⑥	⑨	⑥	—	9	⑦	⑥	⑦	⑧	—
40	⑨	⑥	⑨	⑧	—	10	⑨	⑤	⑨	⑧	—
5	⑨	⑥	⑧	⑥	①	11	⑨	⑥	⑧	⑦	—
6	⑤	③	⑤	④	②	12	⑨	⑦	⑨	⑥	—

● S-DSHG-10

Spool Type	Pressure Drop Curve Number					Spool Type	Pressure Drop Curve Number				
	P→A	B→T	P→B	A→T	P→T		P→A	B→T	P→B	A→T	P→T
2	⑧	③	⑧	④	—	60	⑧	④	⑧	④	②
4	⑧	⑤	⑧	⑥	—	10	⑨	⑤	⑨	⑧	—
40	⑨	⑥	⑨	⑧	—	12	⑨	⑦	⑨	⑥	—

● For any other viscosity, multiply the factors in the table below.

Viscosity mm <sup>2</sup> /s	15	20	30	40	50	60	70	80	90	100
Factor	0.81	0.87	0.96	1.03	1.09	1.14	1.19	1.23	1.27	1.30

● For any other specific gravity (G'), the pressure drop (ΔP') may be obtained from the formula below.  
 $\Delta P' = \Delta P(G'/0.850)$

**Typical Changeover Time**

Changeover time varies according to oil viscosity, spool type and hydraulic circuit.

**Test Conditions**

Coil Type : D \* (Models with DC solenoids)

Voltage : Rated Voltage

Oil Viscosity : 35 mm<sup>2</sup>/s

● **DSHG-04**

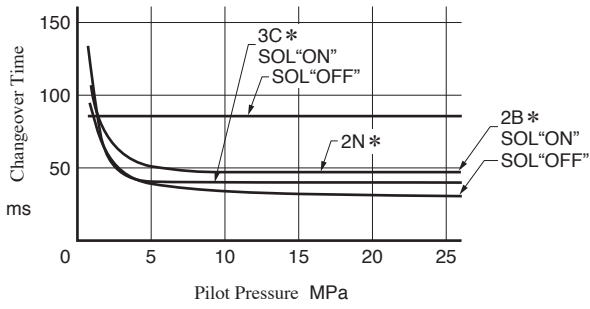

● **DSHG-10**

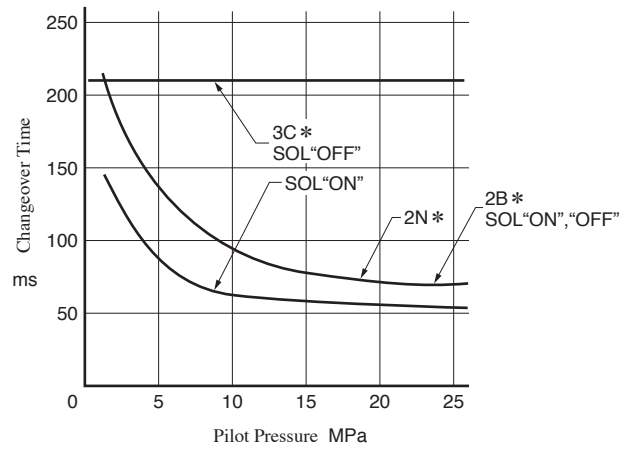

● **DSHG-06**

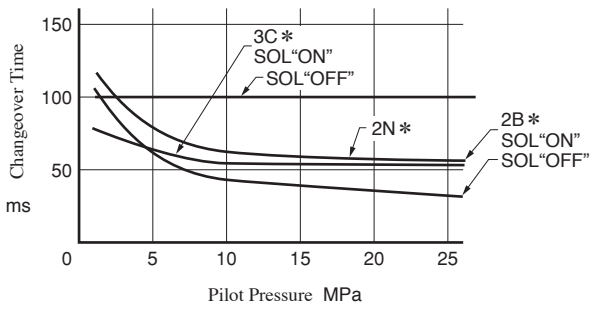

## DSHG-01

Mounting Surface: ISO 4401-03-02-0-05

- Internal Pilot - Internal Drain

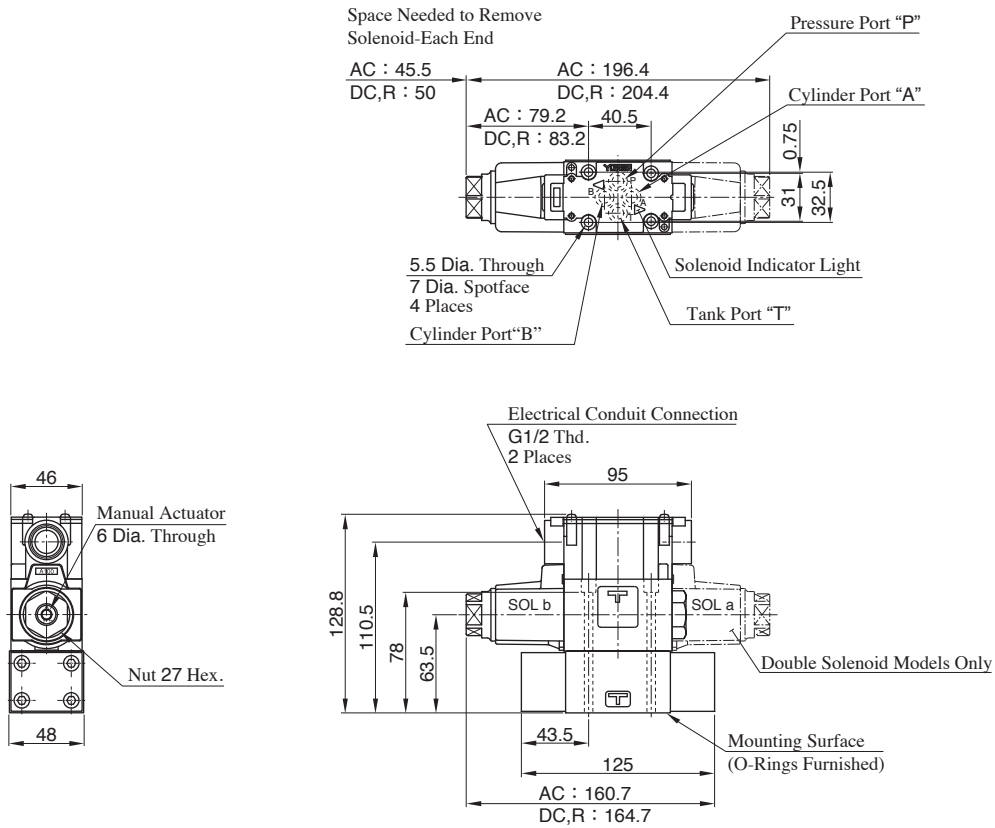

Note) Valves that position of cable departure can change plug-in connector type are also available.  
For details, refer to DSG-01 valve on page E-32.

- External Pilot - External Drain
- External Pilot - Internal Drain
- Internal Pilot - External Drain

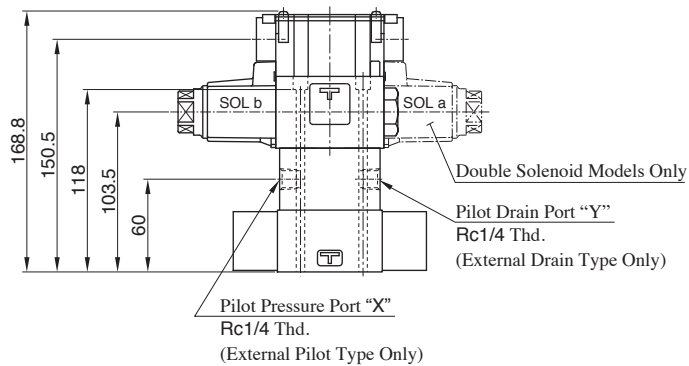

- For other dimensions, refer to "Internal Pilot / Internal Drain Type".



**DSHG-03**

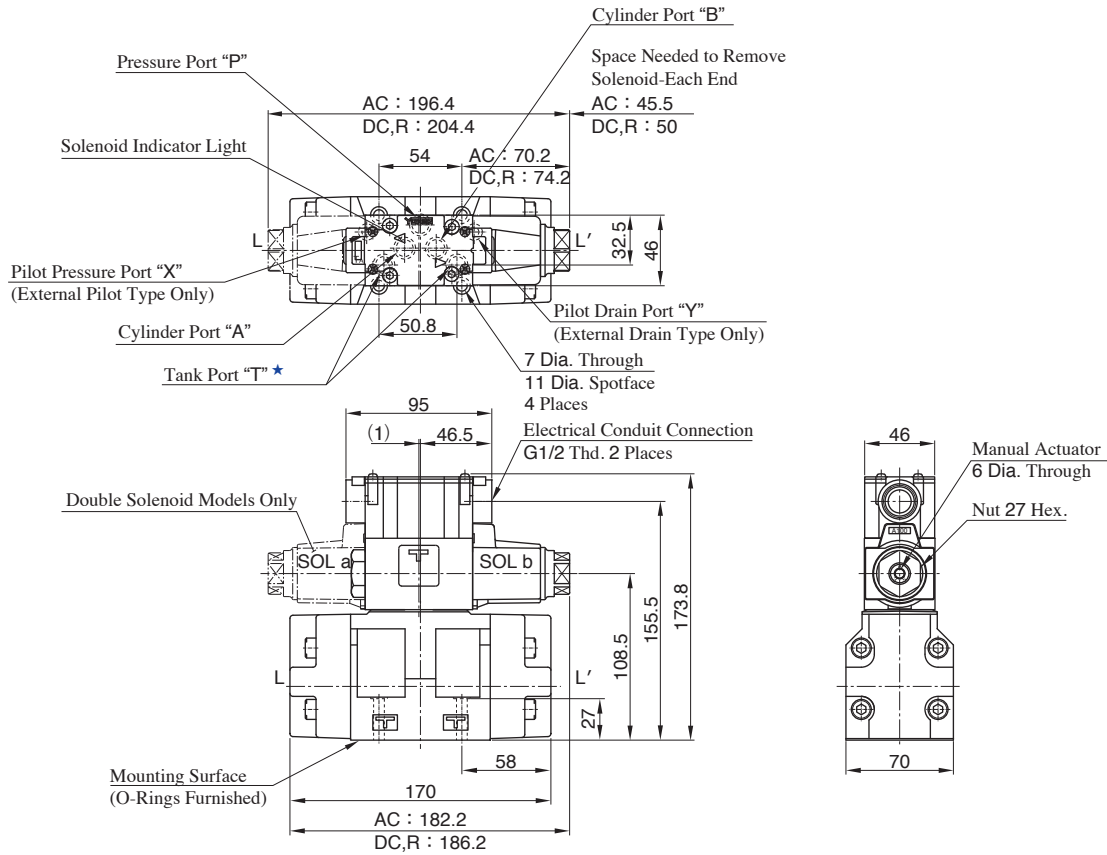

★Of the two of tank port "T", the tank port in the left side is normally used in our standard sub-plate, though, either side of the tank port "T" can be used without problem.

Note) Valves that position of cable departure can change plug-in connector type are also available.  
For details, refer to DSG-01 valve on page E-32.

**Sub-plate**

**DHGM-03Y**

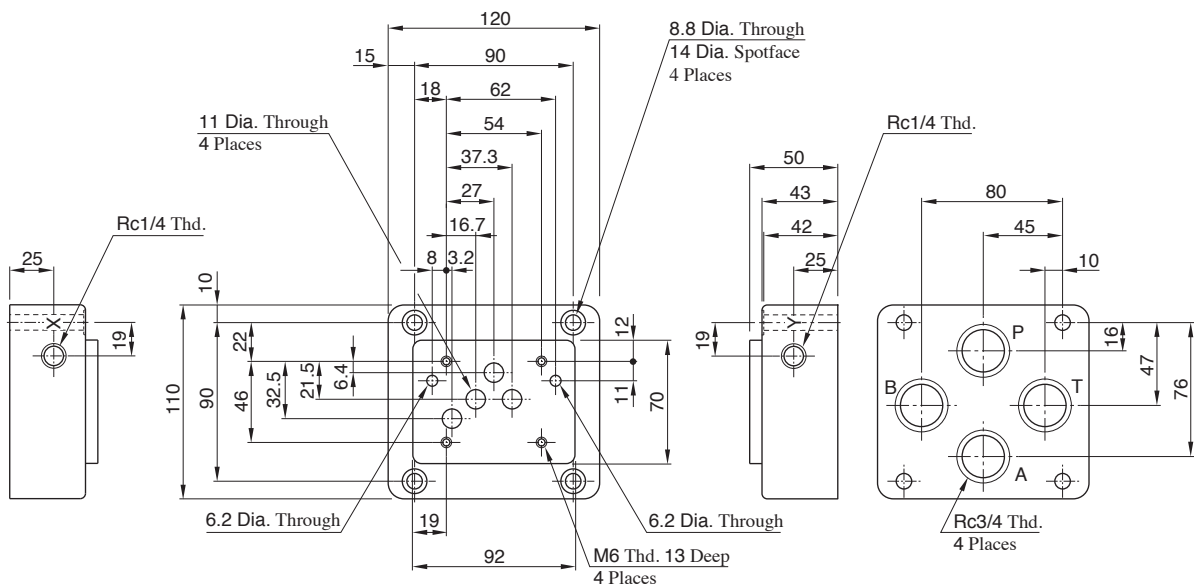



## (S-) DSHG-04

Mounting Surface: ISO 4401-07-07-0-05

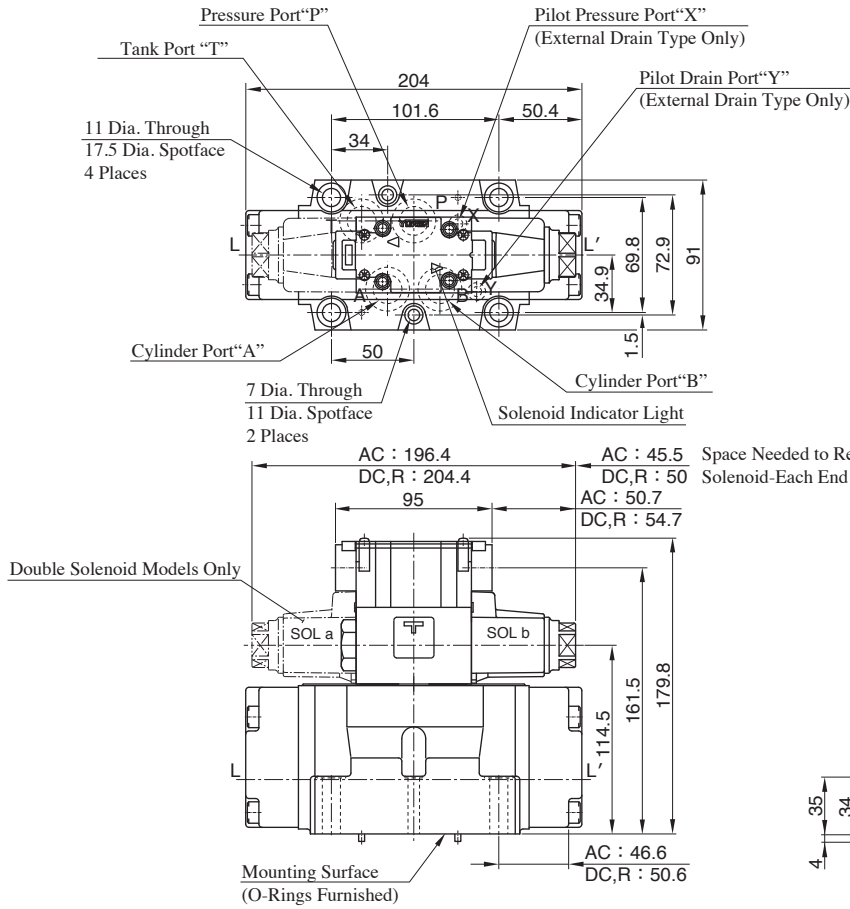

Note) Valves that position of cable departure can change plug-in connector type are also available.  
For details, refer to DSG-01 valve on page E-32.

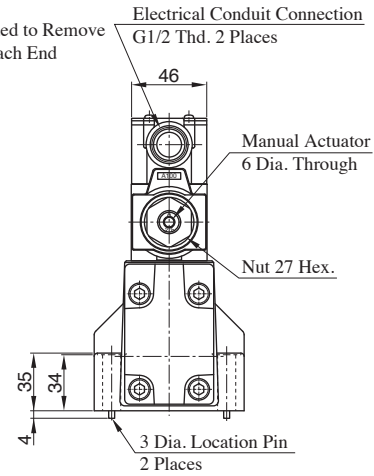

### Sub-plate DHGM-04, 04X

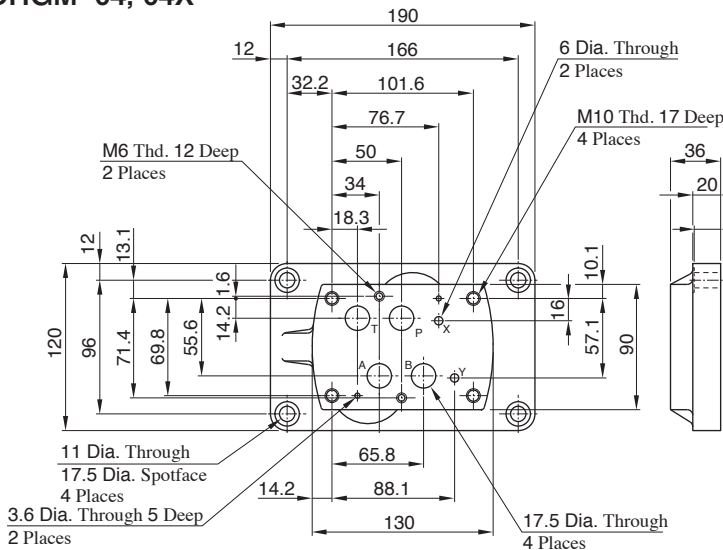

Sub-plate Model Numbers	D
DHGM-04	1/2
DHGM-04X	3/4

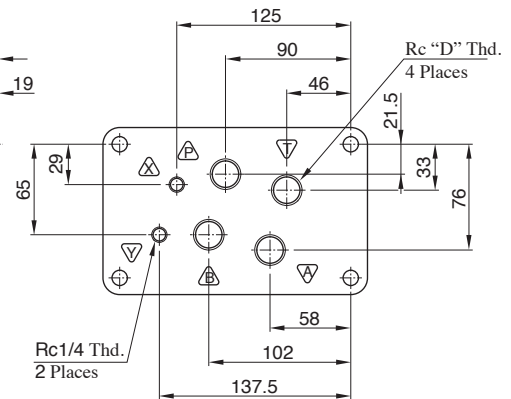

Note) Use Type of Port "X" and "Y"

Pilot Pressure Port "X"	Drain Port "Y"
Used only on external pilot type valves. To be plugged on internal pilot type valves.	Used as drain port only on external drain type valves. To be plugged on internal drain type valves.

Solenoid Controlled Pilot Operated Type

**(S-) DSHG-06**

Mounting Surface: ISO 4401-08-08-0-05

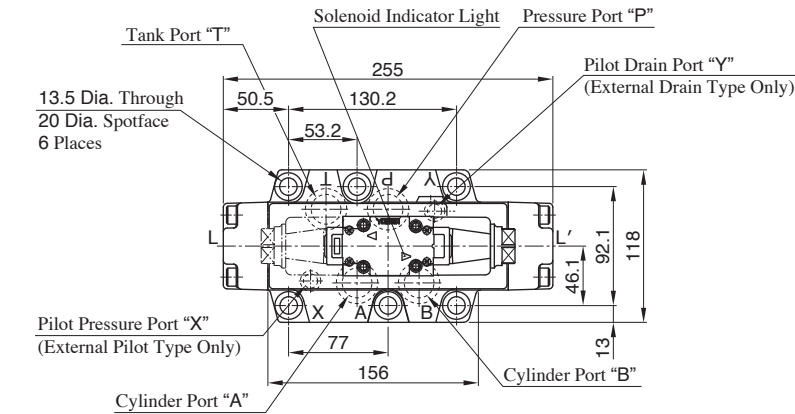

Note) Valves that position of cable departure can change plug-in connector type are also available.  
For details, refer to DSG-01 valve on page E-32.

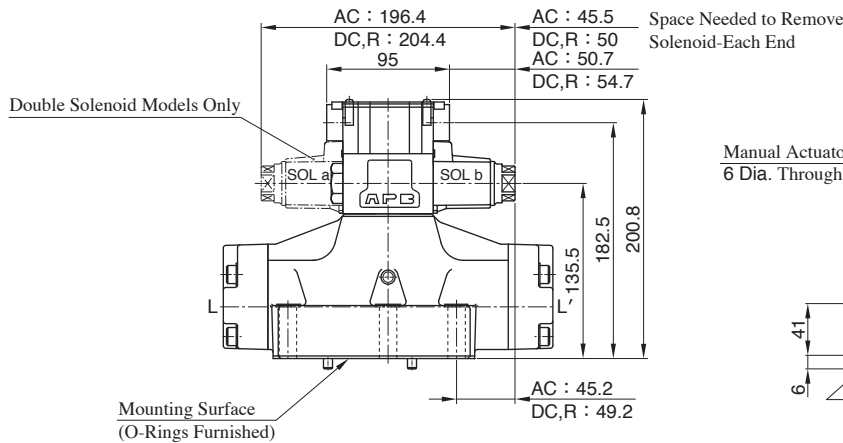

Space Needed to Remove Solenoid-Each End

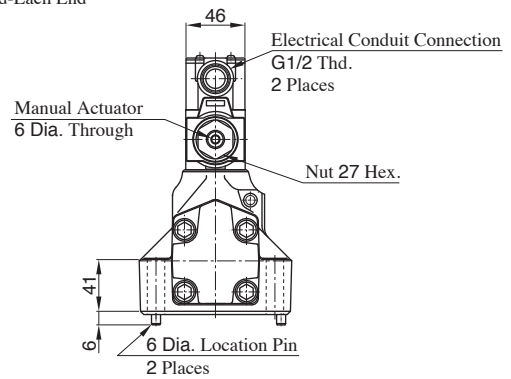

**(S-) DSHG-10**

Mounting Surface: ISO 4401-10-09-0-05

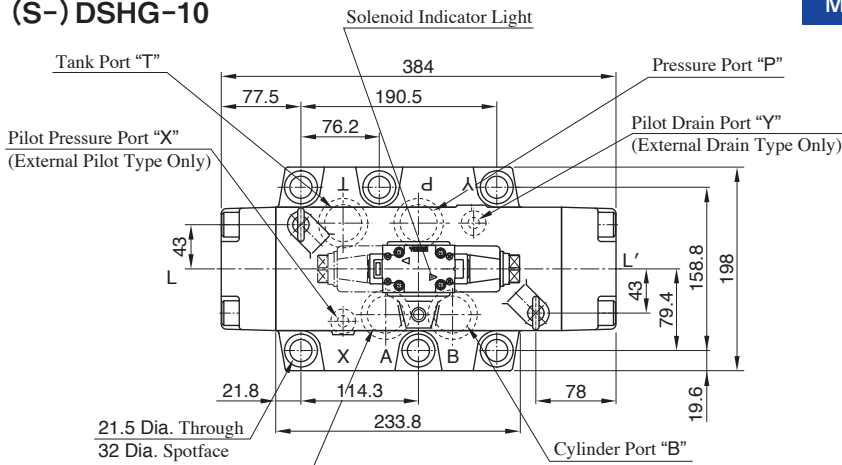

Note) Valves that position of cable departure can change plug-in connector type are also available.  
For details, refer to DSG-01 valve on page E-32.

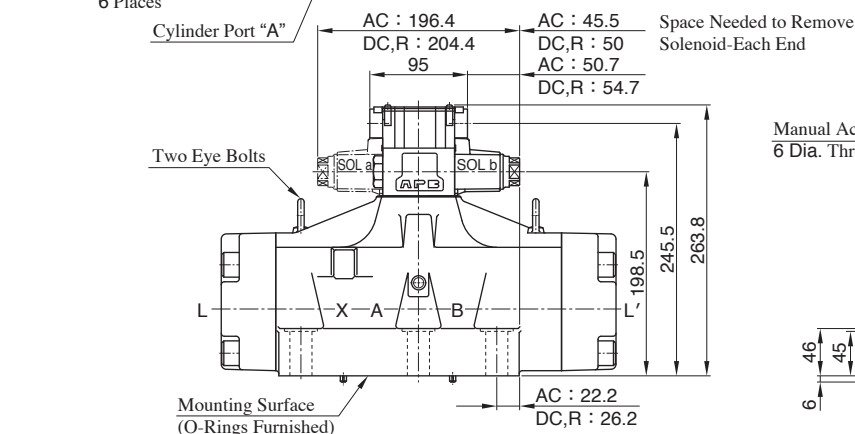

Space Needed to Remove Solenoid-Each End

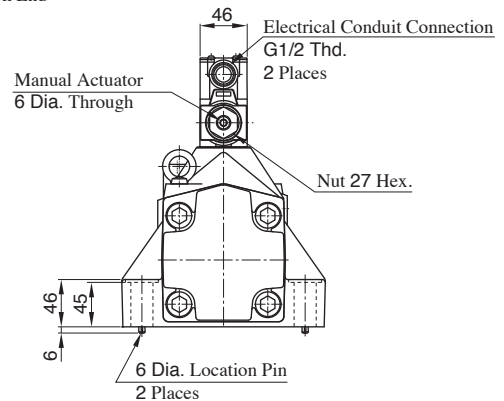

## Sub-plate DHGM-06, 06X

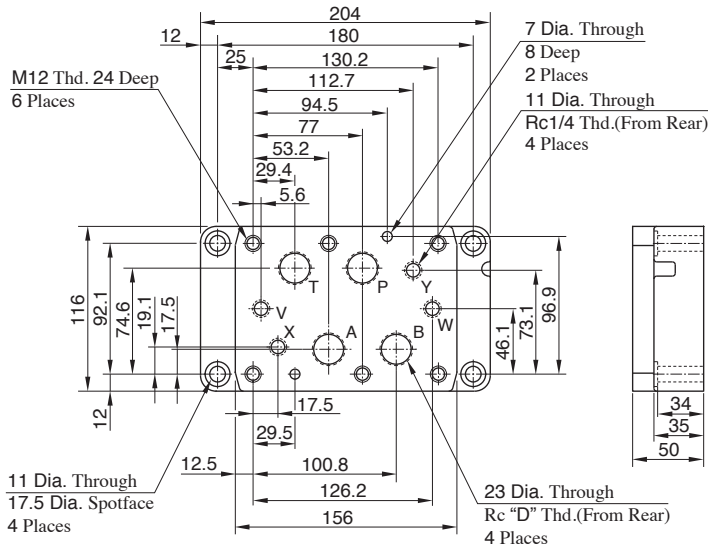

Sub-plate Model Numbers	"D"
DHGM-06	3/4
DHGM-06X	1

## DHGM-10, 10X

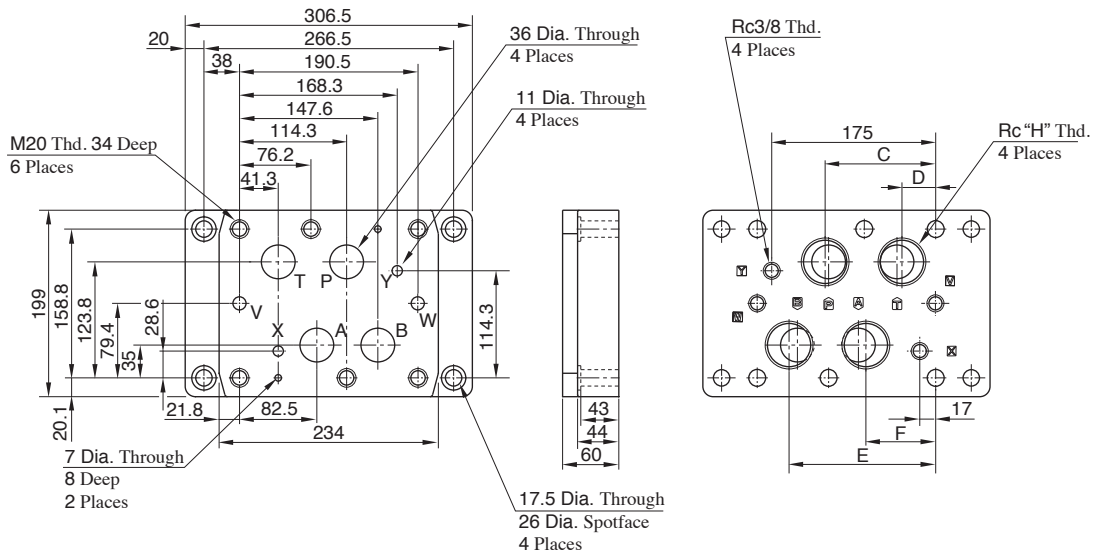

Sub-plate Model Numbers	C	D	E	F	H
DHGM-10	114	41	147.5	82.5	1 1/4
DHGM-10X	118	36	156.5	74.5	1 1/2

Note) Use Type of Port "X", "Y", "V" and "W"

Valve Types	Pilot Pres. Port "X"	Pilot Drain Port "Y"	Drain Port "V"	Drain Port "W"
Spring Centered, No-Spring, Spring Offset	Used only on external pilot type valves.	Used as drain port only on external drain type valves.	Not used (plug is not required)	
Pressure Centered			Used	Not used (plug is not required)
With Pilot Piston, Both Ends	To be plugged on internal pilot type valves.	To be plugged on* internal drain type valves.	Used	Used
With Pilot Piston, Port "A" End			Used	Not used (plug is required)
With Pilot Piston, Port "B" End			Not used (plug is required)	Used

\* As the thread is provided on the body, plug either port on the sub-plate or port on the body.



**Options**

■ Models with Pilot Choke Valve

● DSHG-03-\*\*\*-C1, C2, C1C2

● (S-) DSHG-06-10-\*\*\*-C1, C2, C1C2

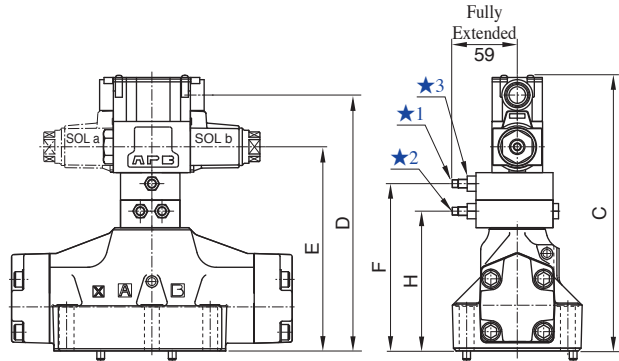
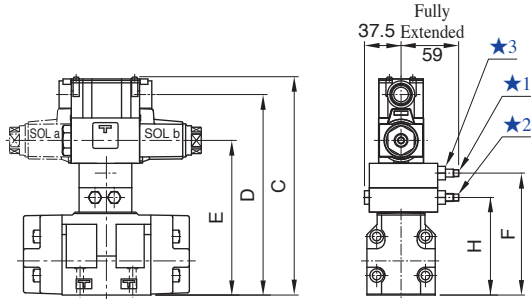

● (S-) DSHG-04-\*\*\*-C1, C2, C1C2

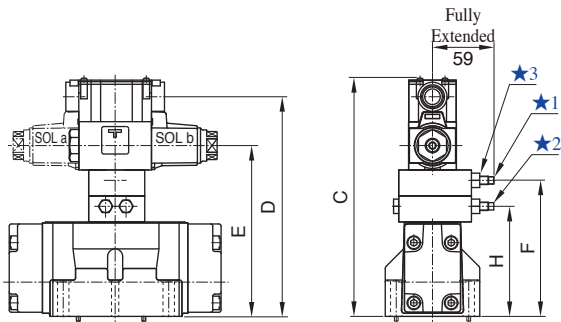

- ★ 1. "C1" Choke (Meter-in) Adj. Screw 6 Hex.
- ★ 2. "C2" Choke (Meter-out) Adj. Screw 6 Hex.
- ★ 3. Lock Nut 12 Hex.

Model Numbers	C	D	E	F	H
DSHG-03-***-C1	198.8	180.5	133.5	100	—
DSHG-03-***-C2				—	100
DSHG-03-***-C1C2	223.8	205.5	158.5	125	100
(S-) DSHG-04-***-C1	204.8	186.5	139.5	106	—
(S-) DSHG-04-***-C2				—	106
(S-) DSHG-04-***-C1C2	229.8	211.5	164.5	131	106
(S-) DSHG-06-***-C1	225.8	207.5	160.5	127	—
(S-) DSHG-06-***-C2				—	127
(S-) DSHG-06-***-C1C2	250.8	232.5	185.5	152	127
(S-) DSHG-10-***-C1	288.8	270.5	223.5	190	—
(S-) DSHG-10-***-C2				—	190
(S-) DSHG-10-***-C1C2	313.8	295.5	248.5	215	190

## Options

### Models with Stroke Adjustment

- DSHG-03-\*\*\*-R\*

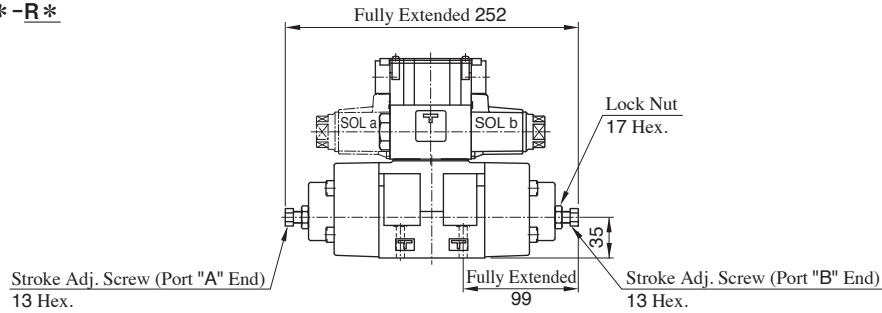

- (S-) DSHG-04-\*\*\*-R\*

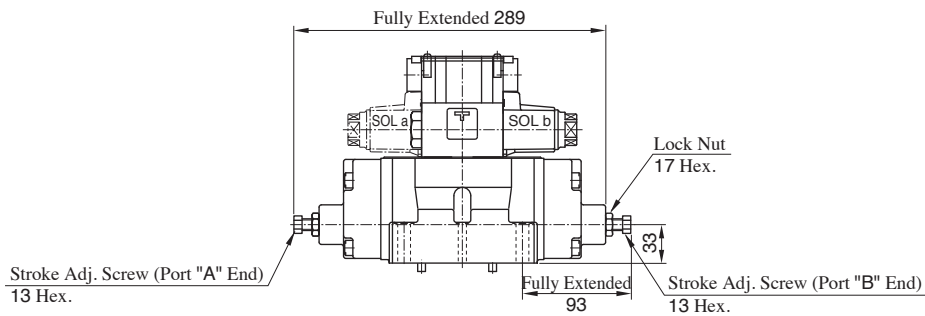

- (S-) DSHG-<sup>06</sup>/<sub>10</sub>-\*\*\*-R\*

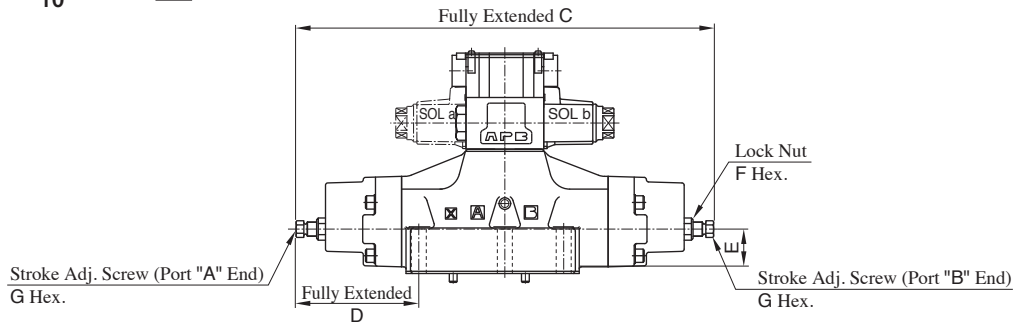

Model Numbers	C	D	E	F	G
(S-) DSHG-06-***-R2	376	111	40	19	13
(S-) DSHG-10-***-R2	558	164.5	65	24	17

### Pressure Centered Models

- (S-) DSHG-<sup>06</sup>/<sub>10</sub>-3H\*

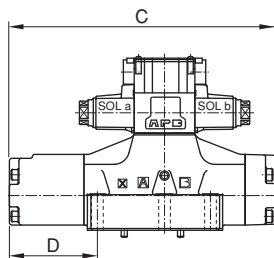

Model Numbers	C	D
(S-) DSHG-06-3H*	306.5	102
(S-) DSHG-10-3H*	456	149.5

### Models with Pilot Piston

- (S-) DSHG-<sup>06</sup>/<sub>10</sub>-\*\*\*-P\*

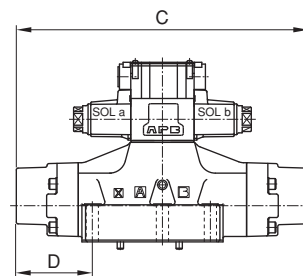

Model Numbers	C	D
(S-) DSHG-06-***-P2	323	84
(S-) DSHG-10-***-P2	479	125



**List of Seals and Pilot Valves**

**DSHG-01**

Socket Head Cap Plug  
R1/4 Thd.  
This plug used only for  
Internal Pilot Models.  
Removed for External  
Pilot Models

Socket Head Cap Plug  
R1/4 Thd.  
This plug used only for Internal Drain Models.  
Removed for External Drain Models

Socket Head Cap Plug (NPT 1/16) Thd.  
This plug used only for External Pilot Models.  
Removed for Internal Pilot Models

Socket Head Cap Plug (NPT 1/16) Thd.  
This plug used only for External Drain Models.  
Removed for Internal Drain Models

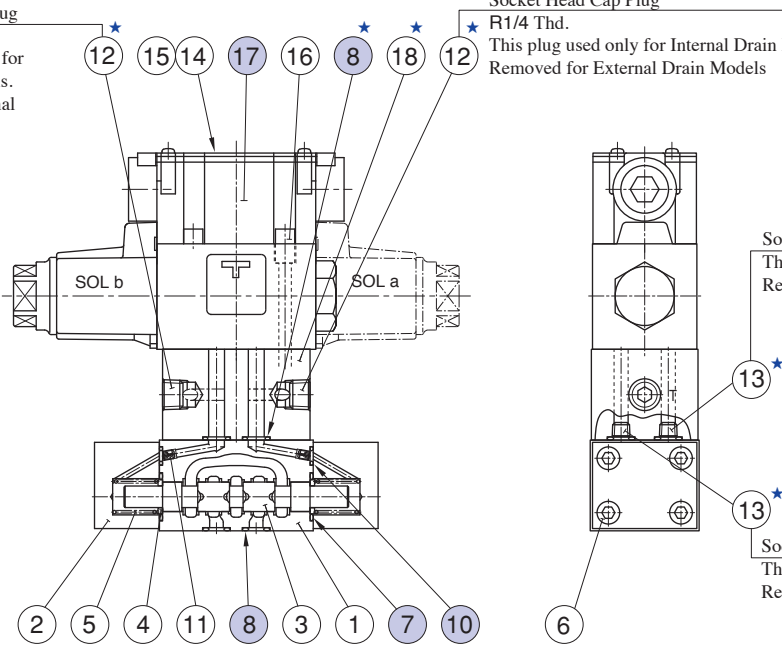

Note: Piece parts marked ★ are not available for internal pilot-internal drain type.

**List of Seals**

Item	Name	Part Numbers	Qty.
7	O-Ring	JASO 1018 1A	2
8		OR NBR-90 P9-N	8 (4) ★ <sup>1</sup>
10		OR NBR-90 P5-N	2

★1. Quantities in the ( ) are applicable to internal pilot-internal drain.

**List of Item ⑰ Pilot Valves**

Solenoid Controlled Pilot Operated Directional Valve Model Numbers	⑰ Pilot Valve Model Numbers
DSHG-01-3C * -★-14	DSG-01-3C4-★-70
DSHG-01-2B * -★-14	DSG-01-2B2-★-70-L

Note) Fill coil type (a symbol representing current/voltage) in section marked ★.  
For the details of the pilot valves, refer to page E-34 for DSG-01 series.

## List of Seals and Pilot Valves

### DSHG-03

Throttle Taper Thread Plug  
Used only for 2B\* and 2N\*  
Removed for 3C\*

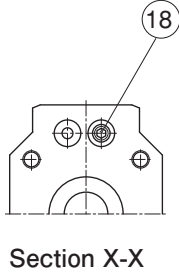

Section X-X

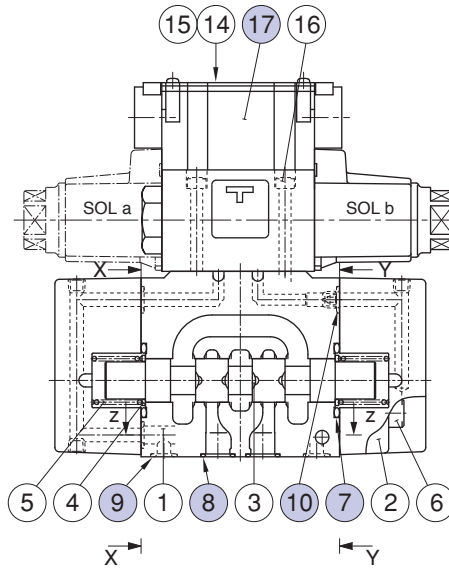

Throttle Taper Thread Plug  
Used only for 2B\* and 2N\*  
Removed for 3C\*

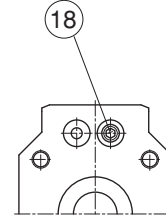

Section Y-Y

Socket Head Cap Plug (NPT 1/16) Thd.  
Used only for External Pilot Models  
Removed for Internal Pilot Models

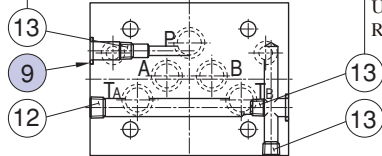

Section Z-Z

Socket Head Cap Plug (NPT 1/16) Thd.  
Used only for External Drain Models  
Removed for Internal Drain Models

#### List of Seals

Item	Name	Part Numbers	Qty.
7	O-Ring	OR NBR-90 P28-N	2
8		AS568-014 (NBR-90)	5
9		OR NBR-90 P9-N	2
10		OR NBR-90 P9-N	6

#### List of Item 17 Pilot Valves

Solenoid Controlled Pilot Operated Directional Valve Model Numbers	17 Pilot Valve Model Numbers
DSHG-03-3C*-★-14	DSG-01-3C4-★-70
DSHG-03-2B*-★-14	DSG-01-2B2-★-70
DSHG-03-2N*-★-14	DSG-01-2D2-★-70

Note) Fill coil type (a symbol representing current/voltage) in section marked ★.

For the details of the pilot valves, refer to page E-34 for DSG-01 series.

■ List of Seals and Pilot Valves

(S-) DSHG-04

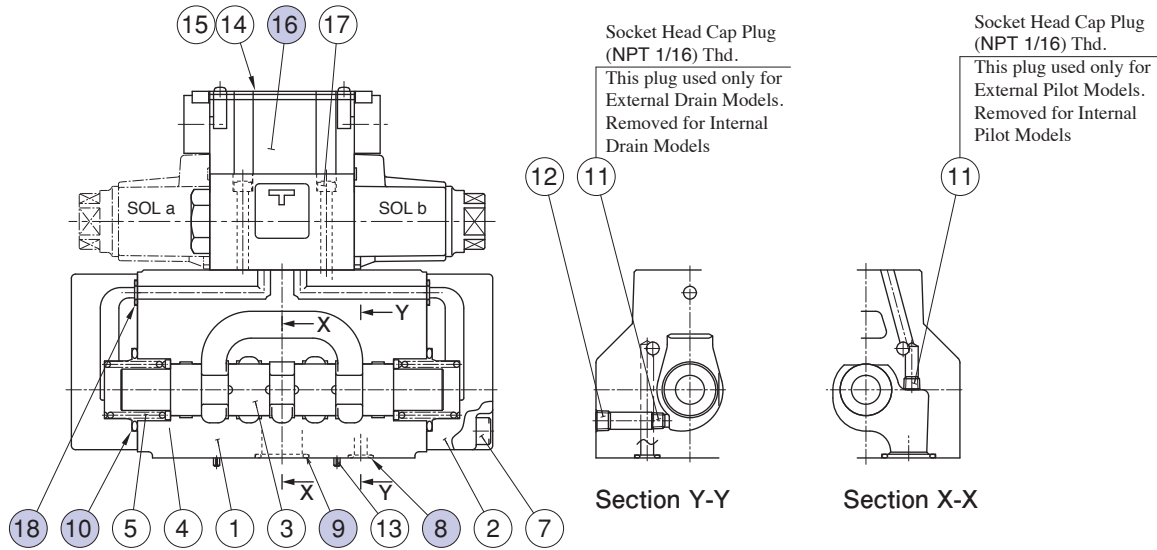

● List of Seals

Item	Name	Part Numbers	Qty.
8	O-Ring	OR NBR-90 P9-N	2
9		OR NBR-90 P22-N	4
10		OR NBR-90 P34-N	2
18		OR NBR-90 P9-N	2

● List of Item 16 Pilot Valves

Solenoid Controlled Pilot Operated Directional Valve Model Numbers	16 Pilot Valve Model Numbers
(S-) DSHG-04-3C * -★-52	DSG-01-3C4-★-70
(S-) DSHG-04-2N * -★-52	DSG-01-2D2-★-70
(S-) DSHG-04-2B * -★-52	DSG-01-2B2-★-70

Note) Fill coil type (a symbol representing current/voltage) in section marked ★.  
For the details of the pilot valves, refer to page E-34 for DSG-01 series.



## List of Seals and Pilot Valves

### (S-) DSHG-06, 10

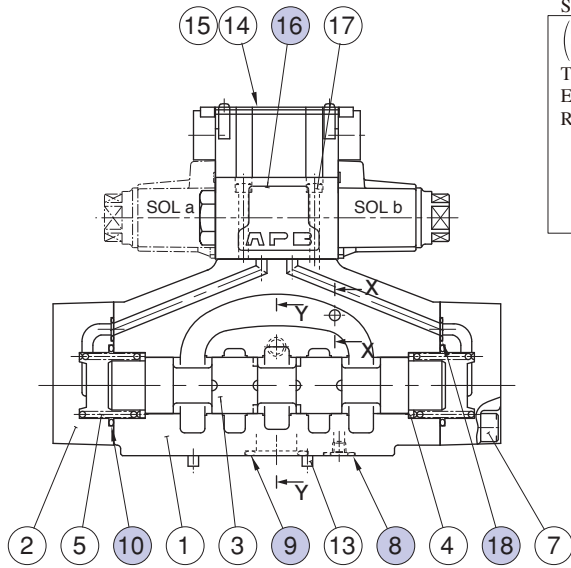

Socket Head Cap Plug  
(DSHG-06 .....(NPT 1/16) Thd.)  
(DSHG-10 .....(R 1/8) Thd.)  
This plug used only for  
External Pilot Models.  
Removed for Internal Pilot Models

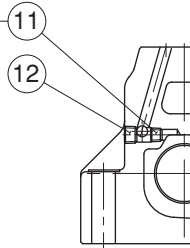

Section Y-Y

Socket Head Cap Plug  
(DSHG-06 .....(NPT 1/16) Thd.)  
(DSHG-10 .....(R 1/8) Thd.)  
This plug used only for  
External Drain Models.  
Removed for Internal Drain Models

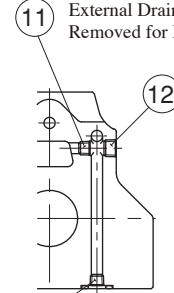

Section X-X

Socket Head Cap Plug  
(DSHG-06 .....(NPT 1/16) Thd.)  
(DSHG-10 .....(R 1/8) Thd.)  
This plug used only for  
Internal Drain Models.  
Removed for External Drain Models

#### List of Seals

Item	Name	Part Numbers		Qty.
		(S-) DSHG-06	(S-) DSHG-10	
8	O-Ring	OR NBR-90 P14-N	OR NBR-90 P20-N	2
9		OR NBR-90 P30-N	OR NBR-90 P42-N	4
10		OR NBR-90 P40-N	OR NBR-90 G65-N	2
18		OR NBR-90 P10-N	OR NBR-90 P14-N	2

#### List of Item 16 Pilot Valves

Solenoid Controlled Pilot Operated Directional Valve Model Numbers	16 Pilot Valve Model Numbers
(S-) DSHG-06-3C * -★-53	DSG-01-3C4-★-70
(S-) DSHG-10-3C * -★-43	
(S-) DSHG-06-2N * -★-53	DSG-01-2D2-★-70
(S-) DSHG-10-2N * -★-43	
(S-) DSHG-06-2B * -★-53	DSG-01-2B2-★-70-L
(S-) DSHG-10-2B * -★-43	
(S-) DSHG-06-3H * -★-53	DSG-01-3C9-★-70
(S-) DSHG-10-3H * -★-43	

Note) Fill coil type (a symbol representing current/voltage) in section marked ★.

For the details of the pilot valves, refer to page E-34 for DSG-01 series.

