

Series Variable Displacement Piston Pumps

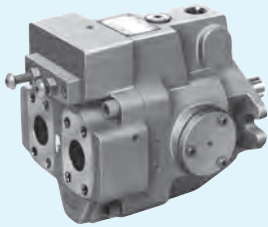

A37



A16

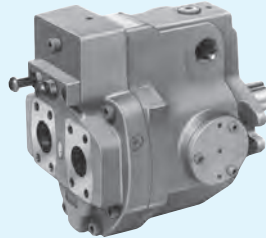

A56



A10

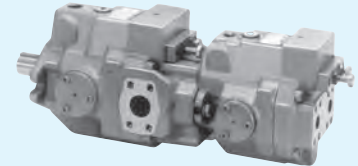

A1637

“A” Series Variable Displacement Piston Pumps

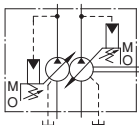
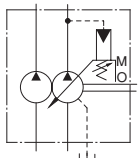
Pump Type	Graphic Symbol	Geometric Displacement cm ³ /rev							Maximum Operating Pressure MPa	Page			
		1	2	5	10	20	50	100			200	300	
Single Pumps ^{★1}		A10									21	A-25	
		A16									16		
		A22									21		
		A37									16		
		A45									21		
		A56									28		
		A70									21		
		A90									28		
Double Pumps		Outboard Pump									28 ^{★2}	A-107	
		Inboard Pump											
		Outboard Pump											
		Inboard Pump											
Variable/Fixed Double Pumps		Outboard Pump									28 ^{★2}	A-109	
		Inboard Pump											

^{★1} Various control types are available such as pressure compensator type. Refer to page A-26 and A-27.

^{★2} The maximum operating pressure for each double pump depends on its combination of pumps. Contact us for details.

Hydraulic Fluids

Hydraulic Fluids

Use petroleum based oils such as anti-wear type hydraulic oils equivalent to ISO VG-32 or 46. The recommended viscosity range is from 20 to 400 mm²/s and temperature range is from 0 to 60°C, both of which have to be satisfied for the use of the above hydraulic oils.

Control of Contamination

Due caution must be paid to maintaining control over contamination of the operating oil which can otherwise lead to breakdowns and shorten the life of the unit.

Please maintain the degree of contamination within NAS Grade 10.

The suction port must be equipped with at least a 100 μm (150 mesh) reservoir type filter and the return line must have a line type filter of under 10 μm.

Instructions

Mounting

When installing the pump the filling port should be positioned upwards.

Alignment of Shaft

Employ a flexible coupling whenever possible, and avoid any stress from bending or thrust.

Maximum permissible misalignment is less than 0.1 mm TIR and maximum permissible misangular is less than 0.2°.

Suction Pressure

Permissible suction pressure at inlet port of the pump is between -16.7 and +50 kPa.

For piping to the suction port, use the pipes of the same diameter as that of the specified pipe flange to be used. Make sure that the height of the pump suction port is within one meter from the oil level in the reservoir.

Hints on Piping

When using steel pipes for the suction or discharge ports, excessive load from the piping to the pump generates excessive noise.

Whenever there is fear of excessive load, please use rubber hoses.

Suction Piping

In case the pump is installed above the oil level, the suction piping and suction line filter should be located lower than the pump position to prevent air in the suction line.

When using steel pipes for the suction or discharge ports, excessive load from the piping to the pump generates excessive noise.

Whenever there is fear of excessive load, please use rubber hoses.

Drain Piping

Install drain piping according to the chart and ensure that pressure within the pump housing should be maintained at a normal pressure of less than 0.1 MPa and surge pressure of less than 0.5 MPa.

Length of piping should be less than 1 m, and the pipe end should be submerged in oil.

[Recommended Drain Piping Size]

Model	Fitting Size	Inside Dia. of Pipe
A10, A16, A22	3/8 [Inside Dia. 8.5 mm or more]	10 mm or more
A37, A45	1/2 [Inside Dia. 12 mm or more]	12 mm or more
A56, A70, A90, A100, A145	3/4 [Inside Dia. 16 mm or more]	19 mm or more

Bleeding Air

It may be necessary to bleed air from pump case and outlet line to remove causes of vibration. An air bleed valve (Model Number ST1004-*-10*, Page A-259) is recommended for this purpose.

Starting

Before first starting, fill pump case with clean operating oil via the filling port.

In order to avoid air blockage when first starting, adjust the control valves so that the discharged oil from the pump is returned direct to the reservoir or the actuator moves in a free load.

[Volume of Pre-fill Oil Required]

Model	Volume cm ³
A10	370
A16/A22	600
A37/A45/A56	1200
A70	2100
A90/A100	2500
A145	3300

Setting Discharge Pressure and Delivery

At the time of shipment, the unit has been preset to maximum delivery and minimum discharge pressure.

Adjust the preset delivery and pressure to meet your system requirements.

Adjustment of Discharge Pressure

Turning the adjustment screw clockwise, increases pressure.

[Volume adjusted by each full turn of the pressure adjustment screw]

Model Numbers	Adjustment Volume MPa
A10-FR01B	2.9
A10-FR01C/H	5.4
A16/A22/A37/A45/A56- *-R-01-B	3.5
A16/A22/A37/A45/A56- *-R-01-C	6.5
A16/A37/A56- *-R-01-H	7.9
A70/A90/A100/A145- *-R01B	2.3
A70/A90/A100/A145- *-R01C	3.2
A70/A90/A100/A145- *-R01H	4.0
A70/A90/A100/A145- *-R01K	4.7

Adjustment of Delivery

Turning the flow adjustment screw clockwise, decreases delivery.

[The minimum adjustable flow and adjustable volume of each full turn of the delivery adjustment screw]

Model	Adjustable volume with each full turn of the adjustment screw cm ³ /rev	Minimum Adjustable Flow cm ³ /rev
A10	1.1	2.0
A16	1.4	4.0
A22	2.0	6.0
A37/A45	2.9	10
A56	3.9	12
A70	4.4	36
A90	4.8	56
A100	5.2	62
A145	7.2	83

Series Variable Displacement Piston Pumps

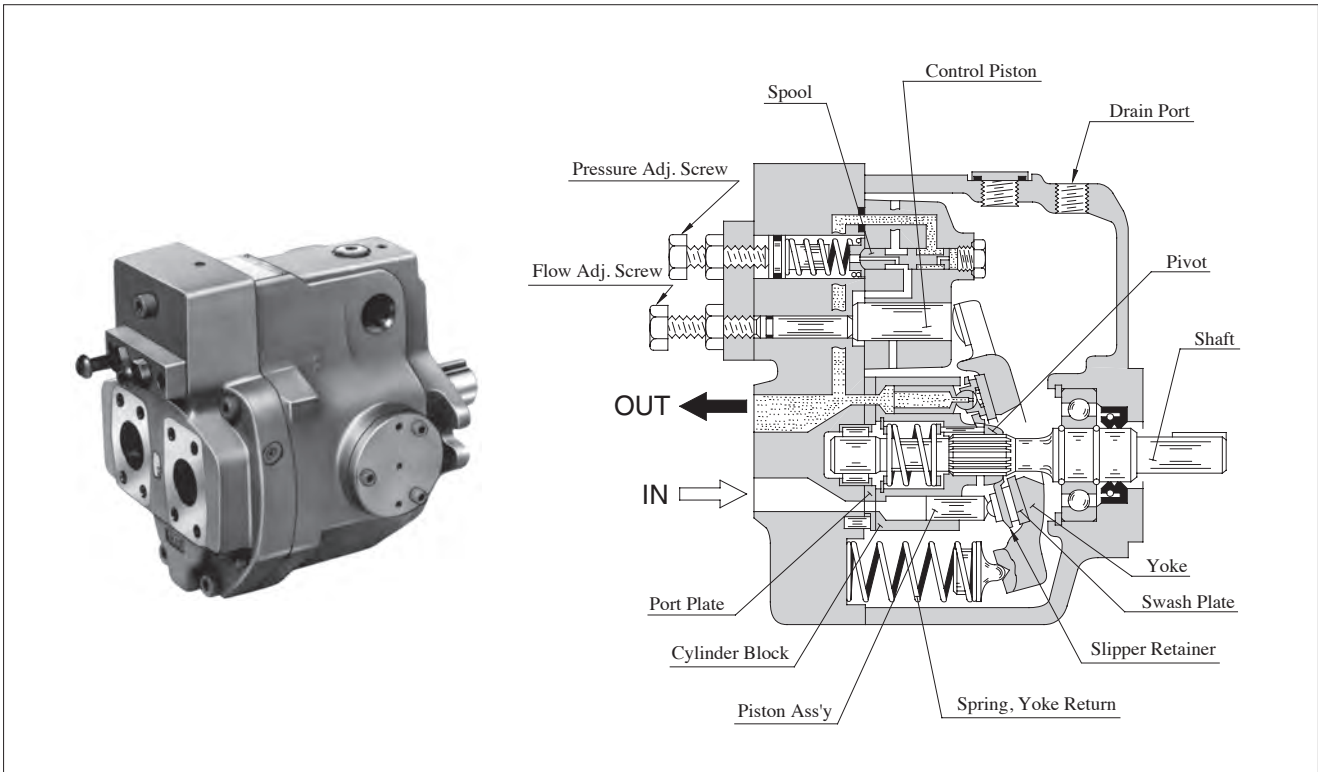

■ Features

● High efficiency

The efficiency properties in case of “A16” pump are high efficiencies to be shown below.

● Low noise level

In the “A16” pump, the noise level is as low as 57.3 dB(A) [at the full cut-off pressure 21 MPa with speed 1500 r/min one meter horizontally away from pump head cover.]

“A16” Type Performance Characteristics

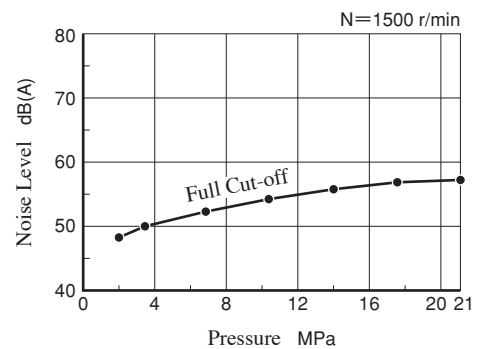
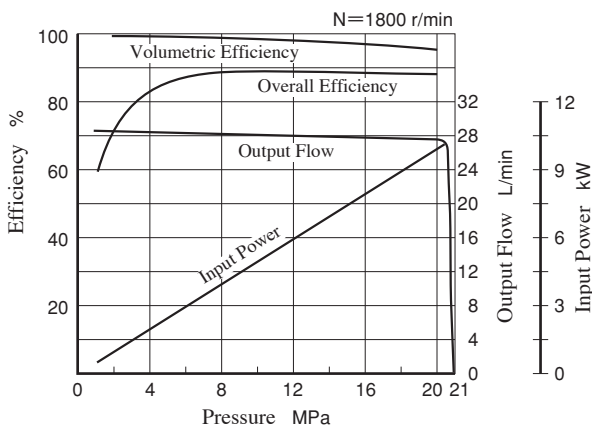

● Accomplishment of energy-saving

Because the overall efficiency is high and the cut-off characteristics is sharp, thus the input power may be saved.

● Low heat generation

Because of small power loss, it is possible to reduce the rise in oil temperature. Accordingly, capacity of a reservoir can be reduced.

Control Type

Control Type	Graphic Symbols	Performance Characteristics	Explanation	Page
"01" Pressure Compensator Type			When the system pressure increases and comes close to the preset cut-off pressure, the pump flow decreases automatically while maintaining the set pressure as it is.	A-28
"02" Solenoid Two Pressure Control Type			This type of control is ideal for an application where the output power of the actuator has to be controlled in two different load pressures while keeping the actuator speed nearly constant.	A-51
"03" Pressure Compensator with Unloading Type			It is suitable for a situation where a long unloading time is required and heat generation and noise have to be kept at their lowest levels. <ul style="list-style-type: none">• The pump can be used in combination with the multistage pressure control valve.	A-59
"04" Proportional Electro-Hydraulic Load Sensing Type			This is an energy-saving type control which regulates the pump flow and load pressure to be at absolute minimum necessary level to operate the actuator. Pump flow rate and cut-off pressure are controlled proportional to the input current to the control device on the pump and the input current is regulated by the specific amplifier.	A-60
"04E" Electro-Hydraulic Proportional Pressure & Flow Control Type			This type of control has the pressure sensor and tilt angle sensor in the pump. The pump is used with the external amplifier (amplifier is integrated into pump in case of "04EH"). Flow and pressure can be controlled in proportion to input voltage by only one control valve. The features has been greatly improved by electrical feedback of swash plate tilt angle correspond to flow rate and load pressure to control valve.	A-70
"04EH" Electro-Hydraulic Proportional Pressure & Flow Control Type (OBE Type)			The features has been greatly improved by electrical feedback of swash plate tilt angle correspond to flow rate and load pressure to control valve. <ul style="list-style-type: none">• Linearity of input characteristics is excellent and easy to set.• Hysteresis is lower, repeatability and reproducibility are fine.	A-79
"05" Two-Pressure Two-Flow Control Type by System Pres.			This type of control is suitable for an application like "Presses" where the changeover from rapid advance to feed is required just when the pressing (pressurizing) starts.	A-88
"06" Two-Pressure Two-Flow Control Type by Solenoid Valve			This pump control is suitable for machining found on machine tool, where machining starts after the changeover from rapid advance to feed has been made.	A-89

Control Type

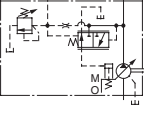
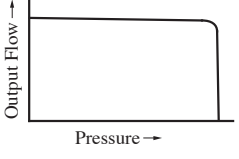
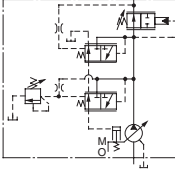
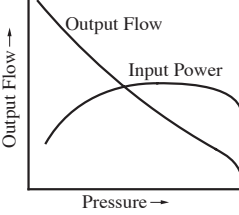
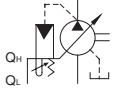
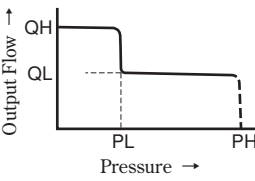
Control Type	Graphic Symbols	Performance Characteristics	Explanation	Page
"07" Pilot Pressure Control Type Pressure Compensator			The pump is used in combination with the pilot relief valve or multistage pressure control valve. By controlling the pilot pressure, the full cut-off pressure can be remote-controlled according to your requirements.	A-90
"09" Constant Power Control Type			<ul style="list-style-type: none"> • Pump input power can be controlled in accordance with the motor output. • When the discharge pressure rise, the output flow decreases corresponding to the preset input power. • The pump can act for function of two pumps, low-pressure large-flow and high-pressure small-flow. Therefore, the motor capacity can be reduced. 	A-98
"00-Z500" Simple Two-Pressure Two-Flow Control Type			<ul style="list-style-type: none"> • This type of control enables one pump to act as two pumps (low-pressure and large-flow/high-pressure and small-flow-rate). Therefore, the motor capacity can be reduced. • When the system pressure increases near the preset "PL" pressure due to the load increase, the pump flow automatically decreases to "QL." • This type of control is suitable for an application like the press, where switching from rapid advance to feed is required just when the press (pressurizing) starts. • The PH pressure can be remote-controlled with a separately located relief valve. With this type of control, it is easy to change the applied pressure setting when materials or shapes of the press are changed. 	A-106

Availability of Control Type

Mark "○" in the table below refers to standard model.

Model Numbers	Geometric Displacement cm ³ /rev	Control Type										
		01	02	03	04	04E	04EH	05	06	07	09	00-Z500
A10	10.0	○								○		
A16	15.8	○	○	○	○	○	○	○	○	○	○	○
A22	22.2	○	○	○	○	○	○		○	○		
A37	36.9	○	○	○	○	○	○	○	○	○	○	○
A45	45.0	○					○					
A56	56.2	○	○	○	○	○	○	○	○	○	○	○
A70	70.0	○	○	○	○	○	○		○	○	○	○
A90	91.0	○	○	○	○	○	○		○	○		○
A100	100	○			○	○						
A145	145	○	○	○	○	○	○		○	○	○	○

Series Variable Displacement Piston Pumps, Pressure Compensator Type

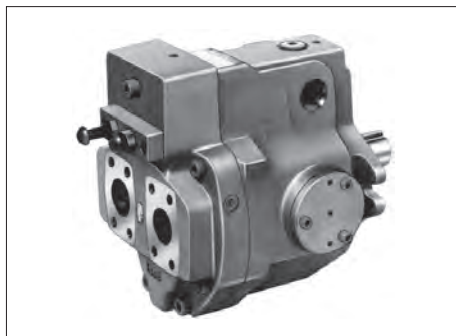

Graphic Symbol

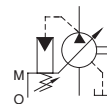

Specifications

Model Numbers	Geometric Displacement cm ³ /rev	Minimum Adj. Flow cm ³ /rev	Operating Pressure MPa		Shaft Speed Range r/min		Approx. Mass kg	
			Rated ^{★2}	Intermittent ^{★1}	Max.	Min.	Flange Mtg.	Foot Mtg.
A10-FR01 *-13	10.0	2	16	21	1800	600	8.5	—
A16- *-R-01- *- *-K-32	15.8	4	16	21	1800	600	16.5	18.7
A22- *-R-01- *- *-K-32	22.2	6	16	16	1800	600	16.5	18.7
A37- *-R-01- *- *-K-32	36.9	10	16	21	1800	600	Axial:23.2 Side:28	Axial:26.3 Side:31.1
A45- *-R-01- *- *-K-10	45.0	10	16	16	1800	600	28	32.3
A56- *-R-01- *- *-K-32	56.2	12	16	21	1800	600	Axial:30.8 Side:35	Axial:33.3 Side:38.1
A70- *R01 *S-70	70.0	36	25	28	1800	600	55.5	67.5
A90- *R01 *S-70	91.0	56	25	28	1800	600	72	87.5
A100- *R01 *S-20	100	62	21	21	1800	600	72.5	88
A145- *R01 *S-60	145	83	25	28	1800	600	92.5	117.7

- ★1. Whenever setting pressure, make sure the full cut-off pressure never exceeds the maximum intermittent pressure.
- ★2. Care should be taken in cases of used at a higher pressure than the rated pressure, because operating terms may be restricted. For example, if used as per maximum illustrated operating conditions, intermittent time at maximum flow is restricted to under 1/5 of one cycle time and under six seconds simultaneously. Conditions may vary according to the actual working pressure and delivery (inclination angle of the swash plate). Consult factory or Yuken sales representative for further information.
- ★3. The table above shows specifications for using petroleum based oils. Pumps (customized design) for special fluids are also available. Their operating pressure and maximum shaft speed however differ from the values in the table above depending on the fluid type. Range of operating temperature and viscosities may differ from those of petroleum based oils due to their characteristics. Refer to the table below for details.

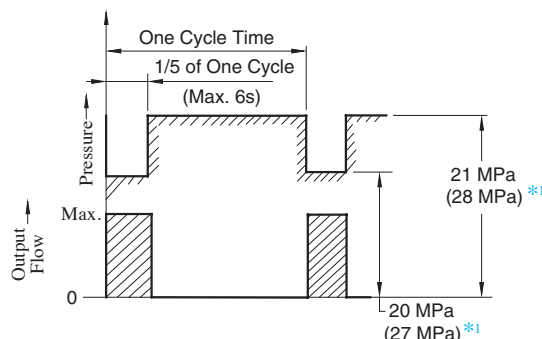

*1. Applicable only for "A70/90/145"

Specifications and Design numbers for Special Fluids

Type of Fluids	Pump Series	Operating Pressure MPa		Allowable Maximum Shaft Speed r/min		Temperature Range °C	Viscosity Range mm ² /s	Design Numbers for Special Fluid
		Rated	Intermittent	Rated	Max.			
Water-Glycols	A16,A22,A37,A56	14	16 (14) ^{★1}	1200	(1800) ^{★2}	0-50	20-200	3230
	A70,A90,A145	21	21					7030 [A70, A90] 6030 [A145]
	A100	16	16					2006
Phosphate Ester Type	A16,A22,A37,A56	14	16 (14) ^{★1}	1200	(1800) ^{★2}	0-60	20-200	3206
	A70,A90,A145	21	21					7006 [A70, A90] 6006 [A145]
	A100	21	21					2030
Polyol Ester Type	A16,A22,A37,A56	16	16	1800	1800	0-60	20-200	32450
	A70,A90,A145	21	21					70450 [A70, A90] 60450 [A145]
	A100	21	21					20450

- ★1. The figures in brackets are for A22 type.
- ★2. As the specific gravities of water-glycol fluids and phosphate ester type fluids are higher than one, an overhead reservoir is required when pumps are operated at 1400 r/min or more.

Model Number Designation

A16	-F	-R	-01	-B	-S	-K	-32
Series Number	Mounting	Direction of Rotation	Control Type	Pres. Adj. Range MPa	Port Position	Shaft Extension	Design Number
A16 (15.8 cm ³ /rev)	F: Flange Mtg. L: Foot Mtg.	(Viewed from Shaft End) R: Clockwise* ² (Normal)	01: Pressure Compensator Type	B: 1.2 - 7 C: 1.2 - 16 H: 1.2 - 21	None: Axial Port S: Side Port	K: Keyed Shaft	32
A22 (22.2 cm ³ /rev)				B: 1.2 - 7 C: 1.2 - 16			32
A37 (36.9 cm ³ /rev)				B: 1.2 - 7 * ³ C: 1.2 - 16 H: 1.2 - 21			32
A45 (45.0 cm ³ /rev)							10
A56 (56.2 cm ³ /rev)							32

A70	-F	R	01	B	S	-70
Series Number	Mounting	Direction of Rotation	Control Type	Pres. Adj. Range MPa	Port Position	Design Number
A10 (10.0 cm ³ /rev)	F: Flange* ¹ Mtg.	(Viewed from Shaft End) R: Clockwise* ² (Normal)	01: Pressure Compensator Type	B: 1.2 - 7 C: 2.0 - 16 H: 2.0 - 21	—	13
A70 (70.0 cm ³ /rev)	F: Flange Mtg. L: Foot Mtg.			B: 1.2 - 7 * ⁴ C: 1.5 - 16 H: 1.8 - 21 K: 2.0 - 28	S: Side Port	70
A90 (91.0 cm ³ /rev)						70
A100 (100 cm ³ /rev)						20
A145 (145 cm ³ /rev)						60

★ 1. When A10 pump is used as the foot Mtg., order the Mtg. bracket kit shown below separately. Refer to page A-17 for dimensions of the Mtg. bracket.

Note: The mounting bracket kit consists of a mounting bracket, two hex. bolts and two plain washer.

Mtg. Bracket Kit Numbers	Approx. Mass kg
LP-1A-10	2.2

★ 2. Available to supply pump with anti-clockwise rotation (except A100). Consult Yuken for details.

★ 3. Pres. adj. range of A45 type is B and C

★ 4. Pres. adj. range of A100 type is B, C, and H.

Pipe Flange Kits

Pipe flange kits are available. When ordering, specify the kit number from the table below.

Pump Model Numbers	Name of Port	Pipe Flange Kit Numbers		
		Threaded Connection	Socket Welding* ⁴	Butt Welding
A16- * -R-01	Suction	F5-06-A-10	F5-06-B-10	F5-06-C-10
A22- * -R-01	Discharge	F5-06-A-10	F5-06-B-10	F5-06-C-10
A37- * -R-01	Suction	F5-10-A-10	F5-10-B-10	F5-10-C-10
A45- * -R-01	Discharge	F5-10-A-10	F5-10-B-10	F5-10-C-10
A56- * -R-01				
A70- * R01	Suction	F5-12-A-10	F5-12-B-10	F5-12-C-10
	Discharge	F5-08-A-10	F5-08-B-10	F5-08-C-10
A90- * R01	Suction	F5-16-A-10	F5-16-B-10	F5-16-C-10
A100- * R01	Discharge	F5-10-A-10	F5-10-B-10	F5-10-C-10
A145- * R01				

★ In case of using socket welding flanges, there is a case where the operating pressure should be set lower than the normal because of strength of the flanges. Therefore, please pay cautious attention to the operating pressure when the socket welding flanges are used.

● Details of the pipe flange kits are shown on pages A-258 and A-259.

Response Characteristics Change in Accordance with Circuits and Operating Conditions.

The Circuit and Conditions

Circuit

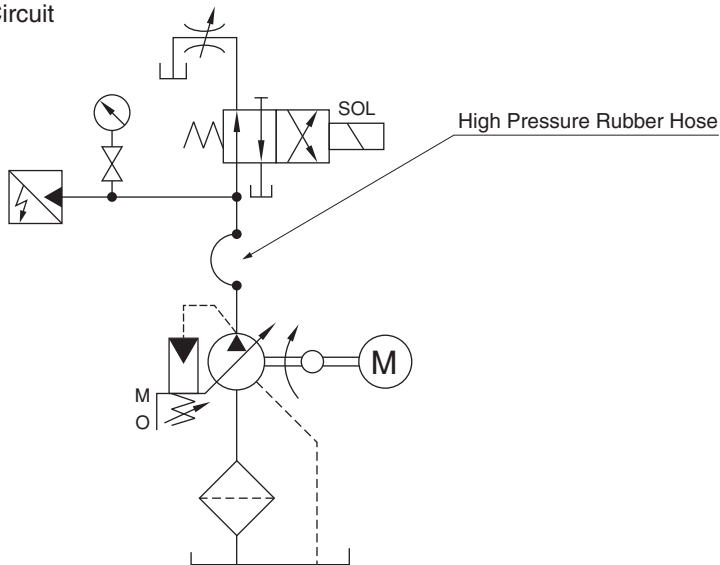

Model	Rubber Hose Size
A10	1/2"× 800 mm
A16 A22	3/4"× 700 mm
A37 A56	3/4"× 2000 mm
A70	3/4"× 3500 mm
A90 A100 A145	3/4"× 3000 mm + 1-1/4 × 2000 mm

Conditions

Shaft Speed : 1500 r/min
 Hydraulic Fluid : ISO VG 32 Oil
 Oil Temperature: See right table

Model	Oil Temperature
A10 - A56	50°C (20 mm ² /s)
A70 - A145	40°C (32 mm ² /s)

Result of Measurement

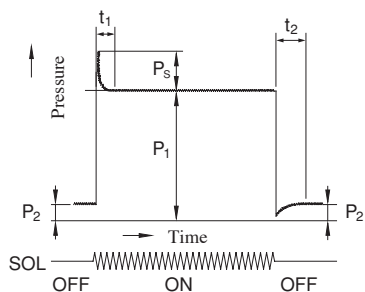

Model	Full Cut-off Pressure P ₁ MPa	Pressure at Full Flow P ₂ MPa	Response Time ms		Overshoot Pressure P _s MPa
			t ₁	t ₂	
A10	21	2	100	75	2.6
A16	16	2	38★	59★	3.6
A22	16	2	30★	72★	5.9
A37	16	2	40★	78★	7.8
A56	16	2	38★	88★	7.6
A70	25	2	80	100	7.8
A90	25	3	90	110	7.9
A100	21	3	90	110	8.1
A145	25	3	100	150	8.8

★ 1. Response time except A16, A22, A37 and A56 is measured Yoke travel.
 ★ 2. As for A45, please contact us.

Typical Performance Characteristics of Type **A10** at Viscosity 20 mm²/s [ISO VG32 Oils, 50°C]

Performance Characteristic Curve

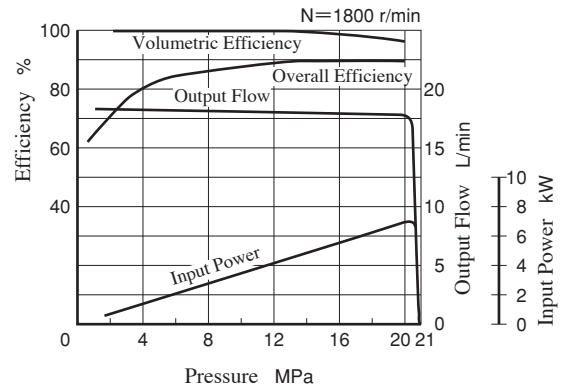
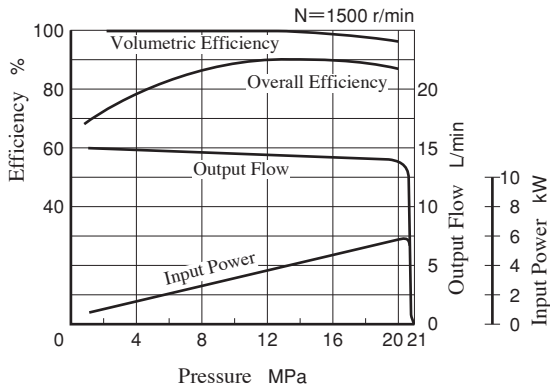

Input Power

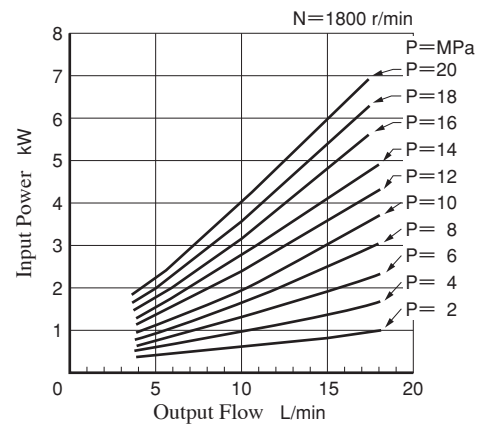
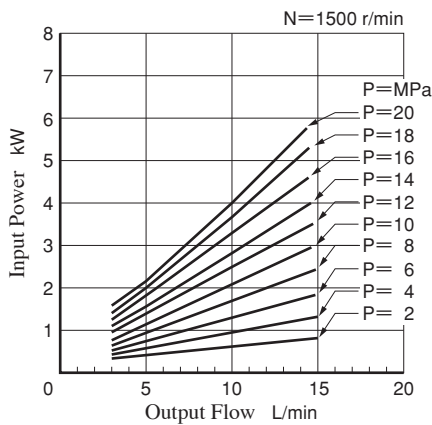

Full Cut-off Power

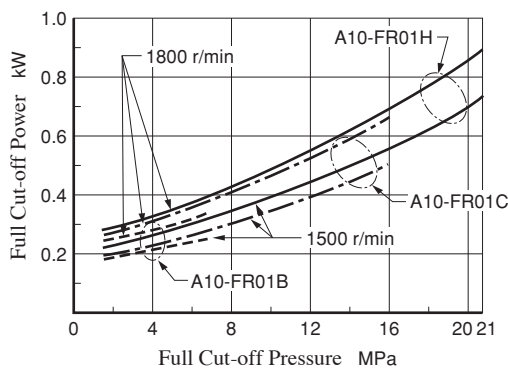

Drain

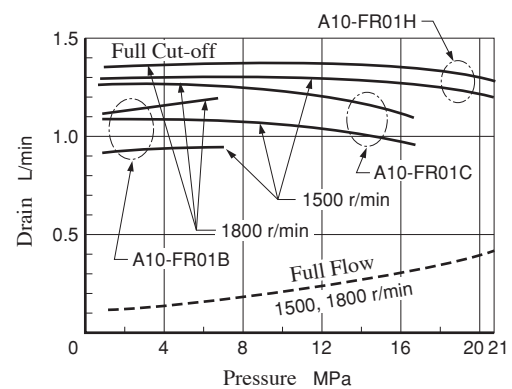

Noise Level [One meter horizontally away from pump head cover]

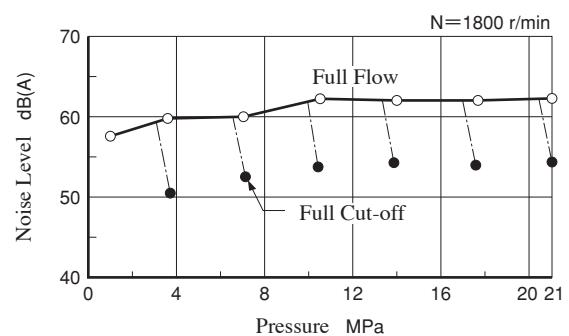
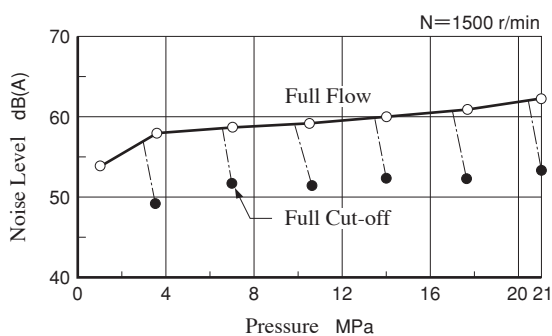

Typical Performance Characteristics of Type **A16** at Viscosity 20 mm²/s [ISO VG32 Oils, 50°C]

Performance Characteristic Curve

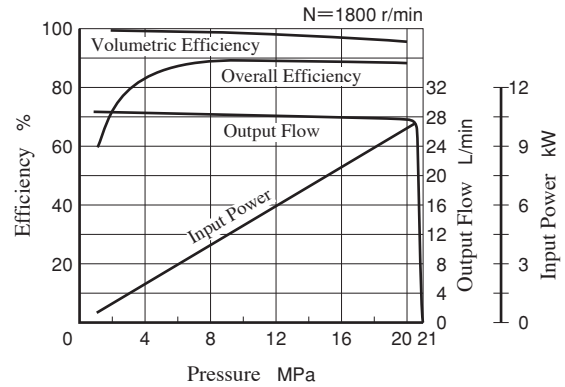
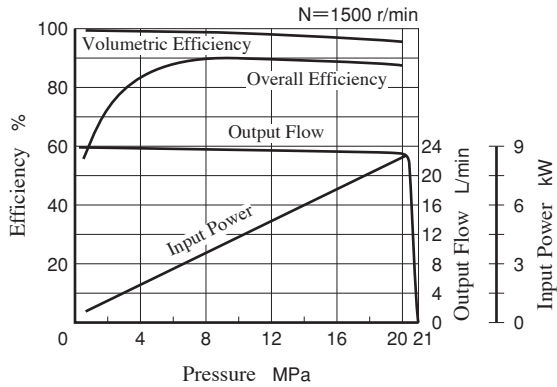

Input Power

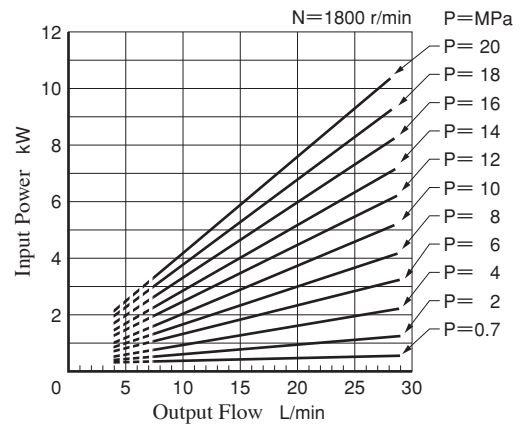
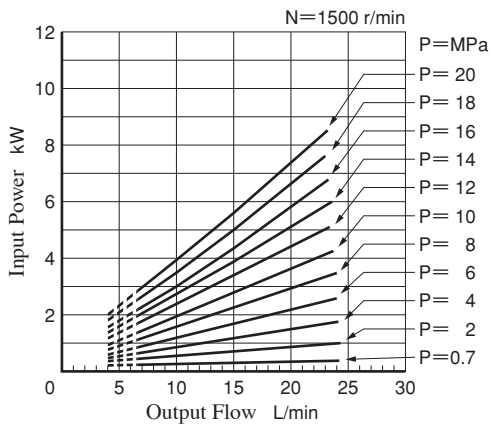

Full Cut-off Power

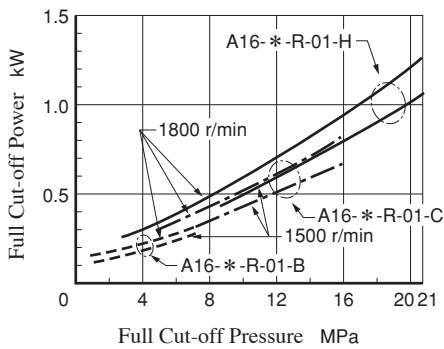

Drain

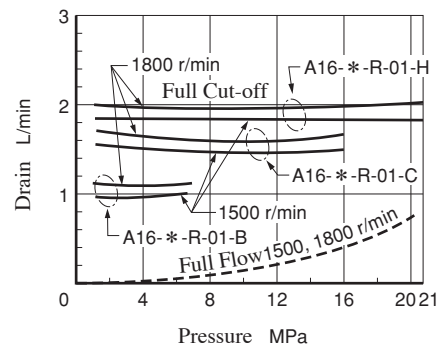

Noise Level [One meter horizontally away from pump head cover]

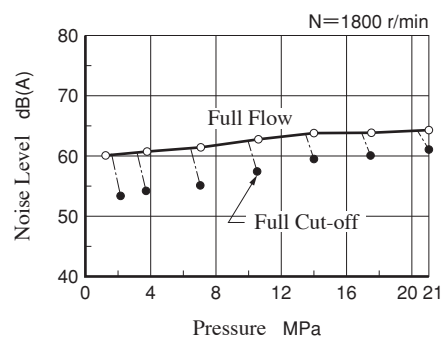
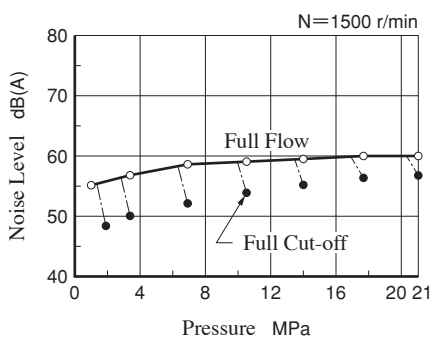

Typical Performance Characteristics of Type **A22** at Viscosity 20 mm²/s [ISO VG32 Oils, 50°C]

Performance Characteristic Curve

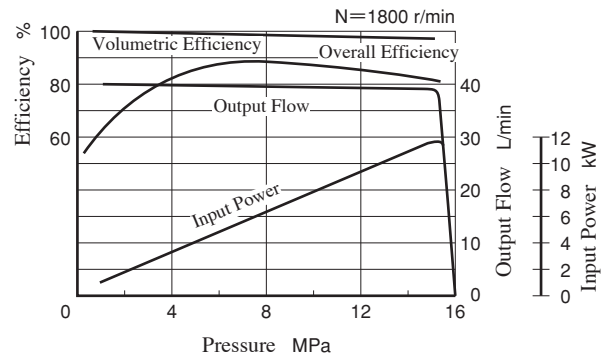
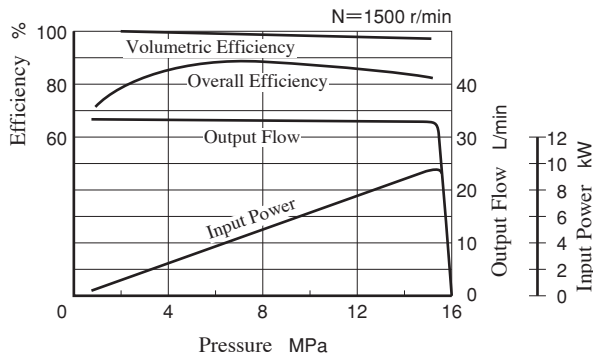

Input Power

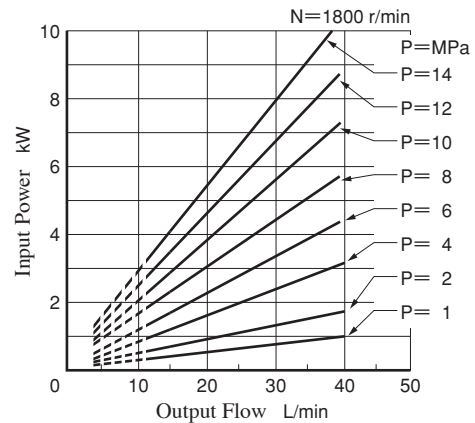
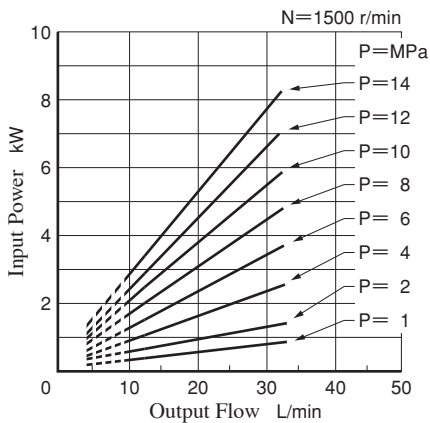

Full Cut-off Power

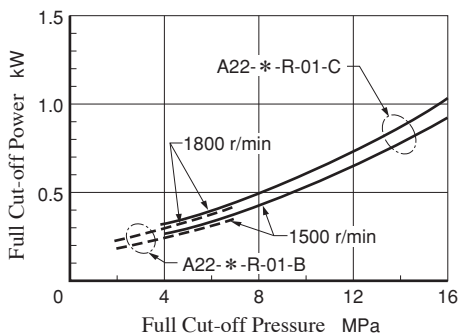

Drain

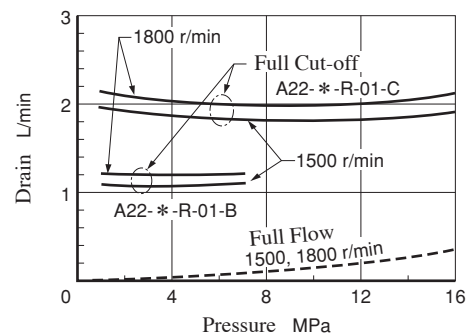

Noise Level [One meter horizontally away from pump head cover]

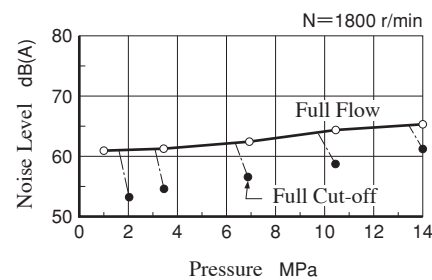
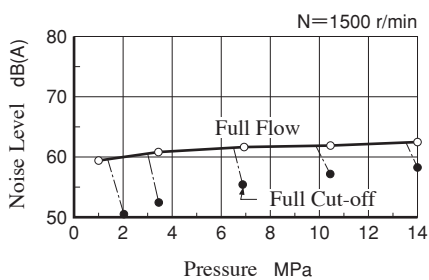

Typical Performance Characteristics of Type **A37** at Viscosity 20 mm²/s [ISO VG32 Oils, 50°C]

Performance Characteristic Curve

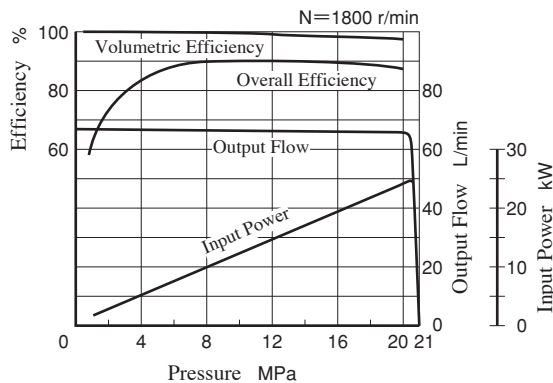
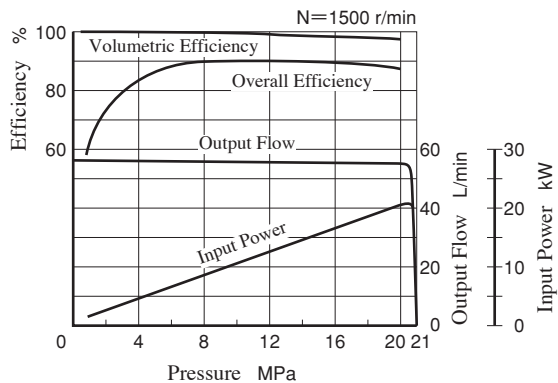

Input Power

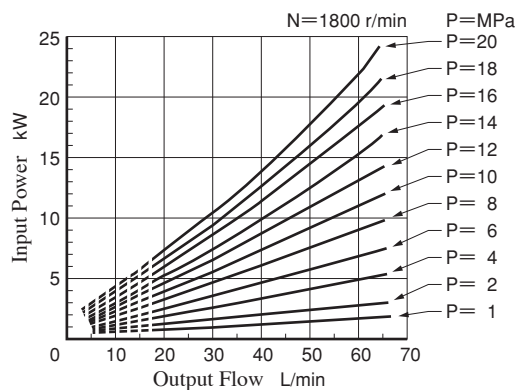
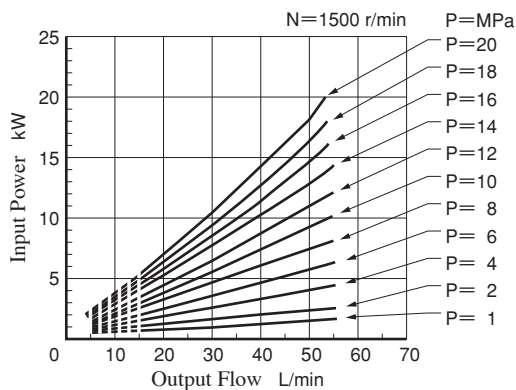

Full Cut-off Power

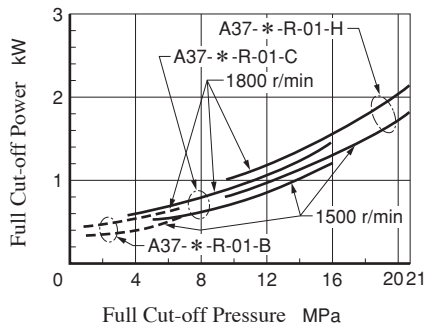

Drain

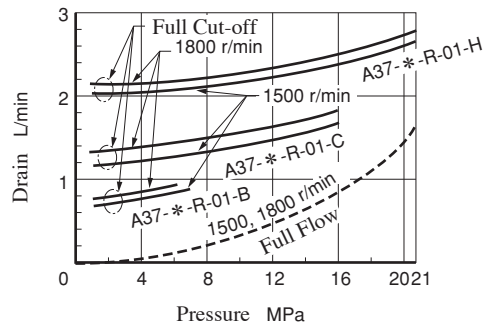

Noise Level [One meter horizontally away from pump head cover]

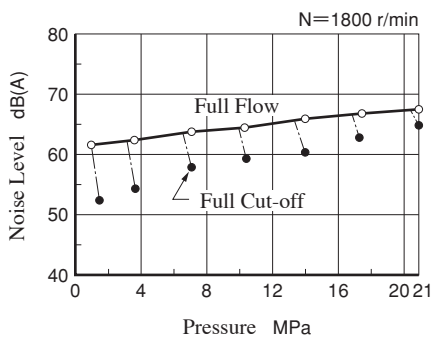
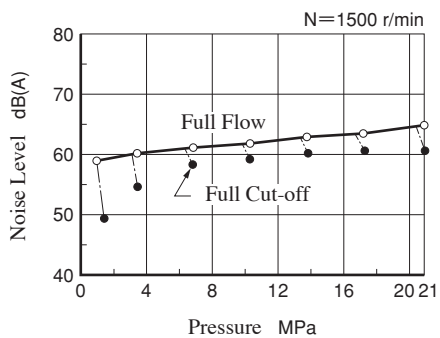

Typical Performance Characteristics of Type **A45** at Viscosity 32 mm²/s [ISO VG32 Oils, 40°C]

Performance Characteristic Curve

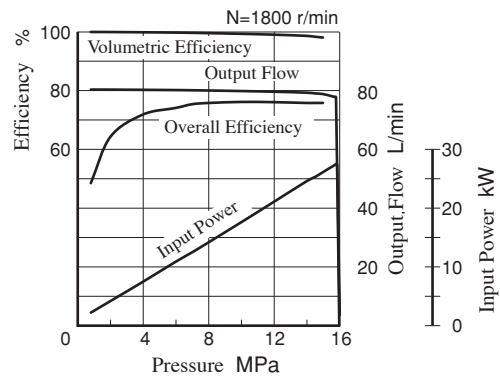
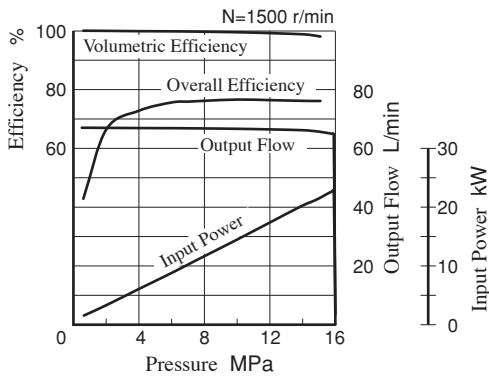

Input Power

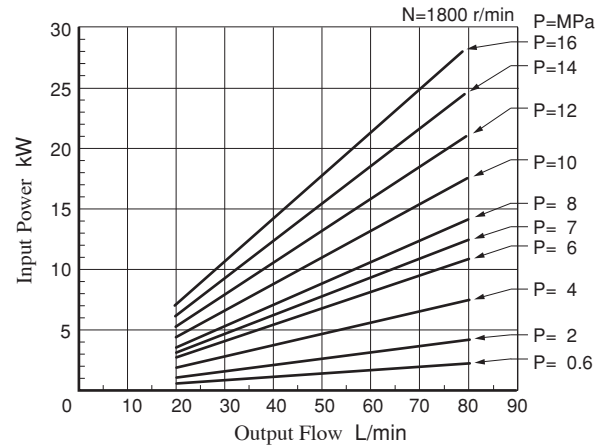
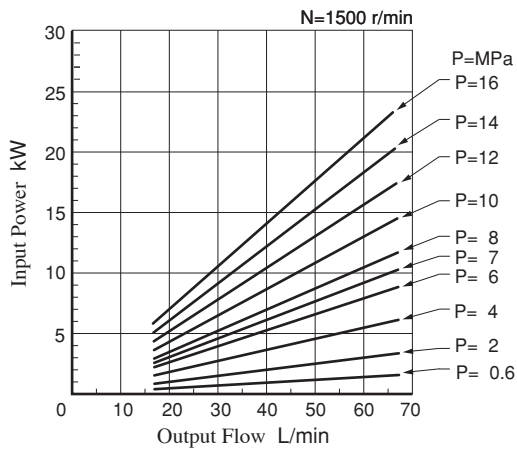

Full Cut-off Power

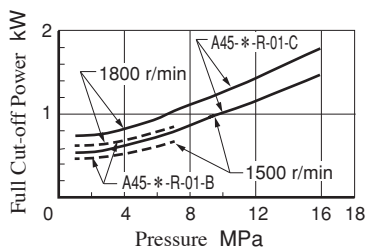

Drain

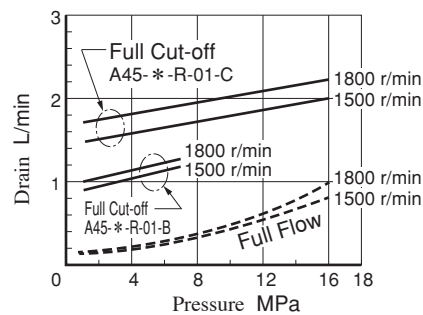

Noise Level [One meter horizontally away from pump head cover]

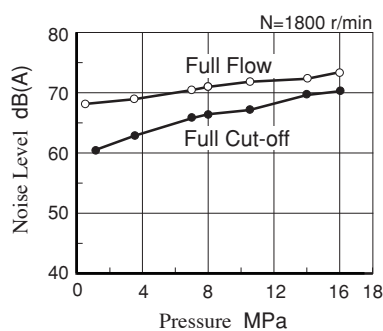
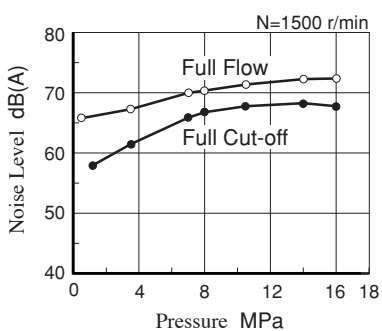

Typical Performance Characteristics of Type **A56** at Viscosity 20 mm²/s [ISO VG32 Oils, 50°C]

Performance Characteristic Curve

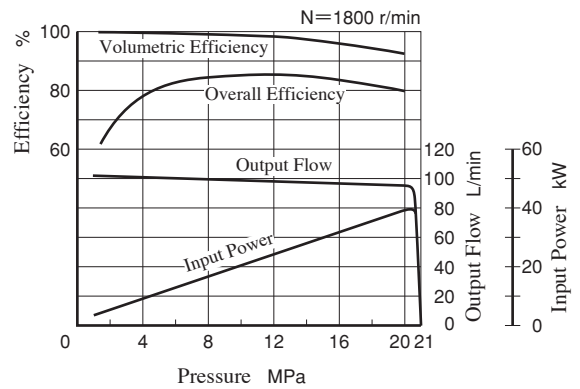
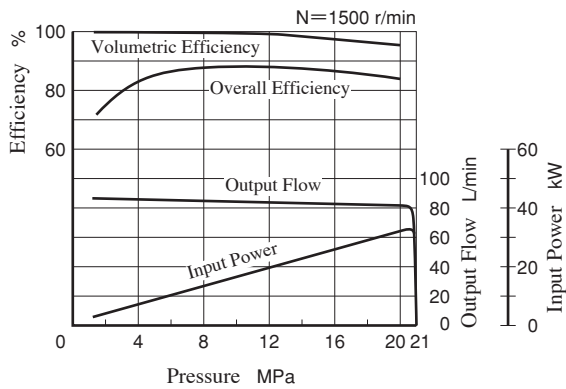

Input Power

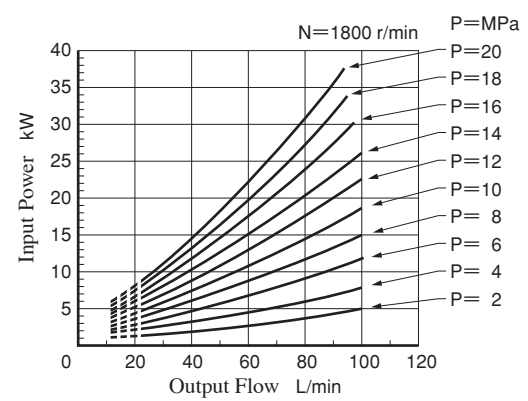
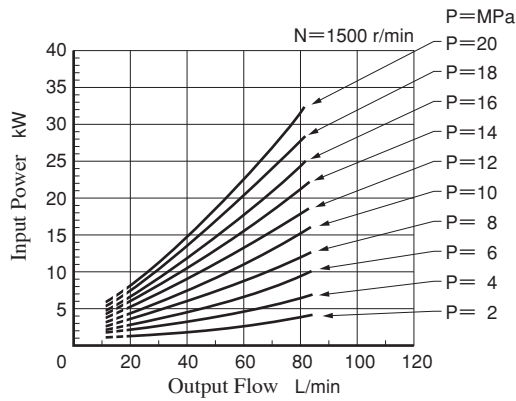

Full Cut-off Power

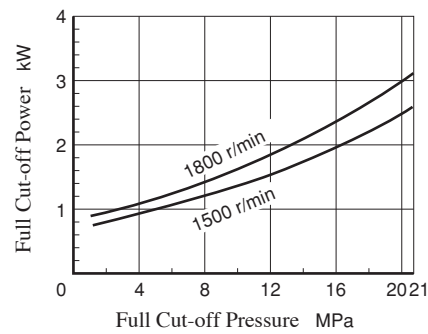

Drain

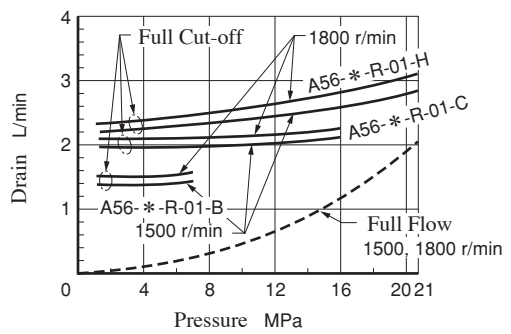

Noise Level [One meter horizontally away from pump head cover]

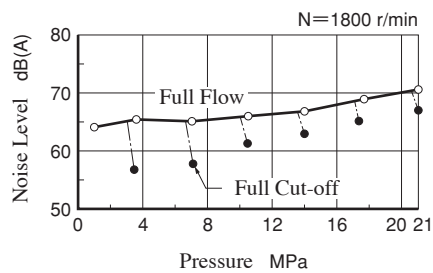
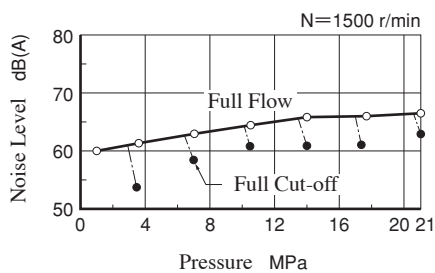

Typical Performance Characteristics of Type **A70** at Viscosity 20 mm²/s [ISO VG32 Oils, 50°C]

Performance Characteristic Curve

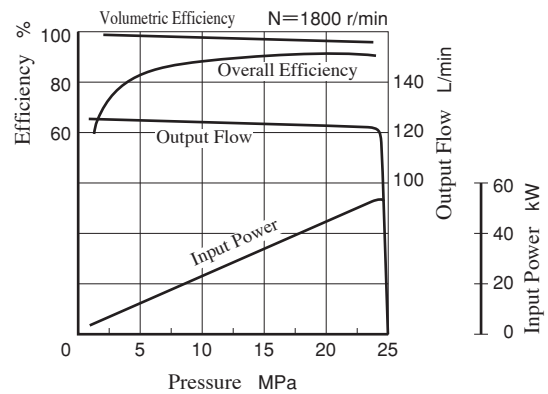
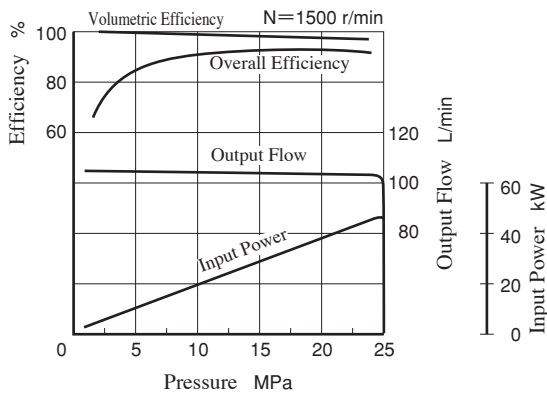

Input Power

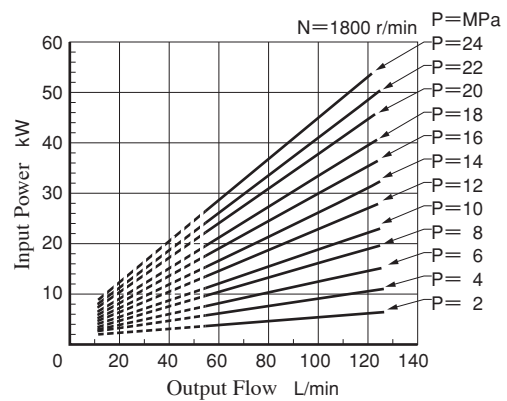
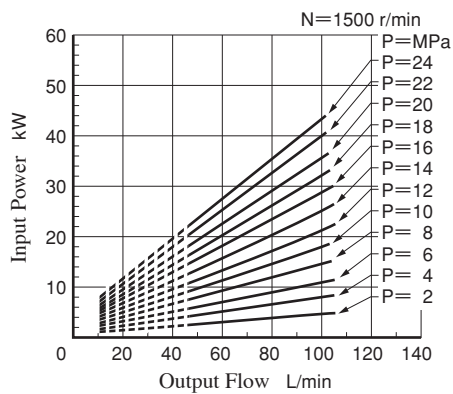

Full Cut-off Power

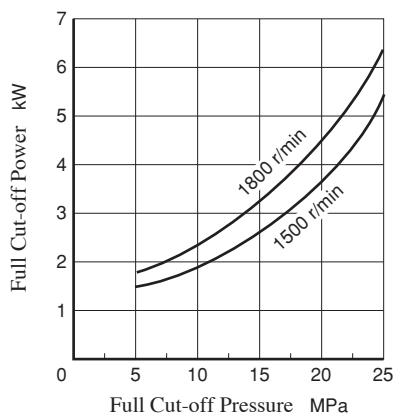

Drain

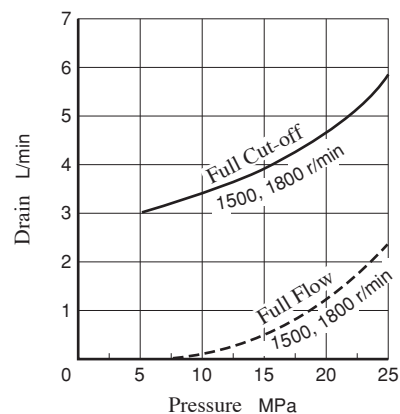

Noise Level [One meter horizontally away from pump head cover]

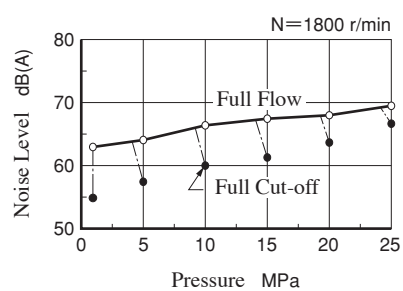
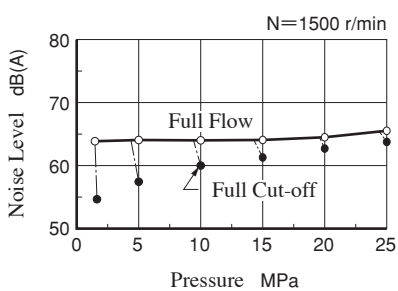

Typical Performance Characteristics of Type **A90** at Viscosity 20 mm²/s [ISO VG32 Oils, 50°C]

Performance Characteristic Curve

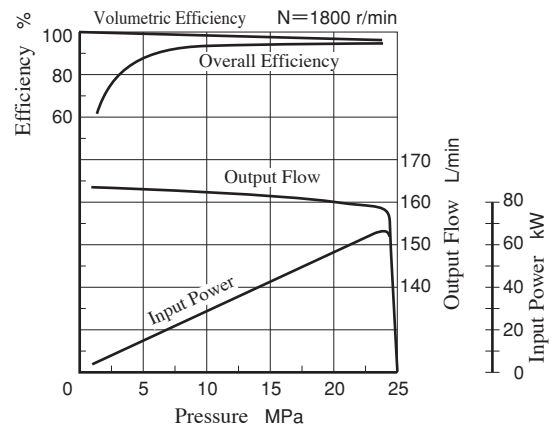
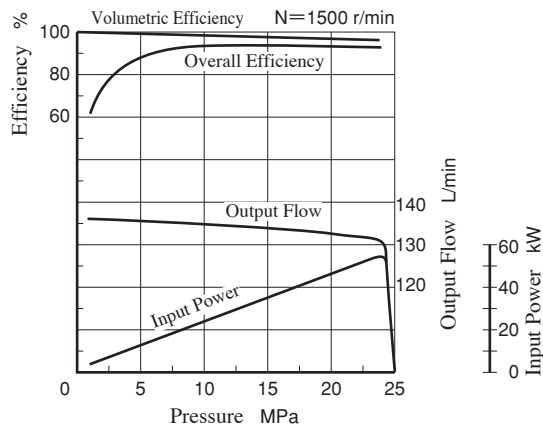

Input Power

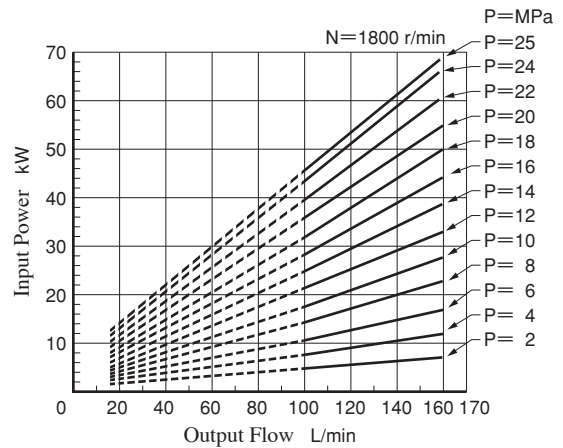
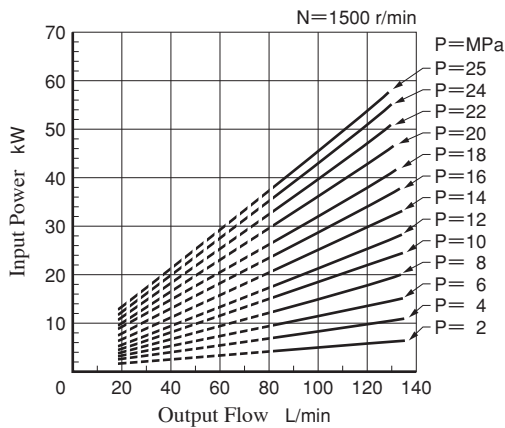

Full Cut-off Power

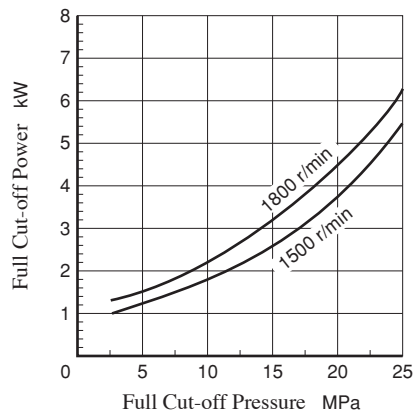

Drain

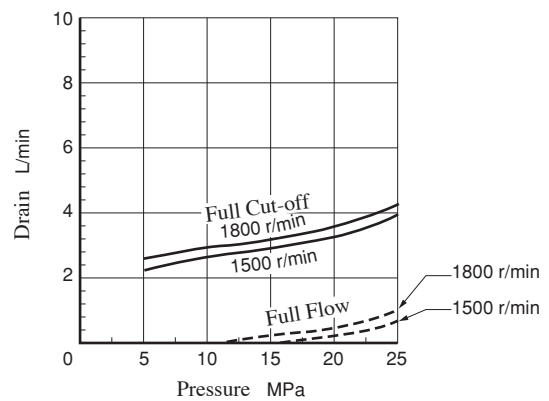

Noise Level [One meter horizontally away from pump head cover]

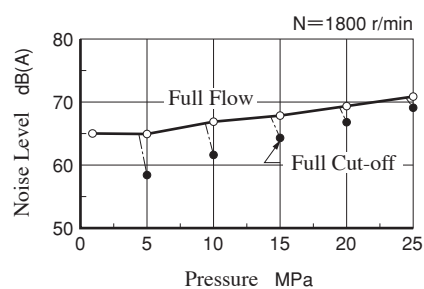
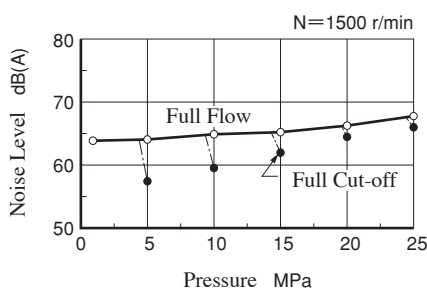

Typical Performance Characteristics of Type A100 at Viscosity 20 mm²/s [ISO VG32 Oils, 50°C]

Performance Characteristic Curve

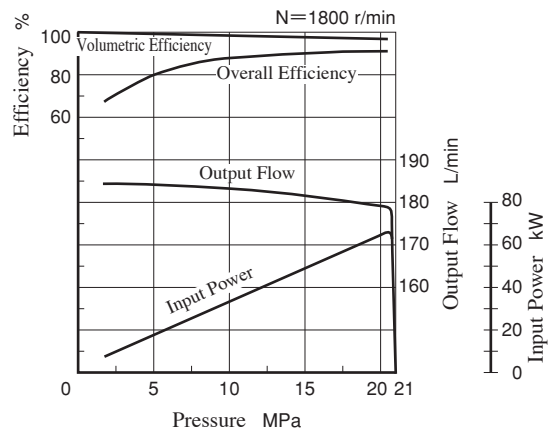
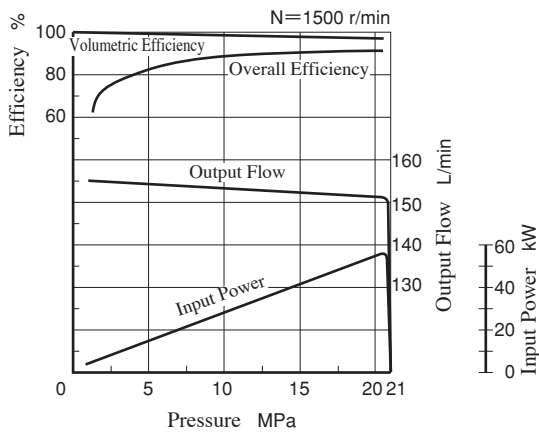

Input Power

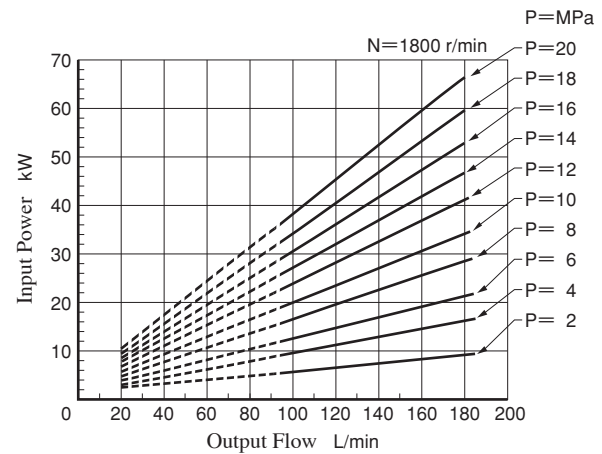
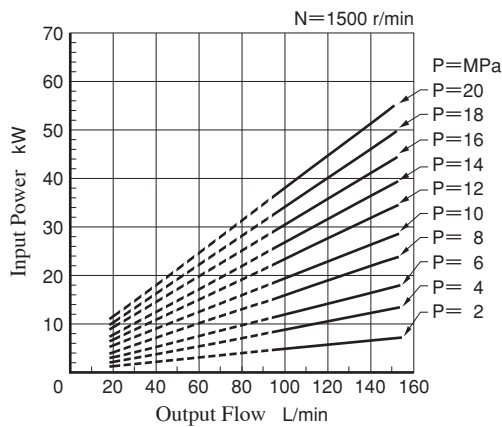

Full Cut-off Power

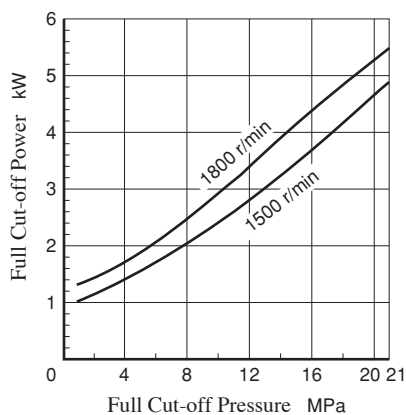

Drain

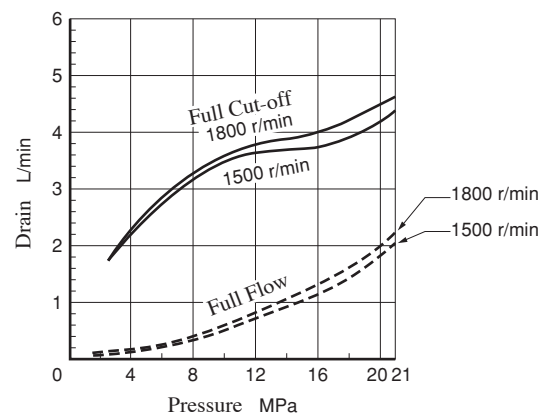

Noise Level [One meter horizontally away from pump head cover]

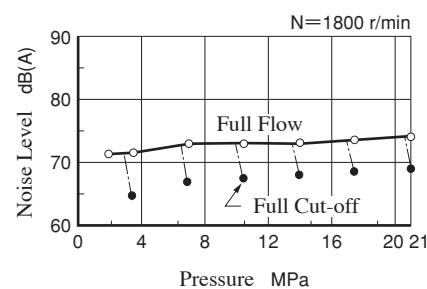
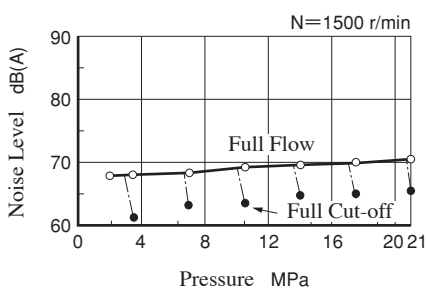

Typical Performance Characteristics of Type **A145** at Viscosity 20 mm²/s [ISO VG32 Oils, 50°C]

Performance Characteristic Curve

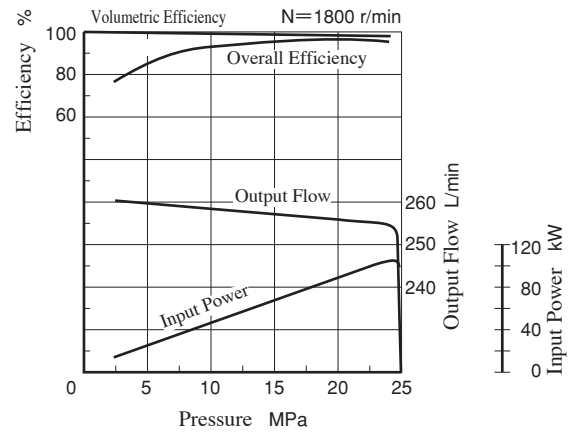
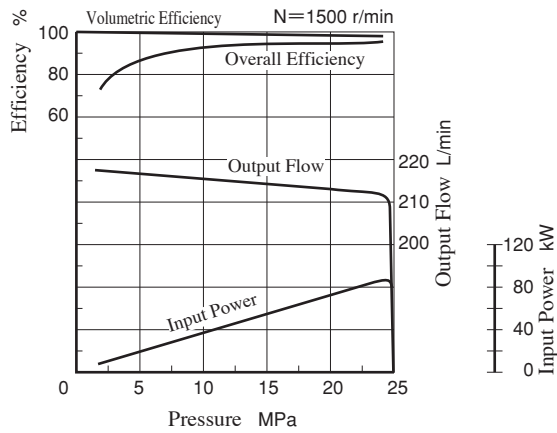

Input Power

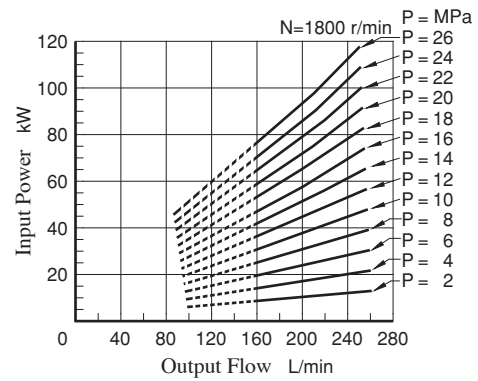
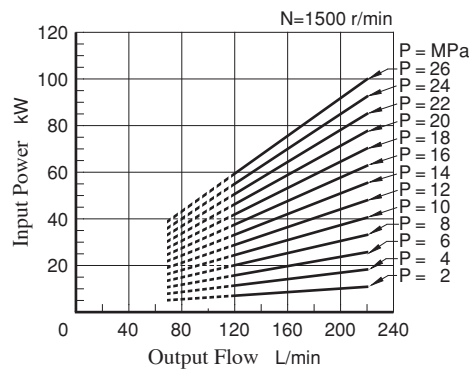

Full Cut-off Power

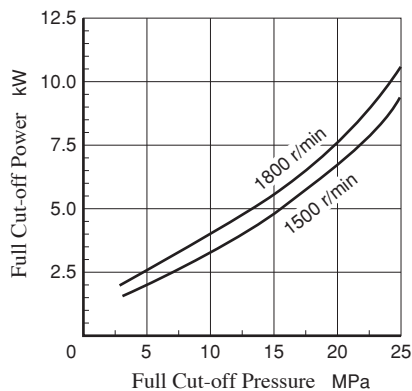

Drain

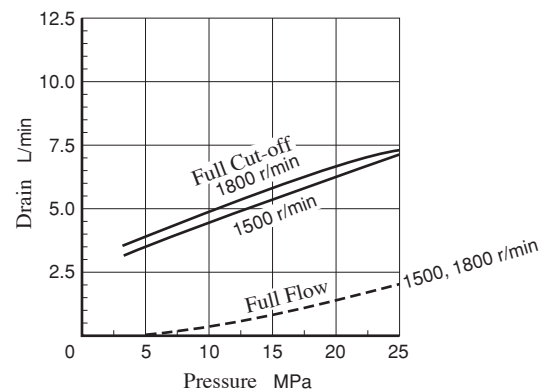

Noise Level [One meter horizontally away from pump head cover]

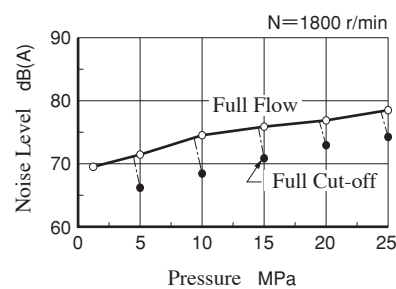
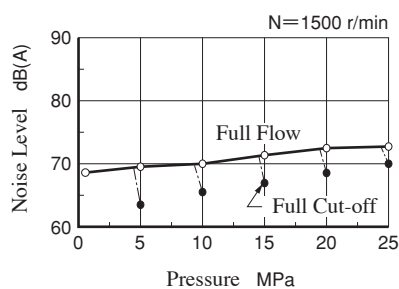

Flange Mtg. : A10-FR01 *

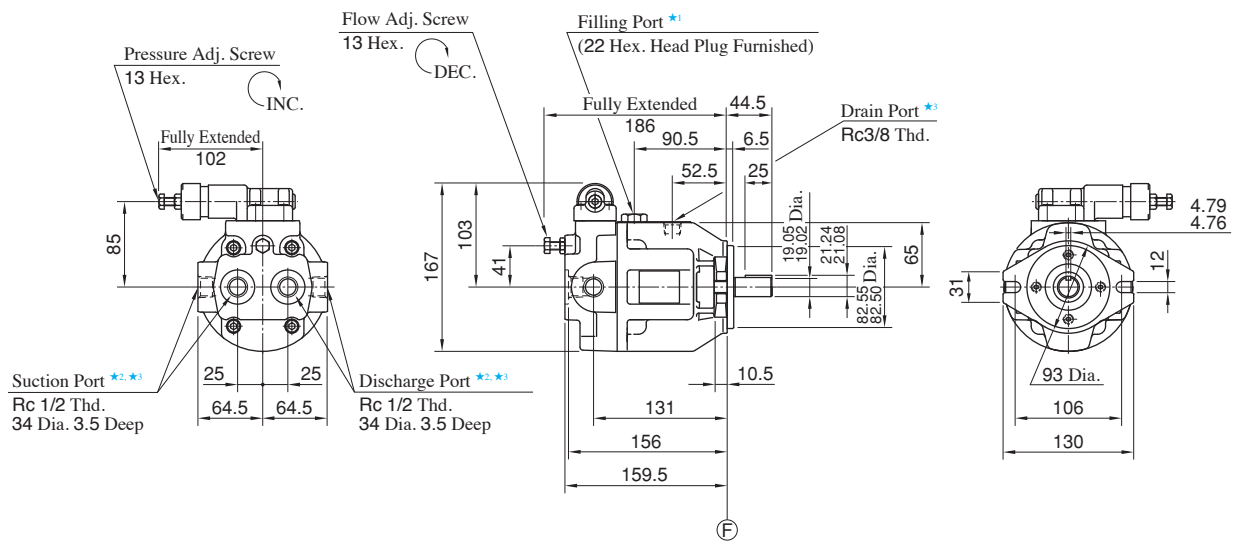

- ★1. Install the pump so that the "Filling Port" is at the top.
- ★2. Use either port of two suction and discharge ports at your option. Keep the remaining ports plugged.
- ★3. As the tightening torques of suction, discharge and drain port fittings, conform to the below.

Name of Port	Tightening Torque Nm
Suction	65 - 75
Discharge	
Drain	40 - 50

Axial Port Type

**Flange Mtg. : A16-F-R-01- *-K
A22-F-R-01- *-K**

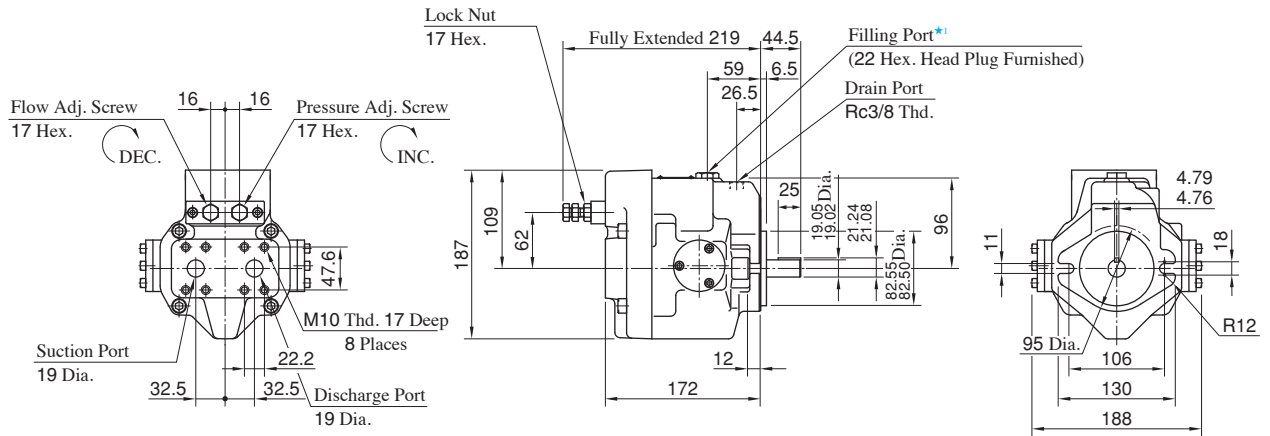

★ 1. Install the pump so that the “Filling Port” is at the top.

**Foot Mtg. : A16-L-R-01- *-K
A22-L-R-01- *-K**

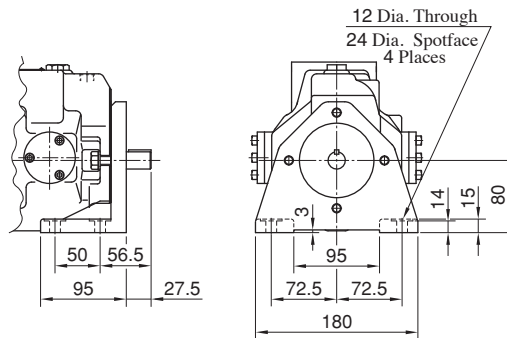

● For other dimensions, refer to “Flange Mtg.”.

Side Port Type

**Flange Mtg. : A16-F-R-01- *-S-K
A22-F-R-01- *-S-K**

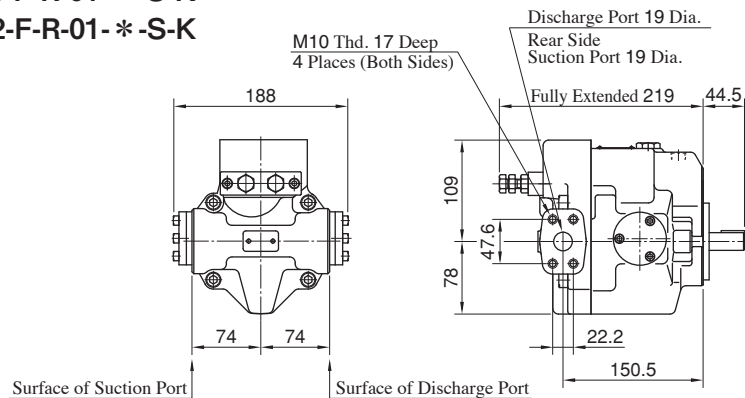

● For other dimensions, refer to “Axial Port Type”.

● Foot Mtg. Type : Mounting bracket is common to that of “Axial Port Type”.

Axial Port Type

**Flange Mtg. : A37-F-R-01- *-K
A45-F-R-01- *-K**

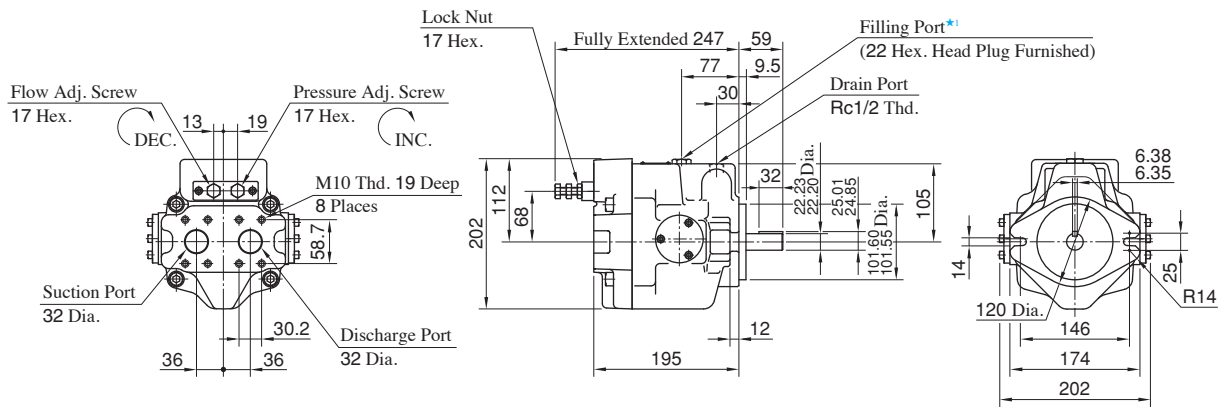

★ 1. Install the pump so that the “Filling Port” is at the top.

**Foot Mtg. : A37-L-R-01- *-K
A45-L-R-01- *-K**

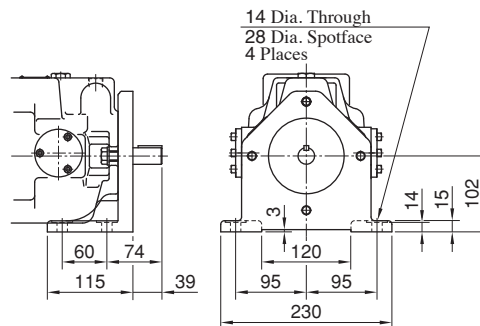

● For other dimensions, refer to “Flange Mtg.”.

Side Port Type

**Flange Mtg. : A37-F-R-01- *-S-K
A45-F-R-01- *-S-K**

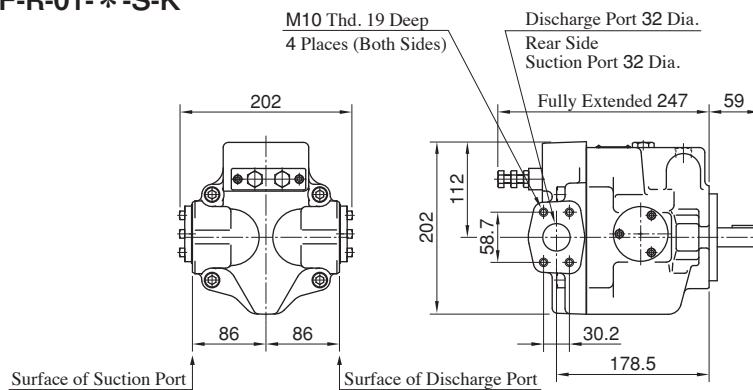

● For other dimensions, refer to “Axial Port Type”.

● Foot Mtg. Type : Mounting bracket is common to that of “Axial Port Type”.

Axial Port Type

Flange Mtg. : A56-F-R-01- *-K

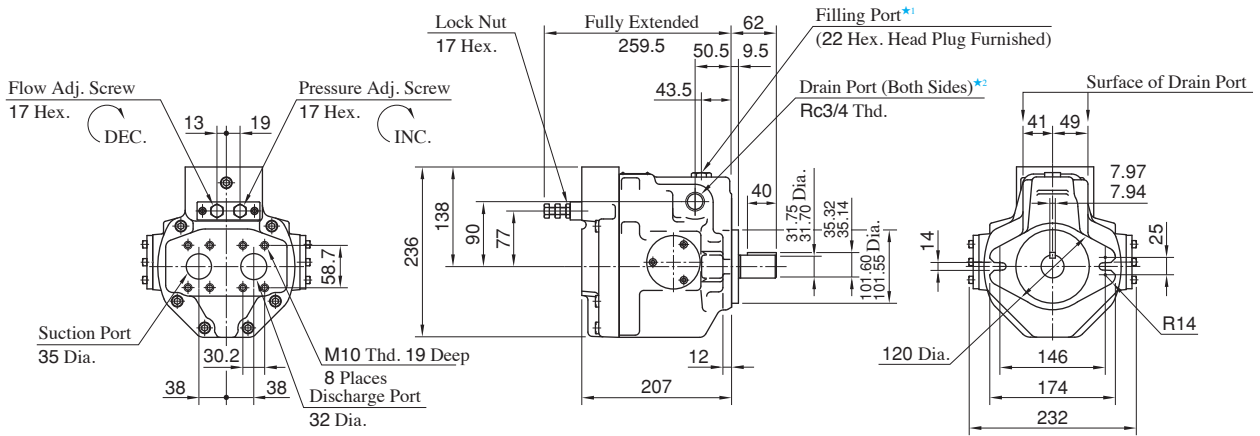

- ★ 1. Install the pump so that the “Filling Port” is at the top.
- ★ 2. Use either port of the two drain ports at your option. Keep the remaining port plugged.

Foot Mtg. : A56-L-R-01- *-K

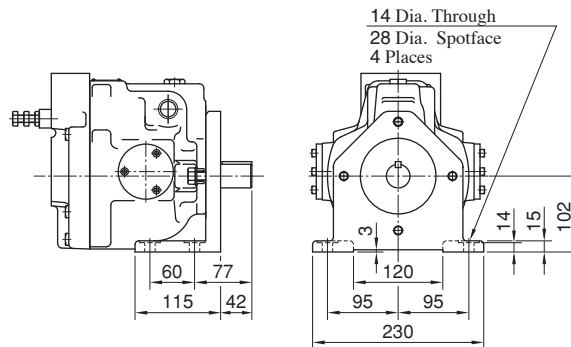

● For other dimensions, refer to “Flange Mtg.”.

Side Port Type

Flange Mtg. : A56-F-R-01- *-S-K

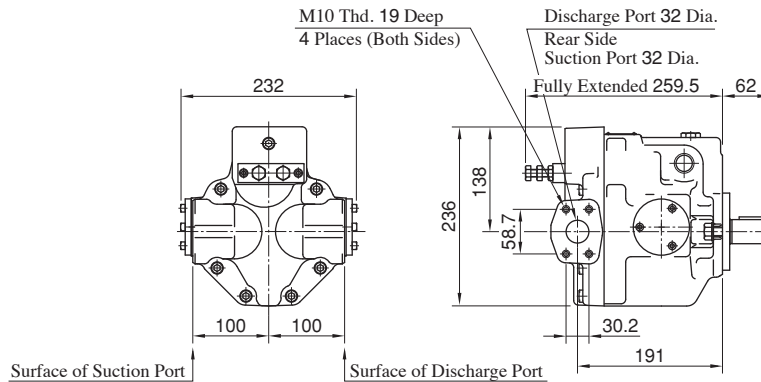

● For other dimensions, refer to “Axial Port Type”.

Side Port Type

Flange Mtg. : A70-FR01 * S

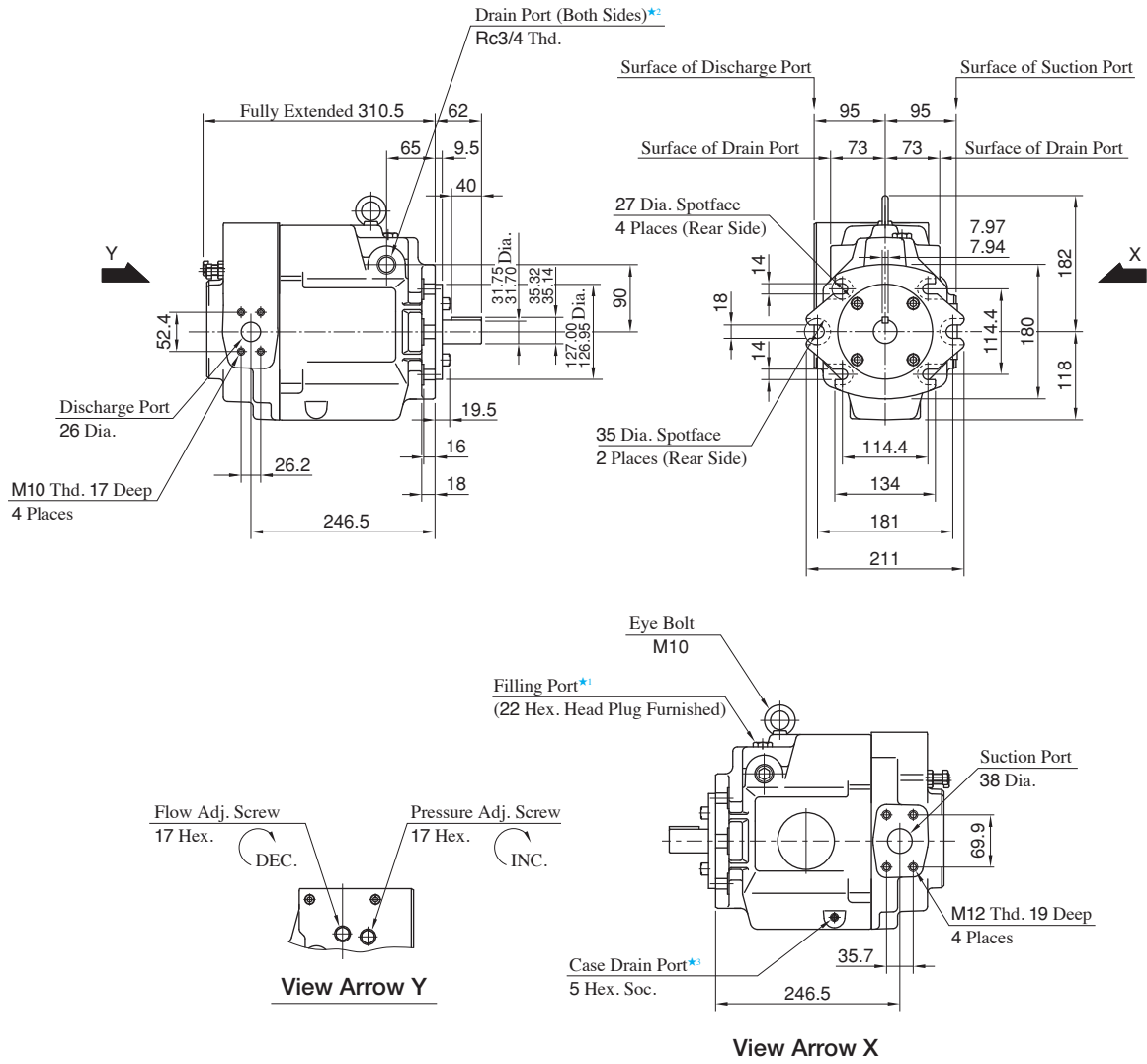

- ★1. Install the pump so that the "Filling Port" is at the top.
- ★2. Use either port of the two drain ports at your option. Keep the remaining port plugged.
- ★3. Case drain port is available for use when draining hydraulic fluid from pump casing.

Foot Mtg. : A70-LR01 * S

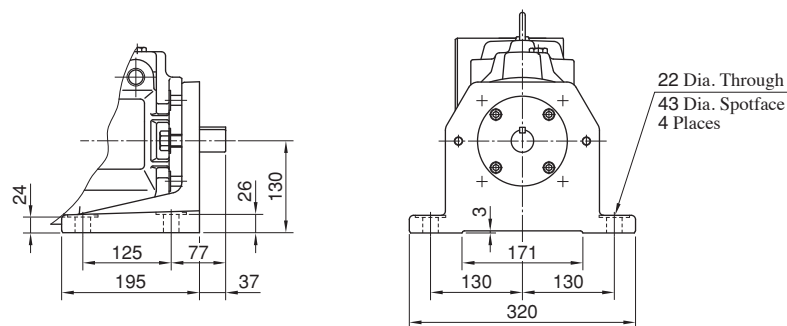

● For other dimensions, refer to "Flange Mtg."

Side Port Type

**Flange Mtg. : A90-FR01 * S
A100-FR01 * S**

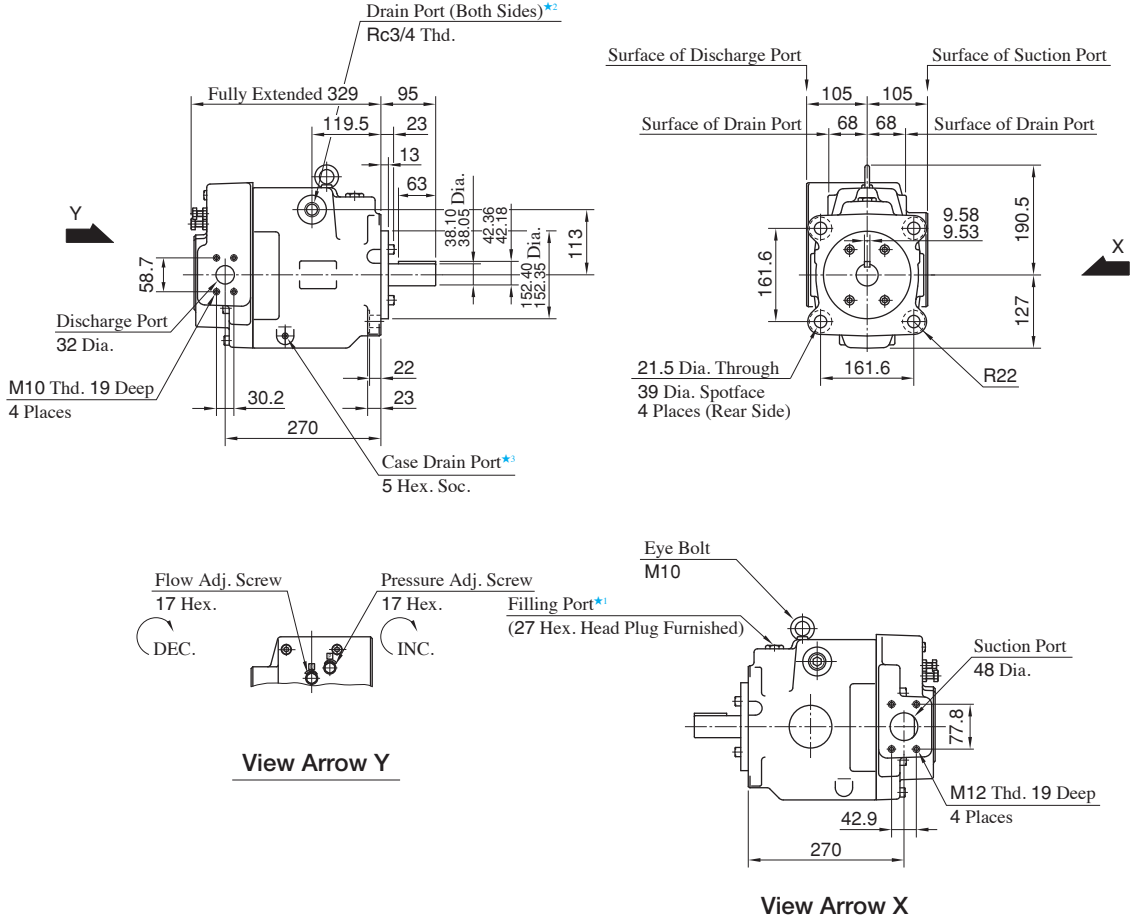

- ★1. Install the pump so that the “Filling Port” is at the top.
- ★2. Use either port of the two drain ports at your option. Keep the remaining port plugged.
- ★3. Case drain port is available for use when draining hydraulic fluid from pump casing.

**Foot Mtg. : A90-LR01 * S
A100-LR01 * S**

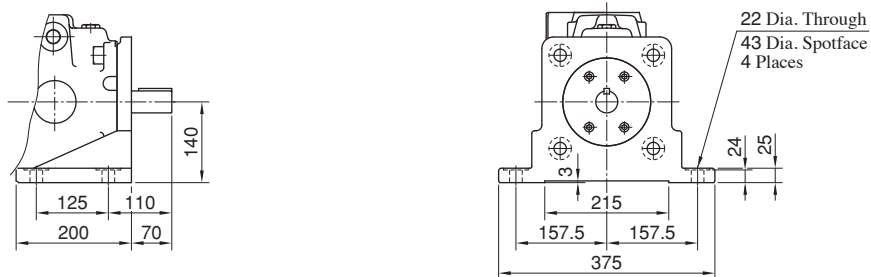

● For other dimensions, refer to “Flange Mtg.”.

Side Port Type

Flange Mtg. : A145-FR01 * S

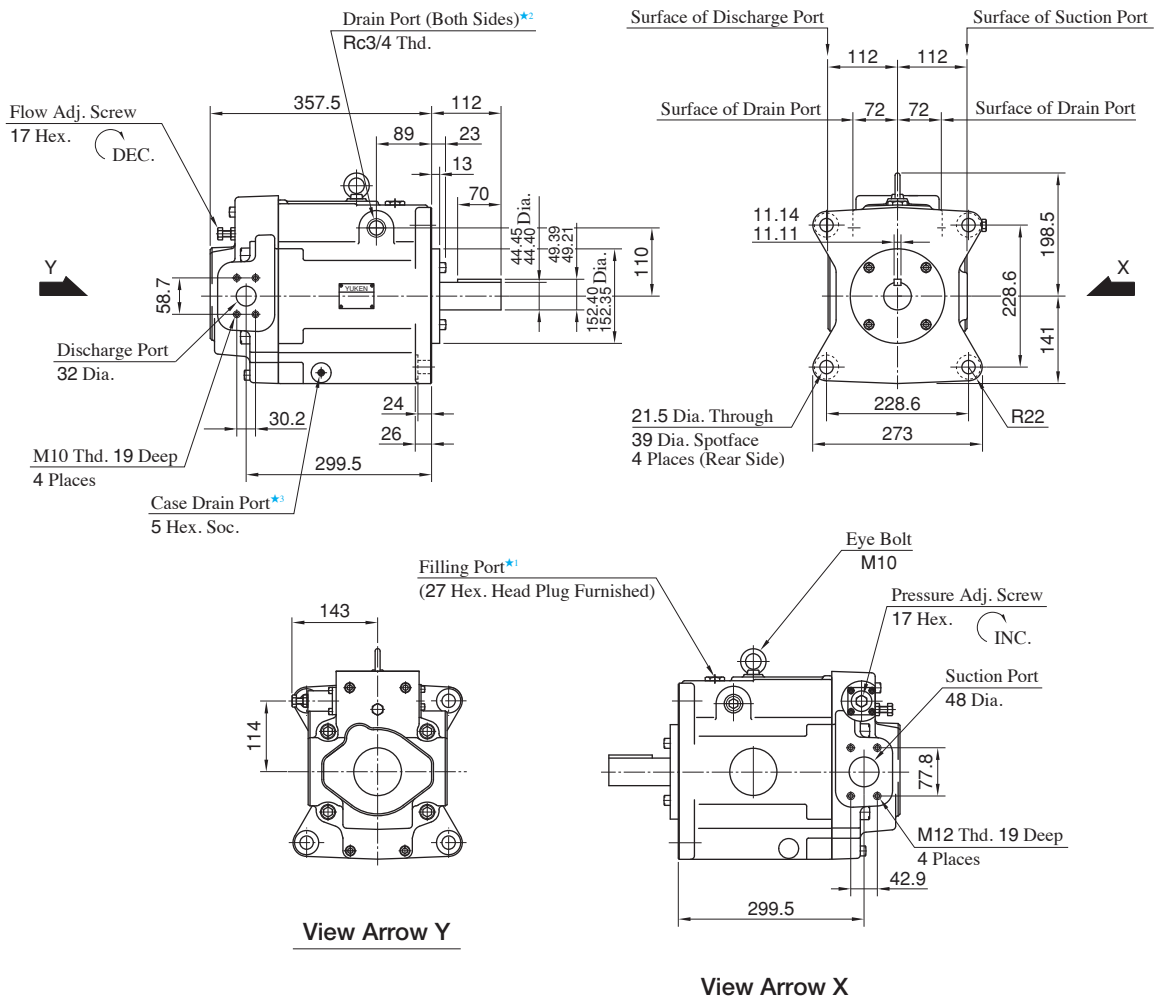

- ★1. Install the pump so that the “Filling Port” is at the top.
- ★2. Use either port of the two drain ports at your option. Keep the remaining port plugged.
- ★3. Case drain port is available for use when draining hydraulic fluid from pump casing.

Foot Mtg. : A145-LR01 * S

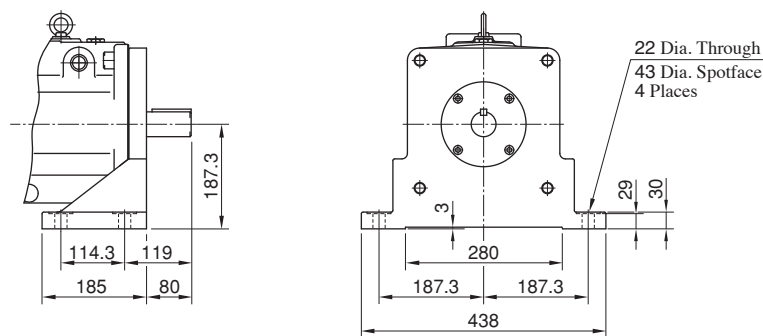

● For other dimensions, refer to “Flange Mtg.”.

Spare Parts List

A10-F-R-01

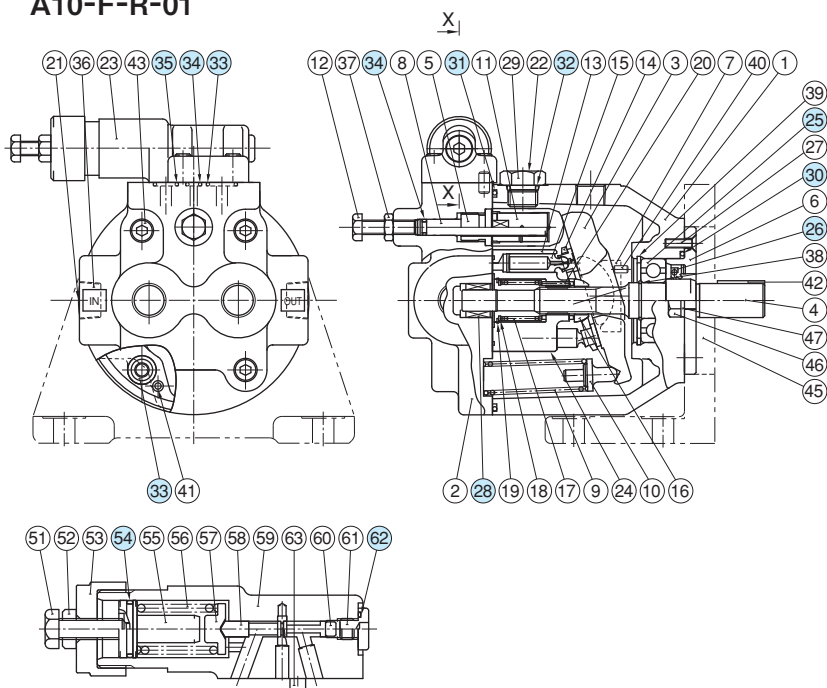

Section X-X

Item	Name of Parts	Part Numbers	Qty.
25	Bearing	6204	1
26	Oil Seal	TCN24408Y	1
28	Bearing	HMK1215	1
30	O-Ring	OR-NBR-70-1 G50-N	1
31	O-Ring	OR-NBR-90 G120-N	1
32	O-Ring	OR-NBR-90 P14-N	1
33	O-Ring	OR-NBR-90 P12-N	5
34	O-Ring	OR-NBR-90 P6-N	2
35	O-Ring	OR-NBR-90 P9-N	1
54	O-Ring	AS568-018 (NBR-70-1)	1
62	O-Ring	OR-NBR-90 P10-N	1

A16/A22/A37/A45/A56- * -R-01

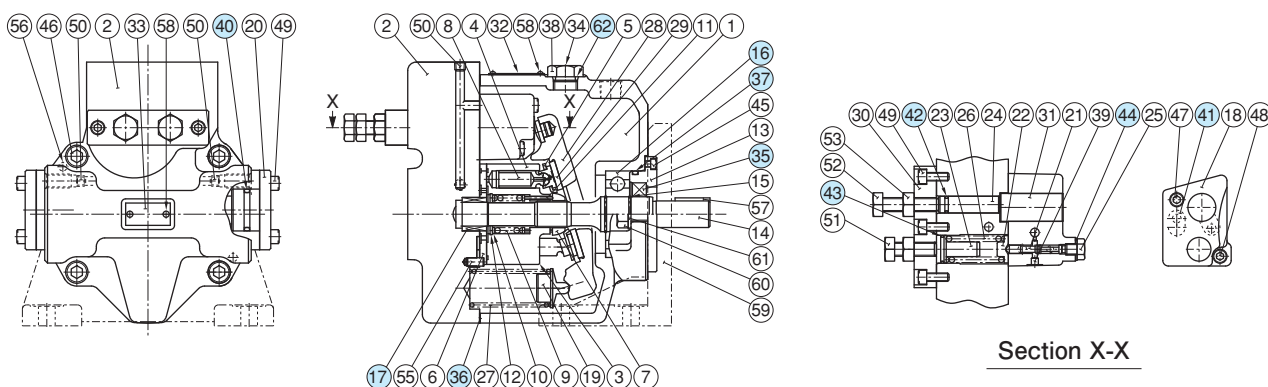

Section X-X

Item	Name of Parts	Part Numbers				Qty.
		A16- *-R-01	A22- *-R-01	A37- *-R-01 A45- *-R-01	A56- *-R-01	
16	Bearing	6305		6307	NUP 207E	1
17	Bearing	HMK 1715	Z30-1303-PK410300-8	HMK 2025V2	HMK 2530V2	1
35	Oil Seal	TCN 254511		TCN 355511	TCN 355511	1
36	Gasket	130-PK211969-1		1316-PK211970-9	1307-PK21197-7	1
37	O-Ring	OR-NBR-70-1 G55-N		OR-NBR-70-1 G75-N		1
40	O-Ring	OR-NBR-70-1 G25-N		OR-NBR-70-1 G30-N	OR-NBR-70-1 P36-N	2
41	O-Ring	OR-NBR-90 P12-N		OR-NBR-90 P10A-N		1
42	O-Ring	OR-NBR-90 P9-N				1
43	O-Ring	AS568-017 (NBR-70-1)				1
44	Seal Washer	W8				1
62	O-Ring	OR-NBR-90 P14-N				1

Spare Parts List

A70/A90/A100- *R01 * S

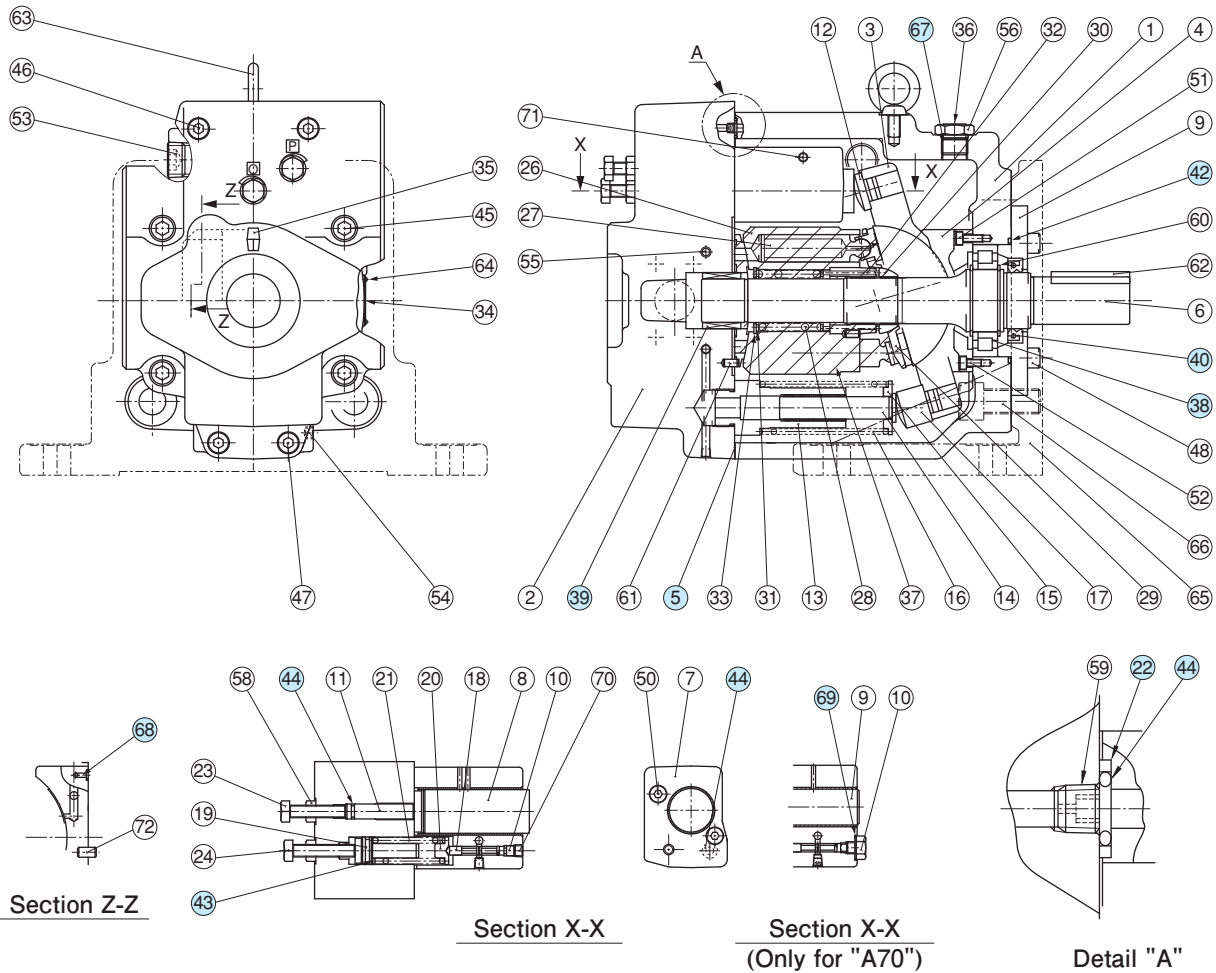

Item	Name of Parts	Part Numbers		Qty.
		A70- *R01 * S	A90- *R01 * S A100- *R01 * S	
5	Gasket	1314E-PK211972-5	1310E-PK211973-3	1
22	Back Up Ring	1310E-PK412440-0	1310E-PK412440-0	1
38	Bearing	NUP 208EX50	NUP 210E	1
39	Needle Bearing	HMK 3030V2	HMK 3530BV2	1
40	Oil Seal	TCN 355511 (FKM)	TCN 456812 (FKM)	1
42	O-Ring	OR-FKM-90 G85-N	OR-FKM-90 G95-N	1
43	O-Ring	OR-NBR-70-1 P18-N	OR-NBR-70-1 P18-N	1
44	O-Ring	OR-NBR-90 P9-N	OR-NBR-90 P9-N	3
67	O-Ring	OR-NBR-90 P14-N	OR-NBR-90 P18-N	1
68	O-Ring	OR-NBR-90 P5-N	OR-NBR-90 P5-N	1
69	Seal Washer	W10	—	1

Spare Parts List

A145-*R01*S

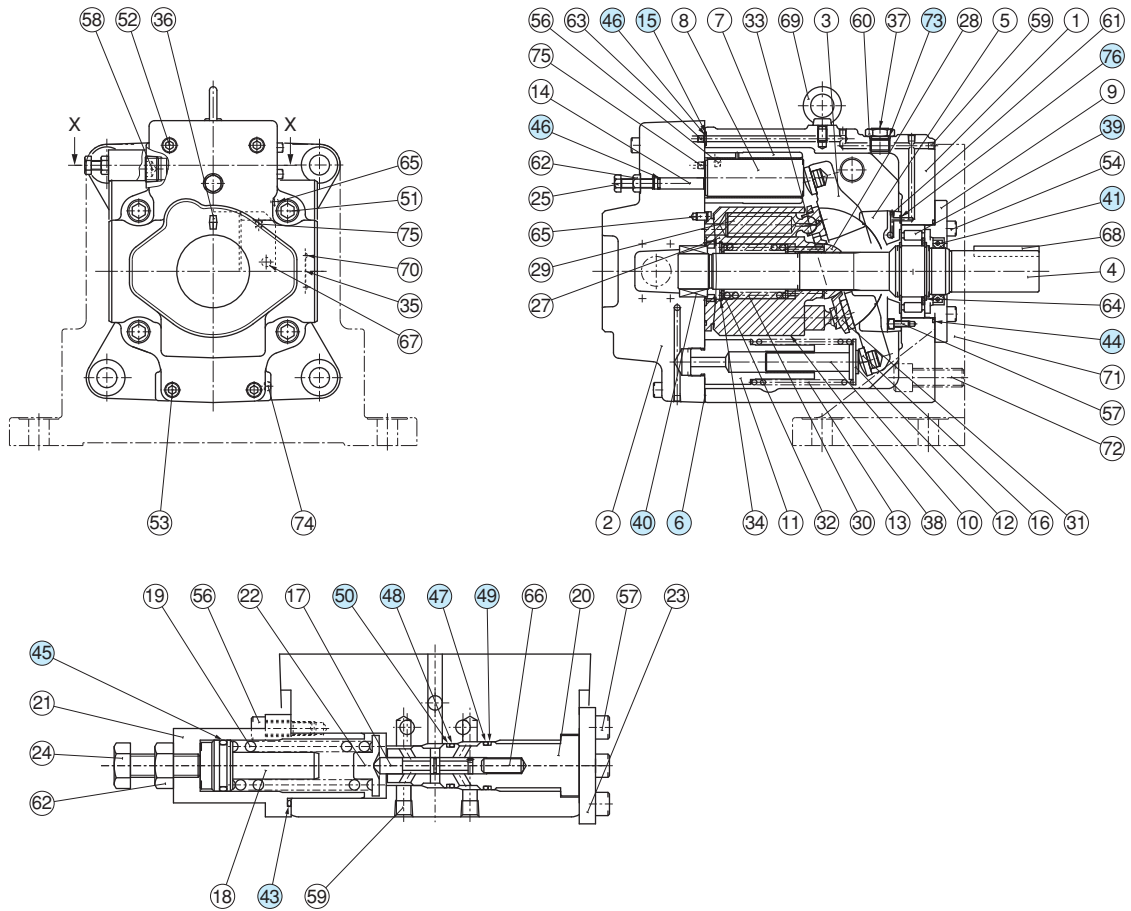

Section X-X

Item	Name of Parts	Part Numbers	Qty.
6	Gasket	1312-PK211974-1	1
15	Back Up Ring	1310E-PK412440-0	1
39	Bearing	NUP 2211ET2	1
40	Needle Bearing	8Q-NK38×55×30	1
41	Oil Seal	TCN 507212 (FKM)	1
43	O-Ring	S-31.5 (NBR-70)	1
44	O-Ring	OR FKM-90 G105-N	1
45	O-Ring	OR NBR-70-1 P18-N	1
46	O-Ring	OR NBR-90 P9-N	2
47	O-Ring	AS568-017 (NBR-70-1)	1
48	O-Ring	AS568-016 (NBR-70-1)	1
49	Back Up Ring	For AS568-017 (NBR-70-1)	1
50	Back Up Ring	For AS568-016 (NBR-70-1)	1
73	O-Ring	OR NBR-90 P18-N	1
76	O-Ring	OR NBR-90 P5-N	1

Series Variable Displacement Piston Pumps, Solenoid Two Pressure Control Type

Graphic Symbol

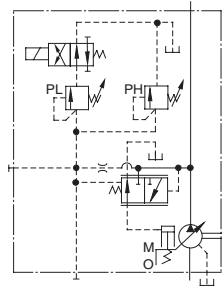

Performance Characteristics

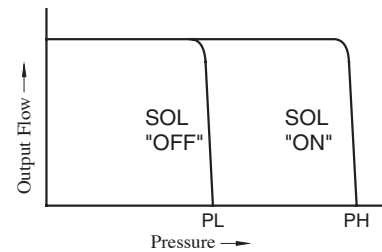

Specifications

Model Numbers	Geometric Displacement cm ³ /rev	Minimum Adj. Flow cm ³ /rev	Operating Pressure MPa		Minimum Adj. Pres. MPa	Shaft Speed Range r/min		Approx. Mass kg	
			Rated★2	Intermittent★1		Max.	Min.	Flange Mtg.	Foot Mtg.
A16- *-R-02- *-K *-32	15.8	4	16	21	1.2	1800	600	24.5	26.7
A22- *-R-02- *-K *-32	22.2	6	16	16	1.2	1800	600	24.5	26.7
A37- *-R-02- *-K *-32	36.9	10	16	21	1.2	1800	600	36	40.3
A56- *-R-02- *-K *-32	56.2	12	16	21	1.2	1800	600	43	47.3
A70- *R02S *-70	70.0	36	25	25	2	1800	600	63.5	75.5
A90- *R02S *-70	91.0	56	25	25	2	1800	600	80.5	101
A145- *R02S *-60	145	83	25	25	2	1800	600	97.5	122.5

★1. Whenever setting pressure, make sure the full cut-off pressure never exceeds the maximum intermittent pressure.

★2. When operating the pump exceeding the rated pressure, operating conditions are restricted. Refer to page A-28 for the details.

Solenoid Ratings

Electric Source	Coil Type	Frequency (Hz)	Voltage (V)		Current & Power at Rated Voltage		
			Source Rating	Serviceable Range	Inrush (A)★2	Holding (A)	Power (W)
AC	A100	50	100	80 - 110	2.42	0.51	—
			100	90 - 120	2.14	0.37	
					2.35	0.44	
	A120	50	120	96 - 132	2.02	0.42	
			108 - 144	1.78	0.31		
	A200	50	200	160 - 220	1.21	0.25	
			200	180 - 240	1.07	0.19	
					1.18	0.22	
	A240	50	240	192 - 264	1.01	0.21	
				216 - 288	0.89	0.15	
DC (K Series)	D12	—	12	10.8 - 13.2	—	2.45	29
	D24		24	21.6 - 26.4		1.23	
	D48		48	43.2 - 52.8		0.61	
AC→DC Rectified(R)★1	R100	50/60	100	90 - 110	—	0.33	29
	R200		200	180 - 220		0.16	

★1. R type models with built-in current rectifier is recommended for shockless operation with AC power.

★2. Inrush current in the above table show rms values at maximum stroke.

Model Number Designation

A16	-F	-R	-02	-S	-K	-A100	-32
Series Number	Mounting	Direction of Rotation	Control Type	Port Position	Shaft Extension	Coil Type of Solenoid Valve	Design Number
A16 (15.8 cm ³ /rev)	F: Flange Mtg. L: Foot Mtg.	(Viewed from Shaft End) R: Clockwise ^{★1} (Normal)	02: Solenoid Two Pressure Control Type	None: Axial Port S: Side Port	K: Keyed Shaft	AC A100, A120 A200, A240 DC D12, D24 D48 R (AC→DC Rectified) R100, R200	32
A22 (22.2 cm ³ /rev)							32
A37 (36.9 cm ³ /rev)							32
A56 (56.2 cm ³ /rev)							32

A70	-F	R	02	S	A100	-70
Series Number	Mounting	Direction of Rotation	Control Type	Port Position	Coil Type of Solenoid Valve	Design Number
A70 (70.0 cm ³ /rev)	F: Flange Mtg. L: Foot Mtg.	(Viewed from Shaft End) R: Clockwise ^{★1} (Normal)	02: Solenoid Two Pressure Control Type	S: Side Port	AC A100, A120 A200, A240 DC D12, D24 D48 R (AC→DC Rectified) R100, R200	70
A90 (91.0 cm ³ /rev)						70
A145 (145 cm ³ /rev)						60

★1. Available to supply pump with anti-clockwise rotation. Consult Yuken for details.

Performance Characteristics

For performance characteristics, refer to models of pressure compensator type on page A-32 to A-34, A-36 to A-38 and A-40.

Pipe Flange Kits

For pipe flange, refer to form of pressure compensator type on page A-29.

Axial Port Type

Flange Mtg. : A16-F-R-02-K
A22-F-R-02-K

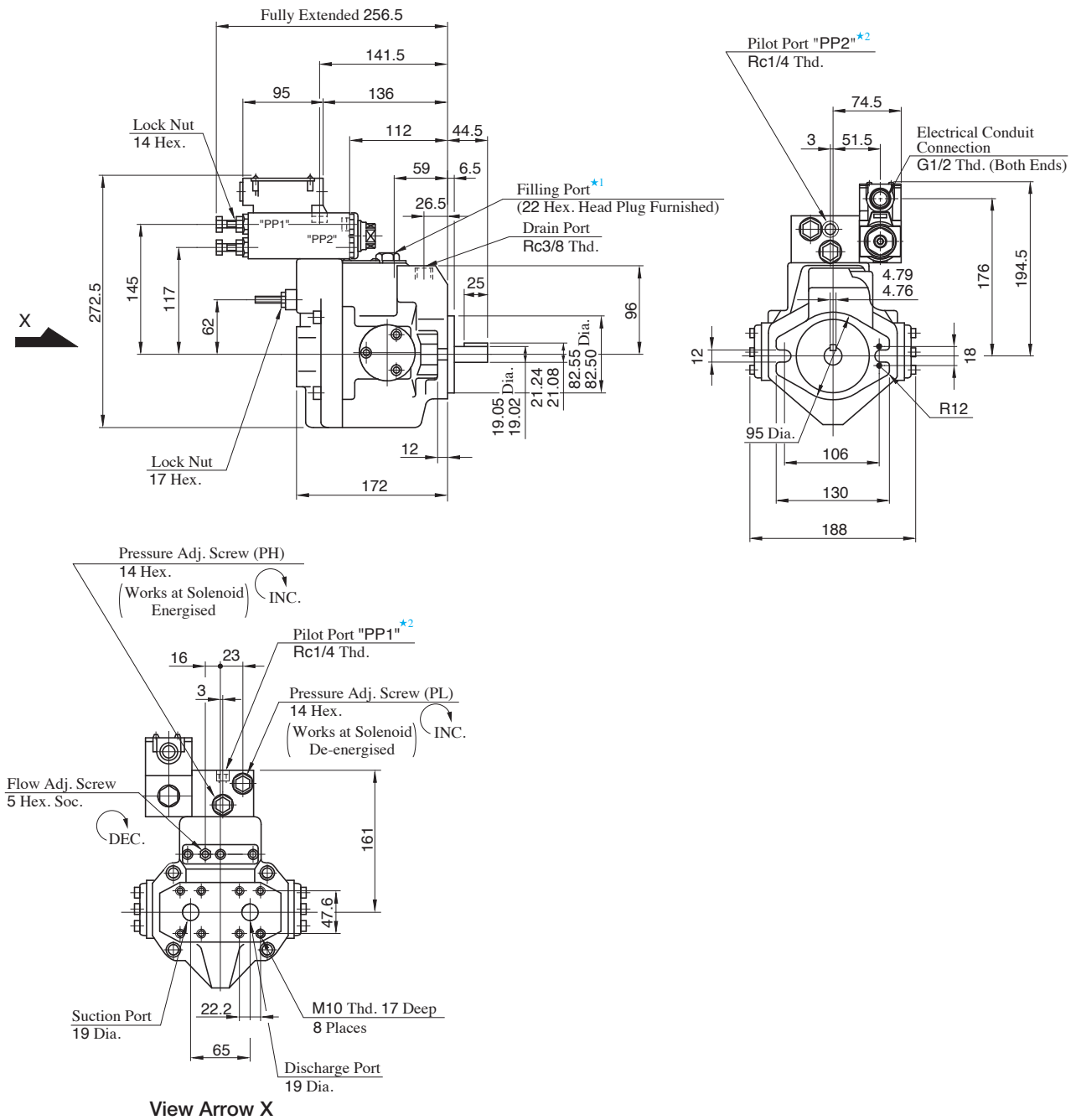

- ★1. Install the pump so that the "Filling Port" is at the top.
- ★2. The pilot port provided is for connecting a control valve, if multistage pressure control is required.

● Side Port Type

Port mounting dimensions are the same as those of pressure compensator model. Refer to page A-42 for port mounting dimensions.

● Foot Mounting Type

Mounting bracket is common to that of pressure compensator model. Refer to page A-42 for the dimensions of mounting bracket.

Side Port Type

Flange Mtg. : A37-F-R-02-S-K

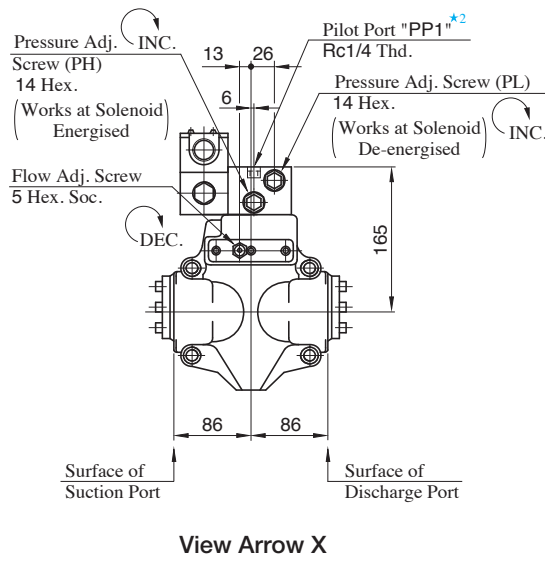
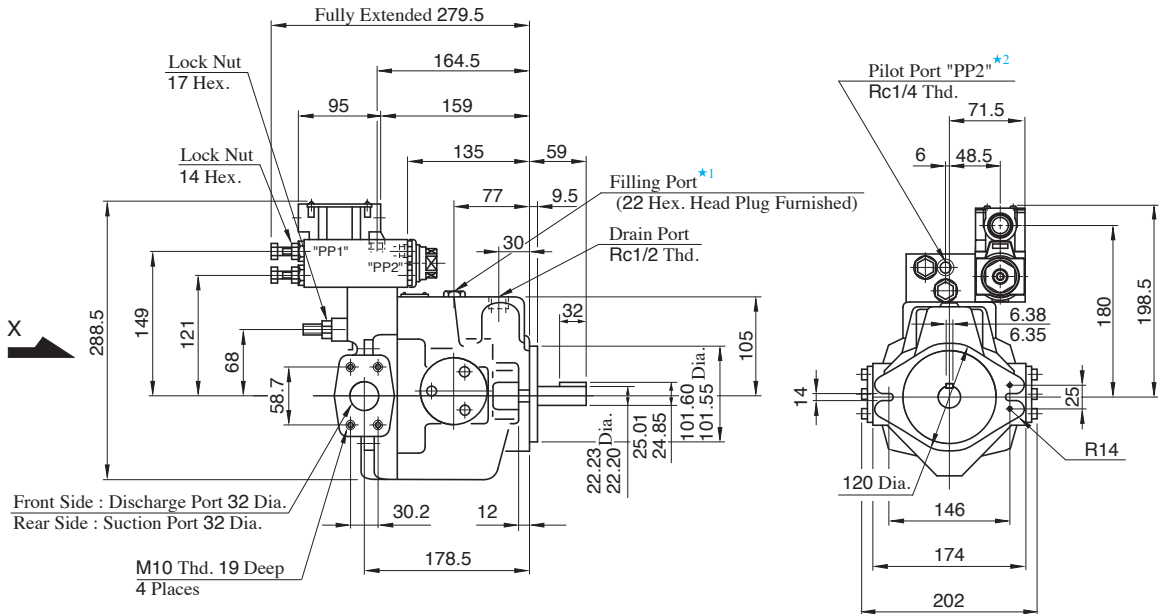

- ★1. Install the pump so that the "Filling Port" is at the top.
- ★2. The pilot port provided is for connecting a control valve, if multistage pressure control is required.

● Axial Port Type

Port mounting dimensions are the same as those of pressure compensator model.
Refer to page A-43 for port mounting dimensions.

● Foot Mounting Type

Mounting bracket is common to that of pressure compensator model.
Refer to page A-43 for the dimensions of mounting bracket.

Side Port Type

Flange Mtg. : A56-F-R-02-S-K

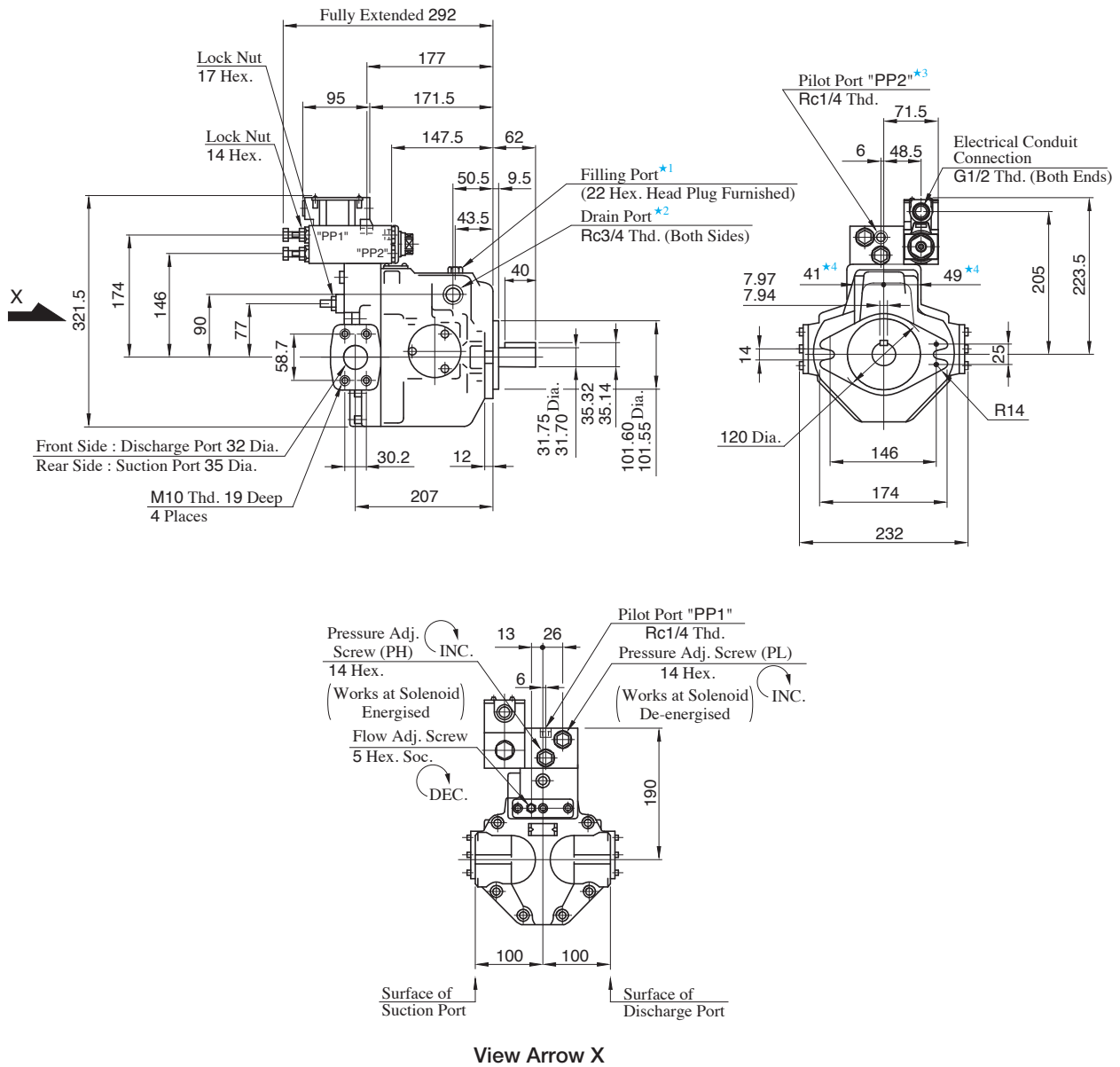

- ★1. Install the pump so that the "Filling Port" is at the top.
- ★2. Use either port of two drain ports at your option. Keep the remaining port plugged.
- ★3. The pilot port provided is for connecting a control valve, if multistage pressure control is required.
- ★4. Dimensions show surface of drain port.

● Axial Port Type

Port mounting dimensions are the same as those of pressure compensator model. Refer to page A-44 for port mounting dimensions.

● Foot Mounting Type

Mounting bracket is common to that of pressure compensator model. Refer to page A-44 for the dimensions of mounting bracket.

Flange Mtg. : A70-FR02 *

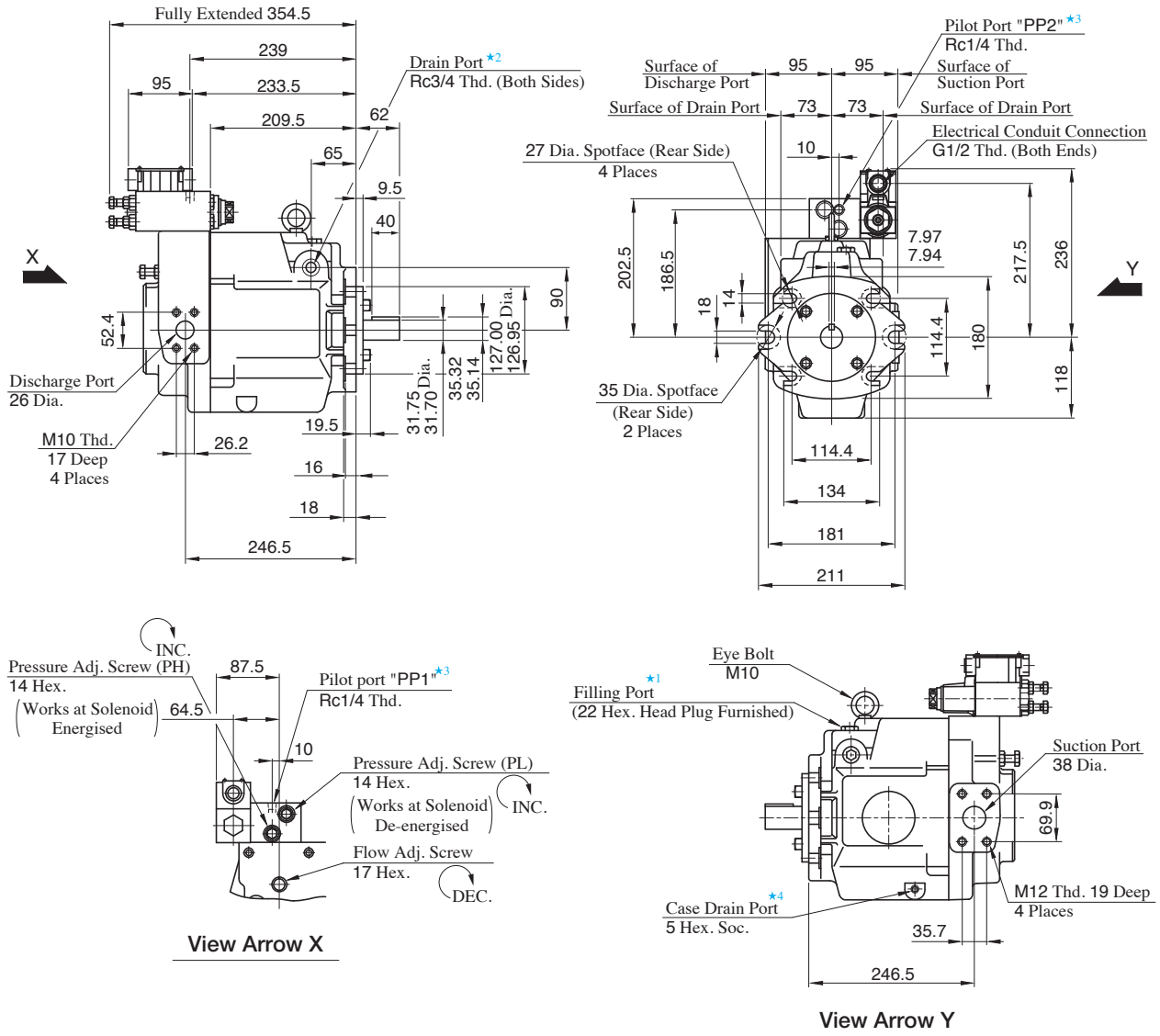

- ★1. Install the pump so that the "Filling Port" is at the top.
- ★2. Use either port of two drain ports at your option. Keep the remaining port plugged.
- ★3. The pilot port provided is for connecting a control valve, if multistage pressure control is required.
- ★4. Case drain port is available for use when draining hydraulic fluid from pump casing.

● Foot Mounting Type

Mounting bracket is common to that of pressure compensator model.
Refer to page A-45 for the dimensions of mounting bracket.

Flange Mtg. : A90-FR02 *

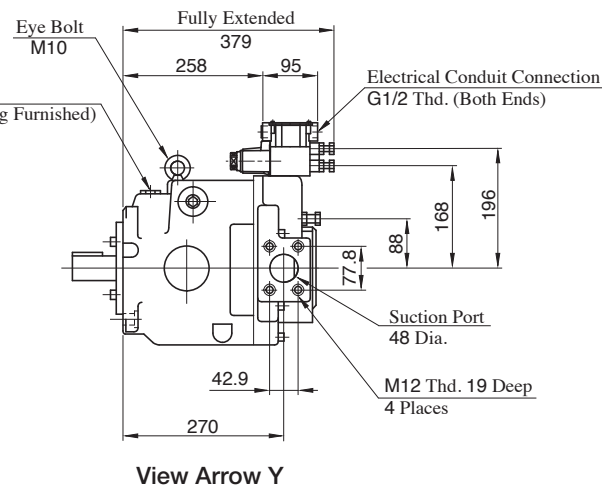
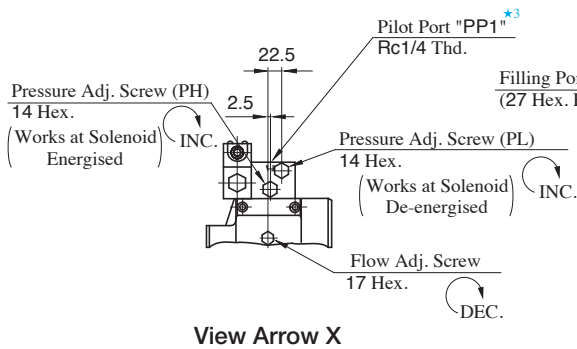
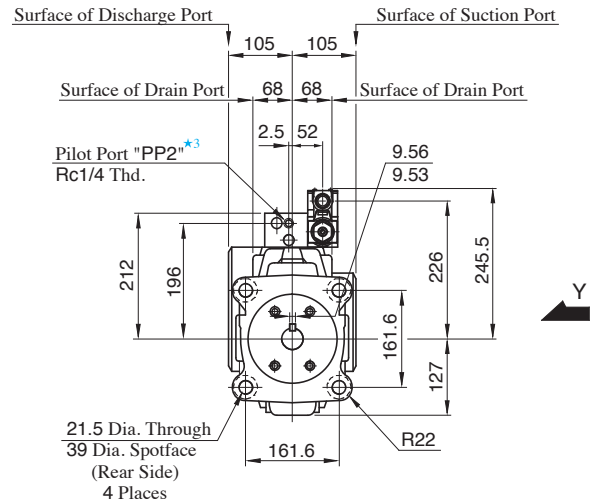
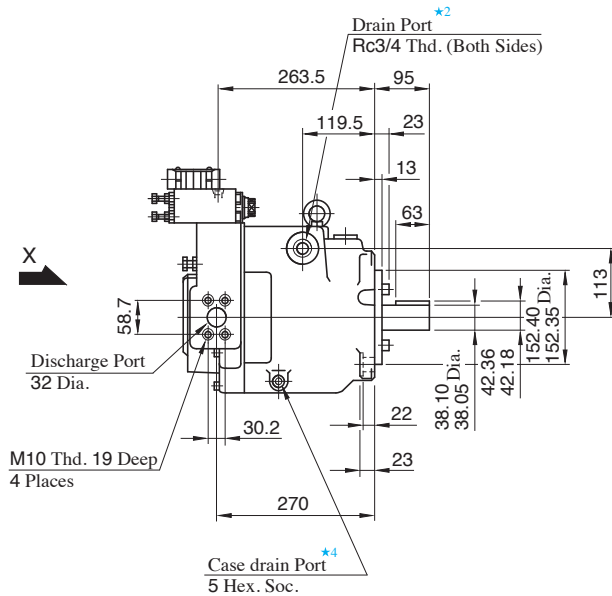

- ★1. Install the pump so that the "Filling Port" is at the top.
- ★2. Use either port of two drain ports at your option. Keep the remaining port plugged.
- ★3. The pilot port provided is for connecting a control valve, if multistage pressure control is required.
- ★4. Case drain port is available for use when draining hydraulic fluid from pump casing.

● Foot Mounting Type

Mounting bracket is common to that of pressure compensator model.
Refer to page A-46 for the dimensions of mounting bracket.

Flange Mtg. : A145-FR02 *

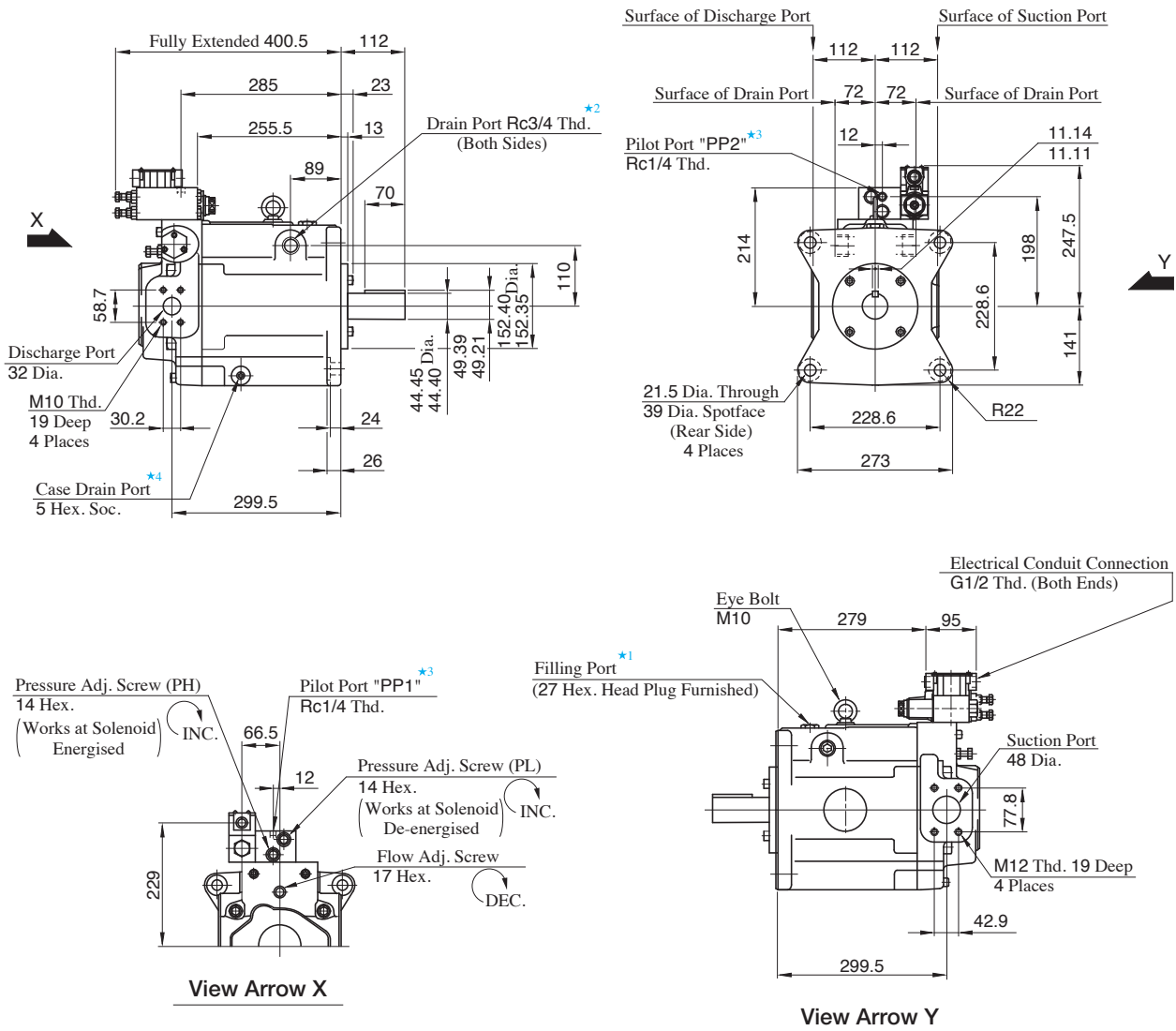

- ★1. Install the pump so that the "Filling Port" is at the top.
- ★2. Use either port of two drain ports at your option. Keep the remaining port plugged.
- ★3. The pilot port provided is for connecting a control valve, if multistage pressure control is required.
- ★4. Case drain port is available for use when draining hydraulic fluid from pump casing.

● Foot Mounting Type

Mounting bracket is common to that of pressure compensator model.
Refer to page A-47 for the dimensions of mounting bracket.

Series Variable Displacement Piston Pumps, Pressure Compensator with Unloading Type

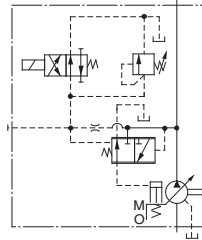
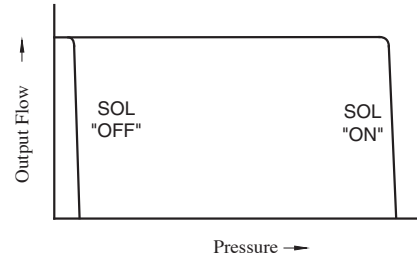
Graphic Symbol

Performance Characteristics

Specifications

Model Numbers	Geometric Displacement cm ³ /rev	Minimum Adj. Flow cm ³ /rev	Operating Pressure MPa		Unloading Pressure MPa	Shaft Speed Range r/min	
			Rated	Intermittent		Max.	Min.
A16- *-R-03- *-K- *-32	15.8	4	16	21	1.2	1800	600
A22- *-R-03- *-K- *-32	22.2	6	16	16	1.2	1800	600
A37- *-R-03- *-K- *-32	36.9	10	16	21	1.2	1800	600
A56- *-R-03- *-K- *-32	56.2	12	16	21	1.2	1800	600
A70- *R03S* -70	70.0	36	25	25	1.2	1800	600
A90- *R03S* -70	91.0	56	25	25	1.2	1800	600
A145- *R03S* -60	145	83	25	25	1.2	1800	600

Model Number Designation

A16	-F	-R	-03	-S	-K	-A100	-32
Series Number	Mounting	Direction of Rotation	Control Type	Port Position	Shaft Extension	Coil Type of Solenoid Valve	Design Number
A16 (15.8 cm ³ /rev)	F: Flange Mtg. L: Foot Mtg.	(Viewed from) Shaft End R: Clockwise ^{*1} (Normal)	03: Pressure Compensator with Unloading Type	None: Axial Port S: Side Port	K: Keyed Shaft	AC A100, A120 A200, A240 DC D12, D24 D48 R (AC→DC Rectified) R100, R200	32
A22 (22.2 cm ³ /rev)							32
A37 (36.9 cm ³ /rev)							32
A56 (56.2 cm ³ /rev)							32

A70	-F	R	03	S	A100	-70
Series Number	Mounting	Direction of Rotation	Control Type	Port Position	Coil Type of Solenoid Valve	Design Number
A70 (70.0 cm ³ /rev)	F: Flange Mtg. L: Foot Mtg.	(Viewed from) Shaft End R: Clockwise ^{*1} (Normal)	03: Pressure Compensator with Unloading Type	S: Side Port	AC A100, A120 A200, A240 DC D12, D24 D48 R (AC→DC Rectified) R100, R200	70
A90 (91.0 cm ³ /rev)						70
A145 (145 cm ³ /rev)						60

^{*1} Available to supply pump with anti-clockwise rotation. Consult Yuken for details.

Consult Yuken when detailed material such as dimensions figures is required.

Series Variable Displacement Piston Pumps, Proportional Electro-Hydraulic Load Sensing Type

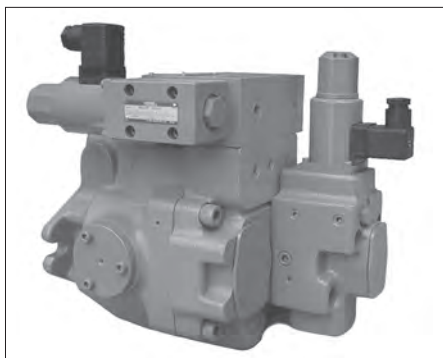

Performance Characteristics

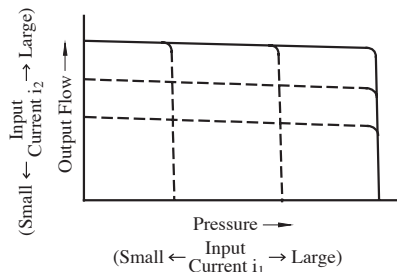

Graphic Symbols

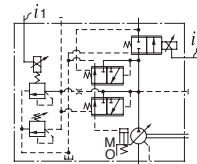

A16/A22/A37/A56

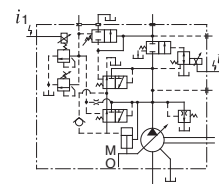

A70/A90/A100/A145

Model Number Designation

A56	-F	-R	-04	-C	-K	-32
Series Number	Mounting	Direction of Rotation	Control Type	Pressure Adj. Range MPa	Shaft Extension	Design Number
A16 (15.8 cm ³ /rev)	F: Flange Mtg. L: Foot Mtg.	(Viewed from) Shaft End R: Clockwise ^{★1}	04: Proportional Electro-Hydraulic Load Sensing Type	B: 1.5 - 6.9 (220 - 1000) C: 1.5 - 15.7 (220 - 2280) H: 1.5 - 20.6 (220 - 2990)	K: Keyed Shaft	32
A22 (22.2 cm ³ /rev)				B: 1.5 - 6.9 (220 - 1000) C: 1.5 - 15.7 (220 - 2280)		32
A37 (36.9 cm ³ /rev)				B: 2 - 6.9 (290 - 1000) C: 2 - 15.7 (290 - 2280) H: 2 - 20.6 (290 - 2990)		32
A56 (56.2 cm ³ /rev)				B: 2 - 6.9 (290 - 1000) C: 2 - 15.7 (290 - 2280) H: 2 - 20.6 (290 - 2990)		32

A70	-F	R	04	C	S	-70
Series Number	Mounting	Direction of Rotation	Control Type	Pressure Adj. Range MPa	Port Position	Design Number
A70 (70.0 cm ³ /rev)	F: Flange Mtg. L: Foot Mtg.	(Viewed from) Shaft End R: Clockwise ^{★1}	04: Proportional Electro-Hydraulic Load Sensing Type	C: 1.5 - 16 (220 - 2320) H: 1.5 - 21 (220 - 3050)	S: Side Port	70
A90 (91.0 cm ³ /rev)						70
A100 (100 cm ³ /rev)						20
A145 (145 cm ³ /rev)						60

★1. Available to supply pump with anti-clockwise rotation. Consult Yuken for details.

Pipe Flange Kits

Pipe flange kits are available. When ordering, specify the kit number from the table below.

Pump Model Numbers	Name of Port	Pipe Flange Kit Numbers		
		Threaded Connection	Socket Welding ^{*1}	Butt Welding
A16- *-R-04	Suction	F5-06-A-10	F5-06-B-10	F5-06-C-10
A22- *-R-04	Discharge	— ^{*2}	— ^{*2}	— ^{*2}
A37- *-R-04	Suction	F5-10-A-10	F5-10-B-10	F5-10-C-10
A56- *-R-04	Discharge	F5-06-A-10	F5-06-B-10	F5-06-C-10
A 70- *R04	Suction	F5-12-A-10	F5-12-B-10	F5-12-C-10
	Discharge	F5-10-A-10	F5-10-B-10	F5-10-C-10
A 90- *R04	Suction	F5-16-A-10	F5-16-B-10	F5-16-C-10
A100- *R04		F5-10-A-10	F5-10-B-10	F5-10-C-10
A145- *R04				

★1. In case of using socket welding flanges, there is a case where the operating pressure should be set lower than the normal because of strength of the flanges. Therefore, please pay cautious attention to the operating pressure when the socket welding flanges are used.

★2. Discharge port for pump model "A16" and "A22" is available only the threaded connections.

● Details of the pipe flange kits are shown on pages A-258 and A-259.

Instructions

Bleeding Air

In order to get steadily controlled pressure and flow, bleed air by loosening the air vent screw and fill solenoid armature with operating oil.

Manual Adjustment Screws

Manual adjustment screws may be used for initial running adjustment or in case of electrical failures in order to adjust pressure and flow temporarily. In case of normal use, put the manual adjustment screws back in their preset positions.

Position of Cable Departure

Position of cable departure can be changed. For details, refer to drawing below.

Connection of Surge Cut-off Valve to "A" Series Pump (For A16 to A56 Type)

If using surge cut-off valve (SF1105-A-10), connect between pilot port "PP" of this pump and port "PP" of surge cut-off valve as pilot piping (refer to symbol below).

Inside diameter of pipe should be more than 8 mm.

Consult Yuken for details of surge cut-off valve.

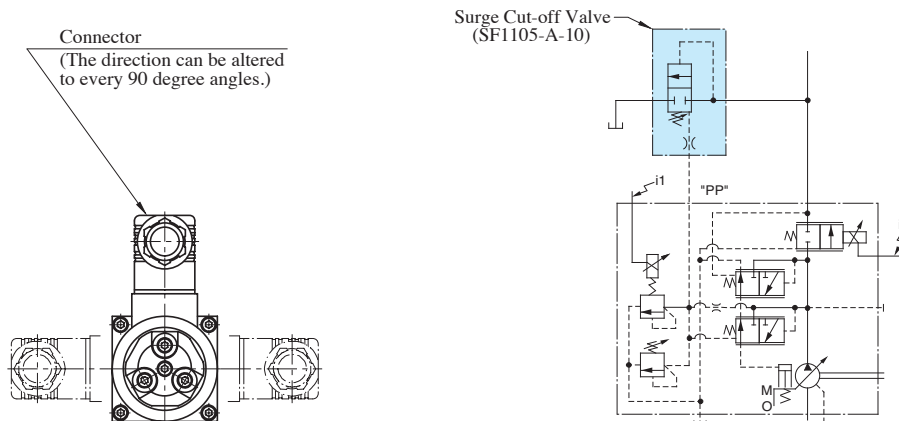

Specifications

Descriptions		Model Numbers		A16	A22	A37	A56	A70	A90	A100	A145
Geometric Displacement		cm ³ /rev		15.8	22.2	36.9	56.2	70.0	91.0	100	145
Operating Pressure MPa		Rated ^{*2}		16	16	16	16	21	21	21	21
		Intermittent ^{*1}		21	16	21	21	21	21	21	21
Shaft Speed Range r/min		Max.		1800	1800	1800	1800	1800	1800	1800	1800
		Min.		600	600	600	600	600	600	600	600
Flow Control	Flow Adj. Range	L/min		1 - 28.4	1 - 40	1 - 66	1 - 101	1 - 126	1 - 163	1 - 180	2 - 261
	Min. Pres. Required for Flow Adj.	MPa		1.5	1.5	1.5	2.0	1.0	1.0	1.0	1.0
	Differential Pres. (Discharge Pres. - Load Pres.)	MPa		0.37				0.22			
	Step Response ^{*5} (0 → Max. Flow)	ms		70	80	120	125	100	120	120	210
	Hysteresis			3 % or less ^{*1}							
	Rated Current	mA		900	700	740	790	820	920	945	920
	Coil Resistance (20°C)	Ω		10							
Pres. Control	Pres. Adj. Range	MPa		Refer to Model Number Designation							
	Step Response ms	t ₁ ^{*5}		80	80	50	55	150	150	150	160
		t ₂ ^{*5}		140	90	80	80	80	120	120	180
	Hysteresis			2 % or less ^{*1}							
	Rated Current	mA		(Pres. Adj. Range) B: 770, C: 880, H: 790				C: 860 H: 765	C: 873 H: 765	C: 873 H: 765	C: 875 H: 755
Coil Resistance (20°C)	Ω		10								
Applicable Amplifier Model ^{*3}				AME-D2-1010-11							
Approx. Mass kg	Flange Mtg.		32	32	38	45	70	88.5	88	109.5	
	Foot Mtg.		34.2	34.2	43.2	49.3	82	109	104	134.5	

- ★1. Whenever setting pressure, make sure the full cut-off pressure never exceeds the maximum intermittent pressure.
- ★2. When operating the pump exceeding the rated pressure, operating conditions are restricted. Refer to page A-28 for details.
- ★3. Specifications of power amplifiers, consult Yuken for details.
- ★4. The figure mentioned in the above table are those obtained using Yuken's amplifier.
- ★5. Step response depends on circuit and operating conditions. Data shown in the table above is an example based on the condition right.

Model	Pres. Step Response		Loading Volume
	t ₁	t ₂	
A16, A22	1.5 → 16 MPa	16 → 1.5 MPa	High Pressure Hose 3/8" × 2 m
A37, A56	2.0 → 16 MPa	16 → 2.0 MPa	High Pressure Hose 3/4" × 2 m
A70, A90 A100, A145	3.0 → 16 MPa	16 → 3.0 MPa	High Pressure Hose 1-1/4" × 2 m

Typical Performance Characteristics at Viscosity 20 mm²/s [ISO VG32 Oils, 50°C]

Full Cut-off Pres. vs. Input Signal

● A16/A22/A37/A56

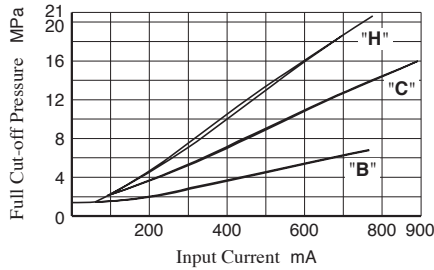

● A70/A90/A100/A145

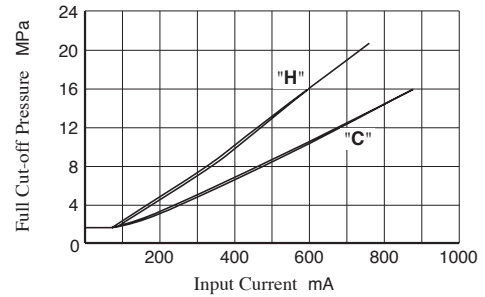

Note: Pressure adjustment range "H" is not available for A22.

Output Flow vs. Input Current

● A16

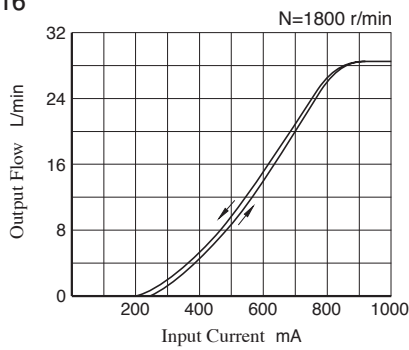

● A70

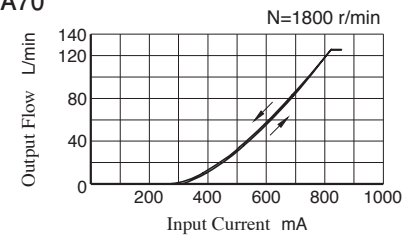

● A22

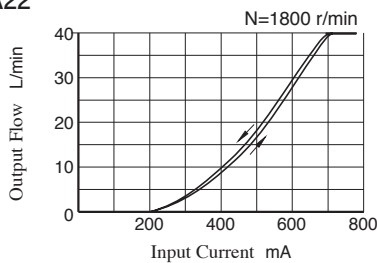

● A90

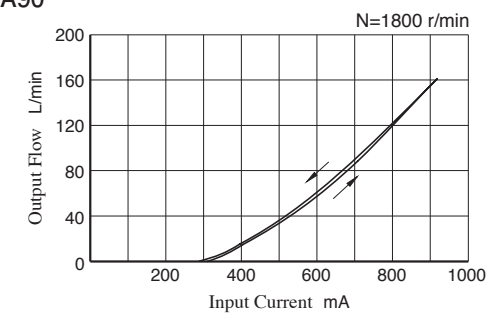

● A37

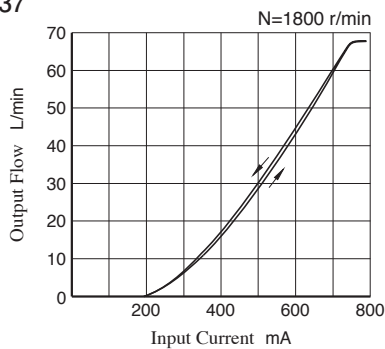

● A100

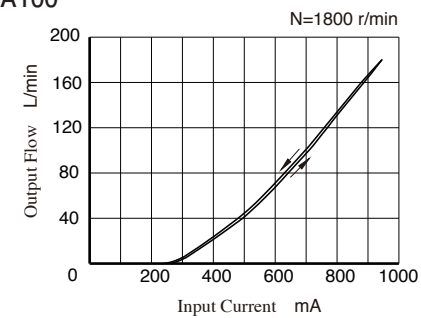

● A56

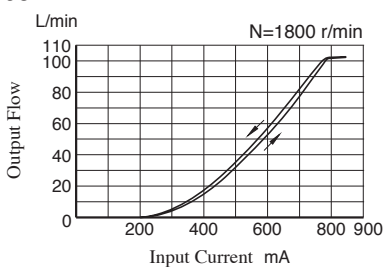

● A145

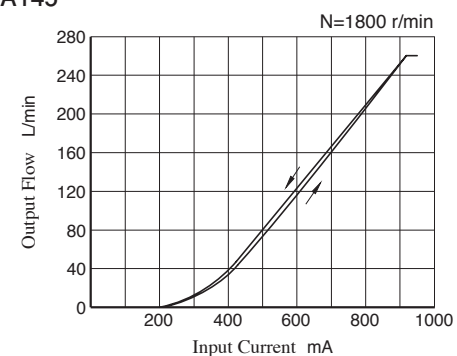

Flange Mtg. : A16-F-R-04 * -K
A22-F-R-04 * -K

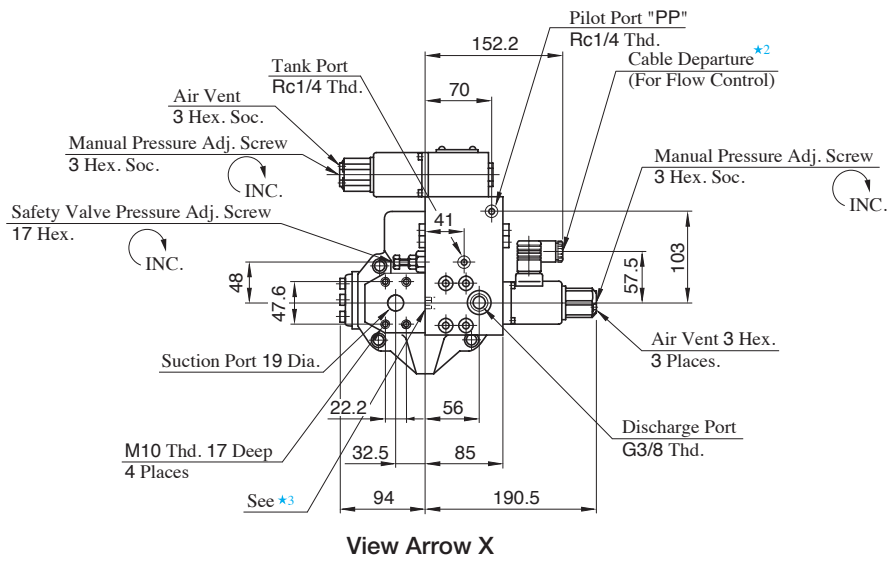
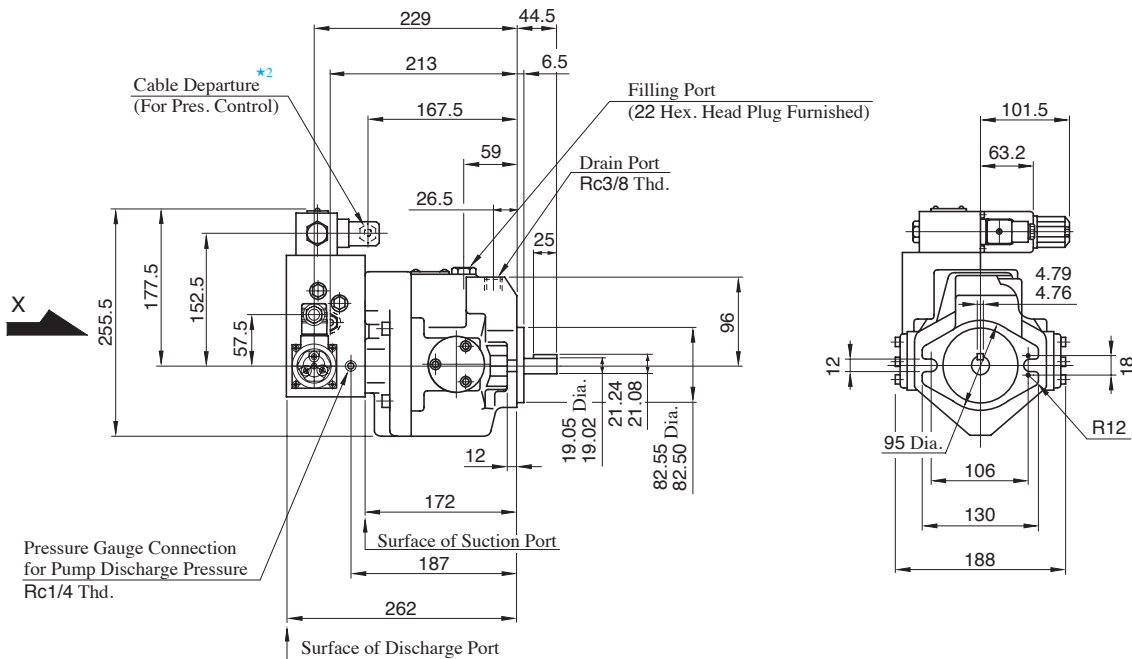

★ 1. Detail of Discharge Port

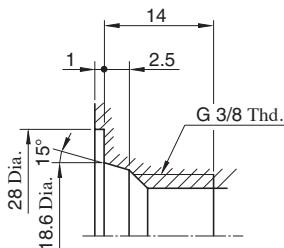

★ 2. Cable Applicable:

Outside Dia.....8-10 mm
Conductor Area.....Not Exceeding 1.5 mm²

★ 3. Do not touch the screw because it is adjusted at the time of shipment.

● Foot Mounting Type

Mounting bracket is common to that of pressure compensator model.
Refer to page A-42 for the dimensions of mounting bracket.

Flange Mtg. : A37-F-R-04 *-K

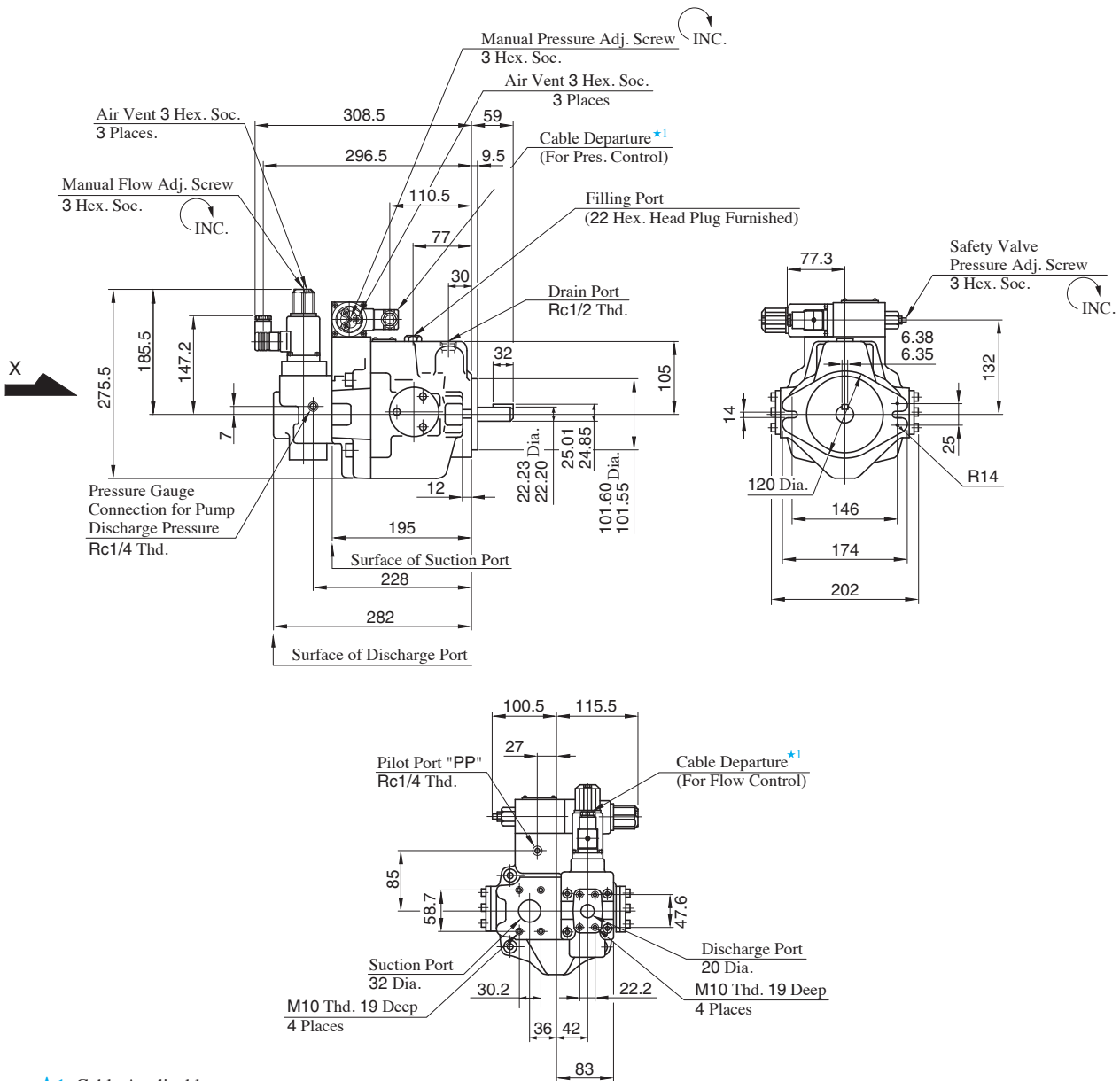

★1. Cable Applicable:
 Outside Dia.....8-10 mm
 Conductor Area.....Not Exceeding 1.5 mm²

View Arrow X

Foot Mtg. : A37-L-R-04 *-K

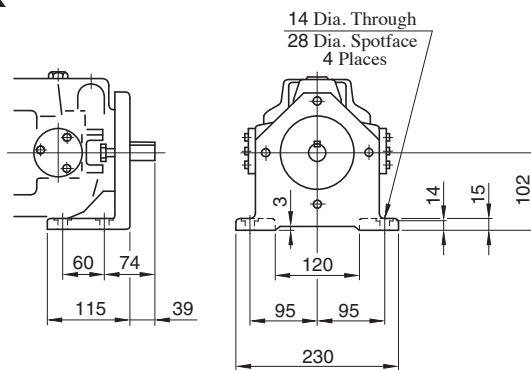

● For other dimensions, refer to "Flange Mtg."

Flange Mtg. : A56-F-R-04 *-K

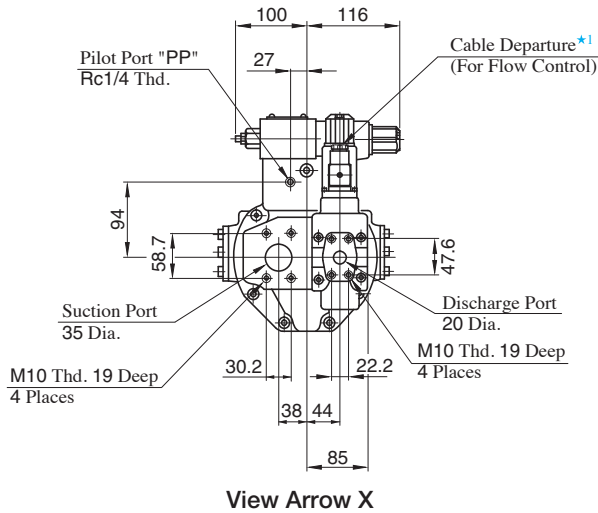
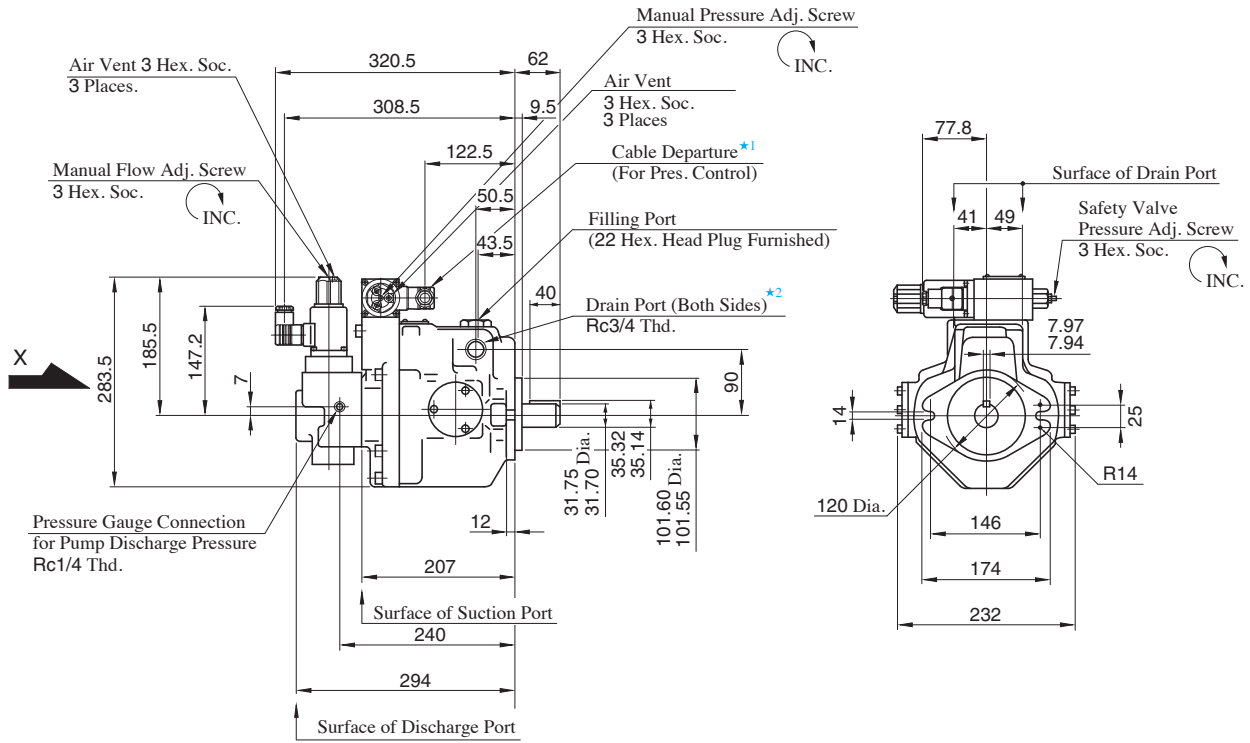

- ★1. Cable Applicable:
Outside Dia.....8-10 mm
Conductor Area.....Not Exceeding 1.5 mm²
- ★2. Use either port of two drain ports at your option.
Keep the remaining port plugged.

Foot Mtg. : A56-L-R-04 *-K

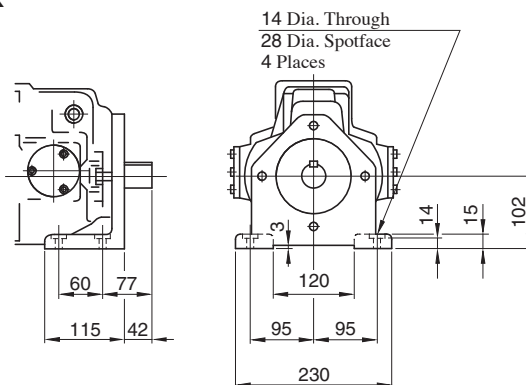

● For other dimensions, refer to "Flange Mtg."

Flange Mtg. : A70-FR04 * S

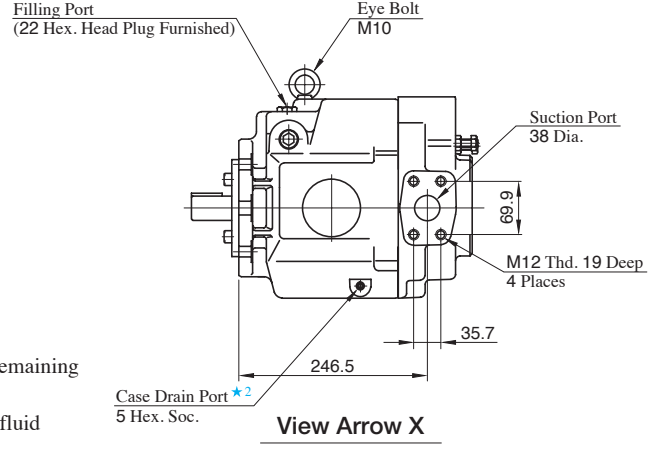
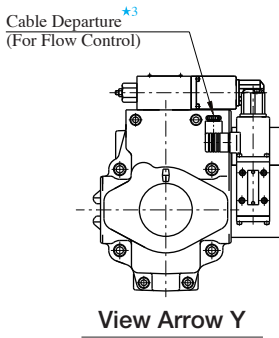
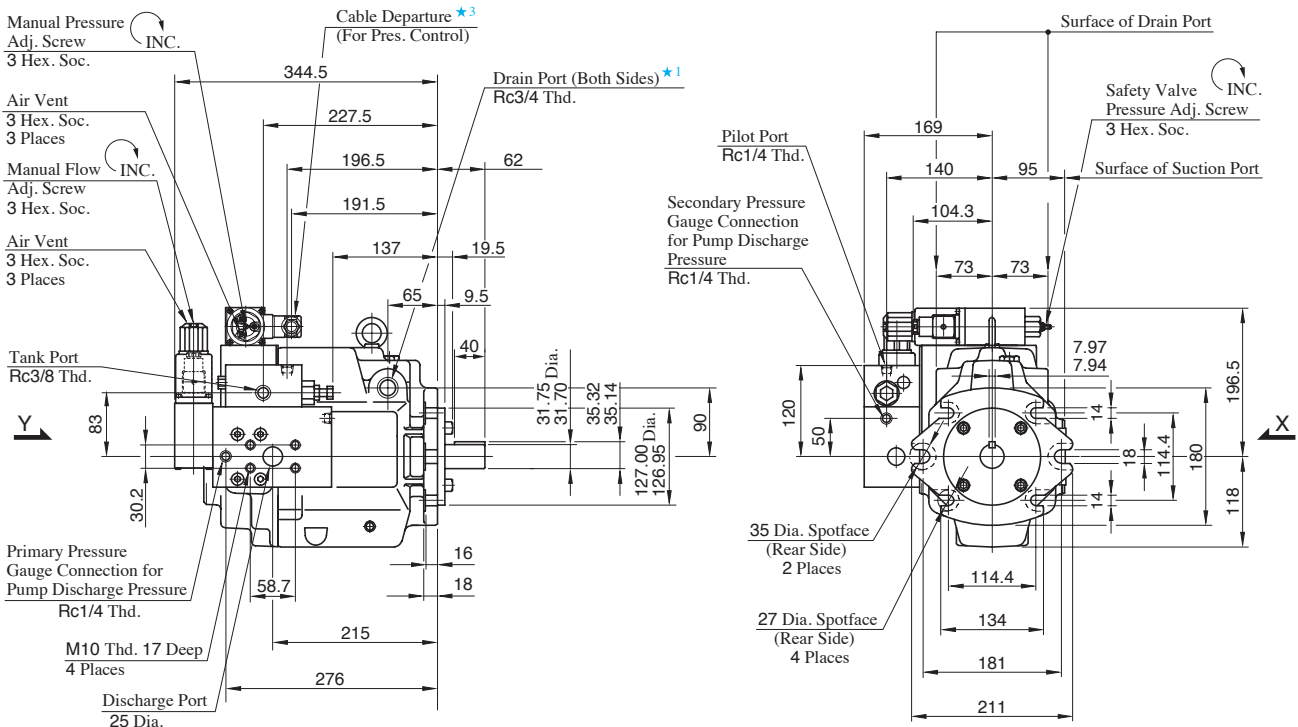

- ★1. Use either port of two drain ports at your option. Keep the remaining port plugged.
- ★2. Case drain port is available for use when draining hydraulic fluid from pump casing.
- ★3. Cable Applicable:
Outside Dia.....8-10 mm
Conductor Area.....Not Exceeding 1.5 mm²

Foot Mtg. : A70-LR04 * S

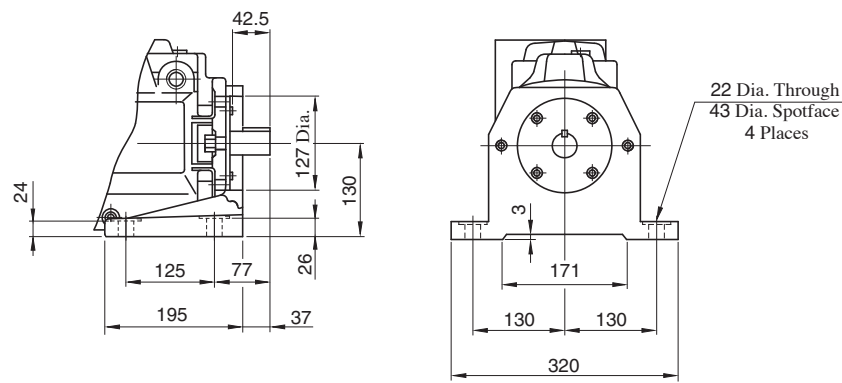

● For other dimensions, refer to "Flange Mtg.".

**Flange Mtg. : A90-FR04 * S
A100-FR04 * S**

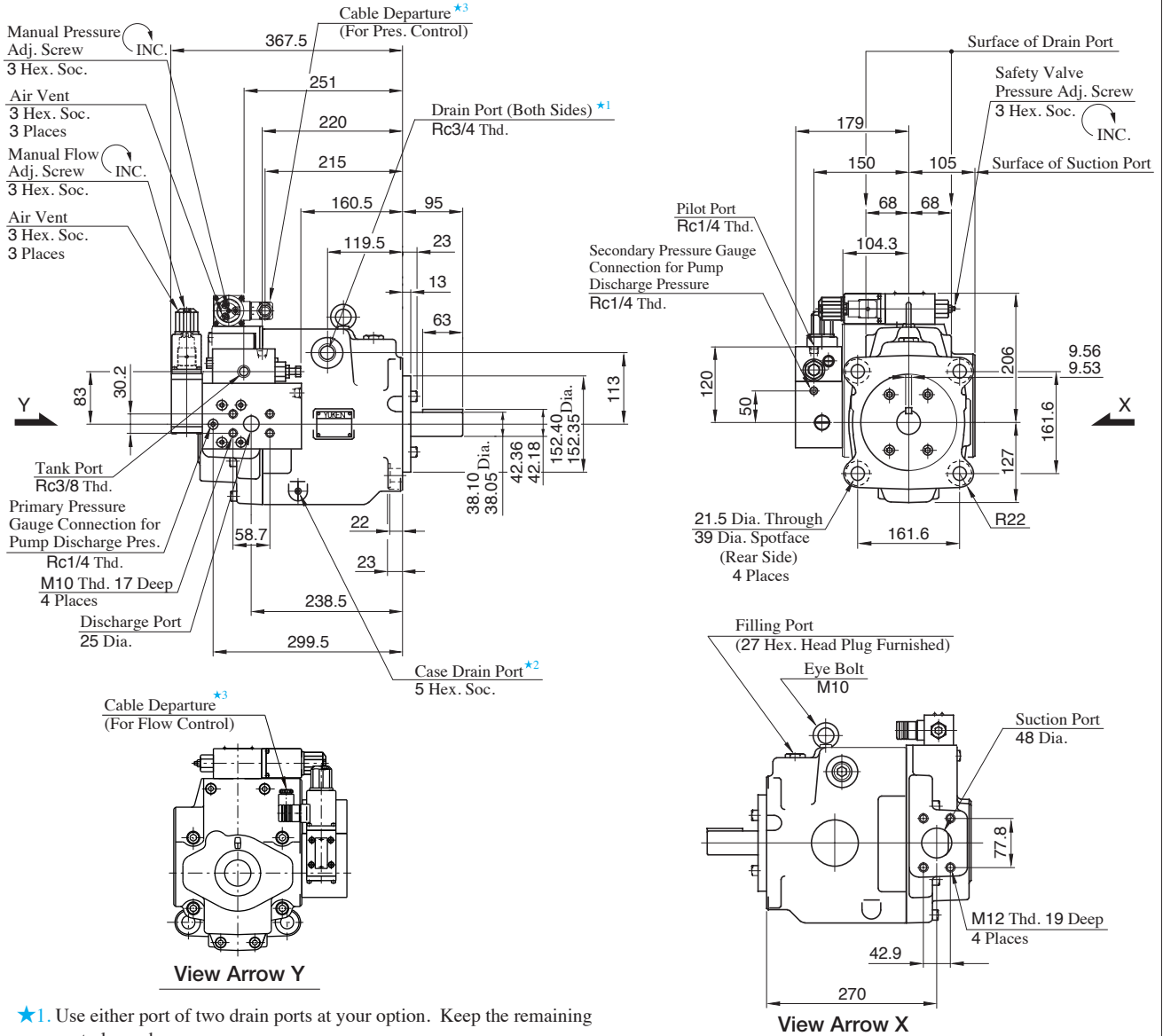

- ★1. Use either port of two drain ports at your option. Keep the remaining port plugged.
- ★2. Case drain port is available for use when draining hydraulic fluid from pump casing.
- ★3. Cable Applicable:
 Outside Dia.....8-10 mm
 Conductor Area.....Not Exceeding 1.5 mm²

Foot Mtg. : A90-LR04 * S

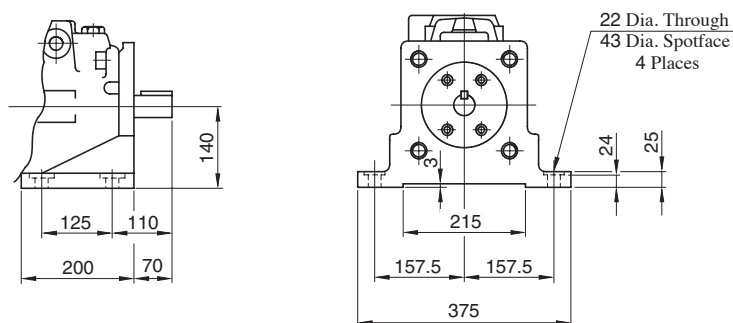

● For other dimensions, refer to "Flange Mtg.".

Flange Mtg. : A145-FR04 * S

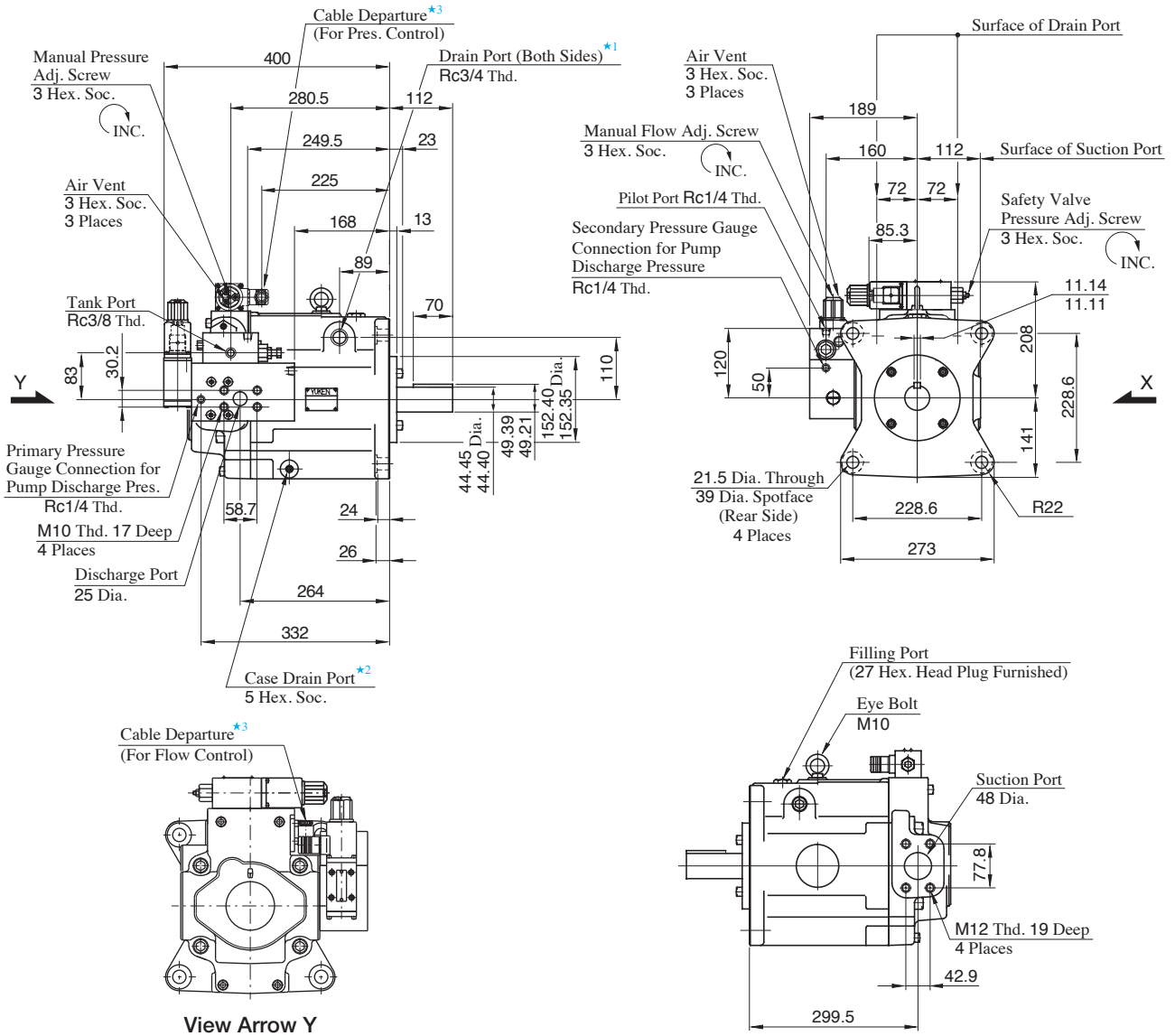

- ★1. Use either port of two drain ports at your option. Keep the remaining port plugged.
- ★2. Case drain port is available for use when draining hydraulic fluid from pump casing.
- ★3. Cable Applicable:
Outside Dia.....8-10 mm
Conductor Area.....Not Exceeding 1.5 mm²

Foot Mtg. : A145-LR04 * S

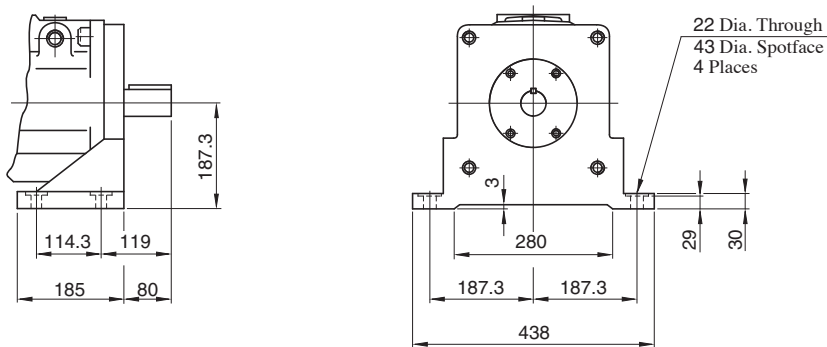

● For other dimensions, refer to "Flange Mtg.".

A Series Variable Displacement Piston Pumps, Electro-Hydraulic Proportional Pressure & Flow Control Type

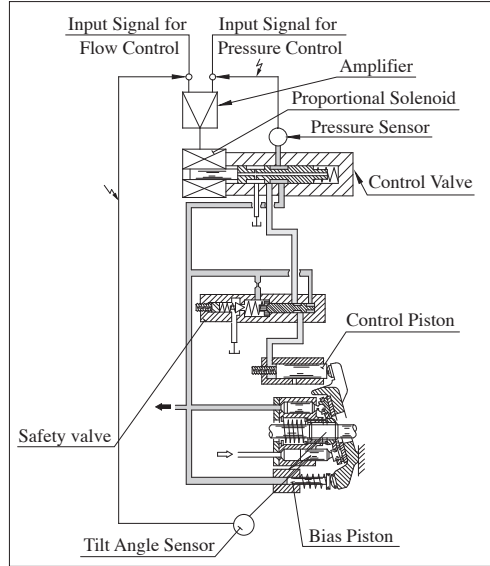
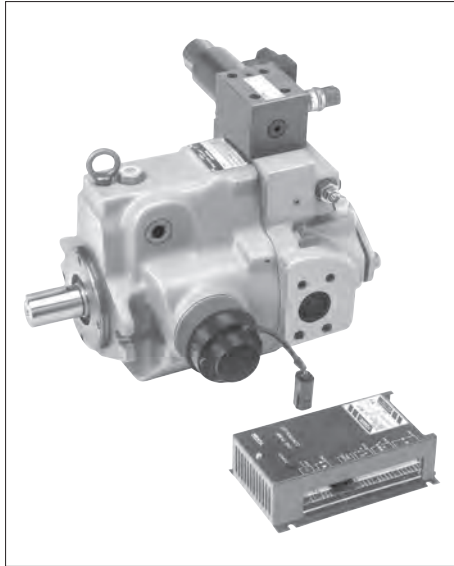

Performance Characteristics

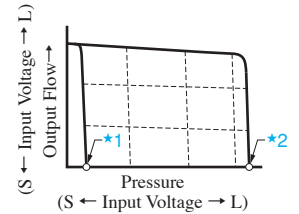

- ★1. Unloading pressure when input signal is 0 V.
- ★2. Safety valve setting pressure

Graphic Symbols

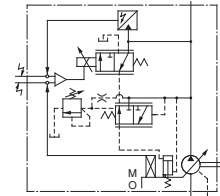

A16/A22/A37/A45/A56

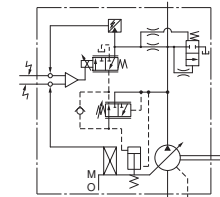

A70/A90/A100/A145

Model Number Designation

Series Number	Mounting	Direction of Rotation	Control Type	Control Pressure at Input Signal is 5 V	Type of Outboard Pump	Port Position	Compensation Number ^{★3}	Design Number
A45 (45.0 cm ³ /rev)	L: Foot Mtg. F: Flange Mtg.	R: Clockwise ^{★1} (Normal)	04E: Proportional Pressure & Flow Control Type	Use the same measure of the control pressure as shown on the right, 6.9 MPa specify within the range of maximum operating pressure	None ^{★2}	None : Axial Port S : Side Port	60	12
A16 (15.8 cm ³ /rev)						—	06	44
A22 (22.2 cm ³ /rev)						—	11	44
A37 (36.9 cm ³ /rev)						—	01	44
A56 (56.2 cm ³ /rev)						—	02	44
A70 (70.0 cm ³ /rev)						—	60	70
A90 (91.0 cm ³ /rev)						—	60	70
A100 (100 cm ³ /rev)						—	60	20
A145 (145 cm ³ /rev)						—	60	62

- ★1. Available to supply pump with anti-clockwise rotation. Consult Yuken for details.
- ★2. These pumps, except A16/A22/A45 types, can be connected to outboard pumps.
 - A37/A56 type (outboard pump connection symbol: **None**): spigot diameter: 82.55 mm (A16, A22, and PV2R1).
 - A70/A90/A100/A145 type (outboard pump connection symbol: **"A"**): spigot diameter: 82.55 mm (A16, A22, and PV2R1).
 - A70/A90/A100/A145 type (outboard pump connection symbol: **"B"**): spigot diameter: 101.6 mm (A37 and PV2R2).
- ★3. Amplifier compensation number may differ according to the main machine conditions. Consult Yuken for details.

Specifications

Descriptions		Model Numbers									
		A16	A22	A37	A45	A56	A70	A90	A100	A145	
Geometric Displacement		cm ³ /rev	15.8	22.2	36.9	45.0	56.2	70.0	91.0	100	145
Operating Pressure	MPa	Rated ^{*2}	16	16	16	16	16	25	25	21	25
		Intermittent ^{*1}	21	16	21	17.2	21	28	28	21	28
Shaft Speed Range		r/min	600 - 1800								
Flow Control	Max. Flow ^{*3}	L/min									
		50 Hz Pin	28.4	40.0	66.4	81.0	101	126	163	180	261
	60 Hz Pin	23.7	33.3	55.4	67.0	84.3	105	136	150	217	
	Min. Pres. Required for Flow Adj. MPa		2								
	Hysteresis		1 % or less								
Repeatability		1 % or less									
Input Signal		Max. Flow / 5 V DC									
Pressure Control	Min. Adjustment Pressure MPa		0.7								
	Hysteresis		1 % or less								
	Repeatability		1 % or less								
	Input Signal		Specified Control Pressure / 5 V DC								
Coil Resistance		Ω (@20°C)	10								
Input Impedance		Flow Control : 10 kΩ Pressure Control : 10 kΩ									
Supply Electric Power		24 V DC (21 - 28 V Included Ripple)									
Power Input (Max.)		W	30								
Output Signal	Flow		5 V DC / Max. Flow (50 Hz Pin)								
	Pressure		5 V DC / Specified Control Pressure								
Alarm Signal Output (Open Collector)		Voltage : Max. 30 V DC Current : Max. 40 mA									
Ambient Temperature		°C	0 - 50 (With Circulated Air)								
Approx. Mass	kg	Flange Mtg.	20.5	20.5	32	32	39	64	76.5	77.5	96.4
		Foot Mtg.	22.7	22.7	36.3	36.3	43.3	76	97	93	121.4

- ★1. Whenever setting pressure, make sure the full cut-off pressure never exceeds the maximum intermittent pressure.
- ★2. When operating the pump exceeding the rated pressure, operating conditions are restricted.
Refer to page A-28 for details.
- ★3. Maximum flow differs to shaft speed.
The value listed above indicates shaft speed of 1800 r/min.
For other shaft speed calculate by the ratio of shaft speed.

Pipe Flange Kits

Pipe flange kits are available. When ordering, specify the kit number from the table below.

Pump Model Numbers	Name of Port	Pipe Flange Kit Numbers		
		Threaded Connection	Socket Welding [★]	Butt Welding
A 16- *R04E A 22- *R04E	Suction	F5-06-A-10	F5-06-B-10	F5-06-C-10
	Discharge	F5-06-A-10	F5-06-B-10	F5-06-C-10
A 37- *R04E A 45- *R04E A 56- *R04E	Suction	F5-10-A-10	F5-10-B-10	F5-10-C-10
	Discharge	F5-10-A-10	F5-10-B-10	F5-10-C-10
A 70- *R04E	Suction	F5-12-A-10	F5-12-B-10	F5-12-C-10
	Discharge	F5-08-A-10	F5-08-B-10	F5-08-C-10
A 90- *R04E A100- *R04E A145- *R04E	Suction	F5-16-A-10	F5-16-B-10	F5-16-C-10
	Discharge	F5-10-A-10	F5-10-B-10	F5-10-C-10

- ★ In case of using socket welding flanges, there is a case where the operating pressure should be set lower than the normal because of strength of the flanges. Therefore, please pay cautious attention to the operating pressure when the socket welding flanges are used.
- Details of the pipe flange kits are shown on pages A-258 and A-259.

Output Flow vs. Input Signal

● A16

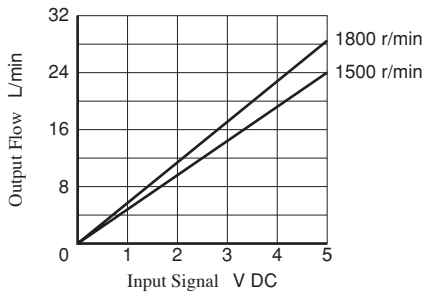

● A56

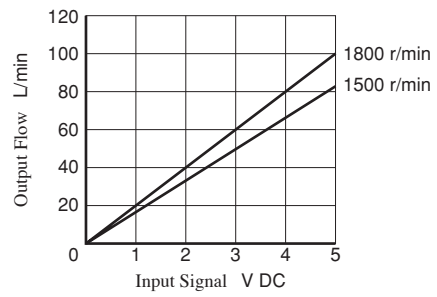

● A22

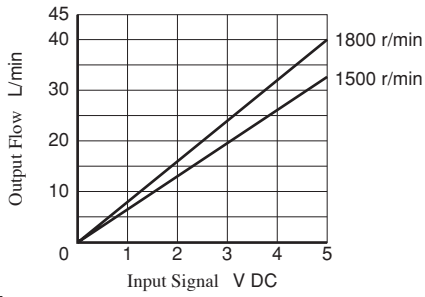

● A70

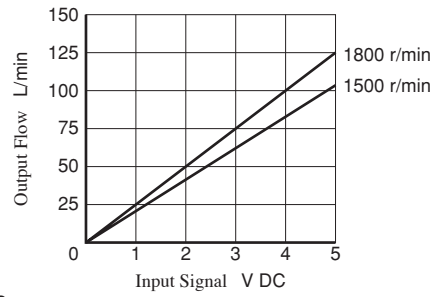

● A37

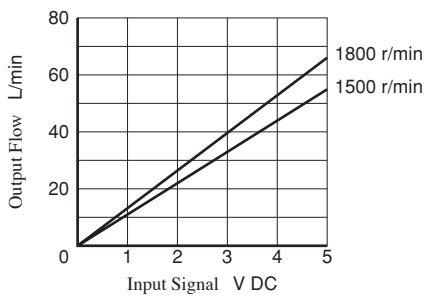

● A90

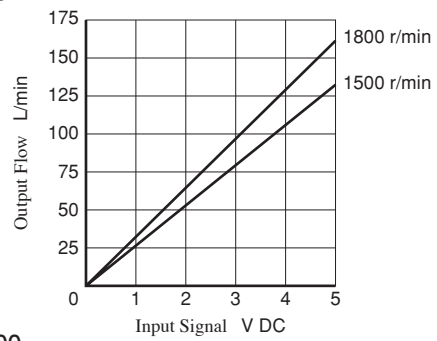

● A45

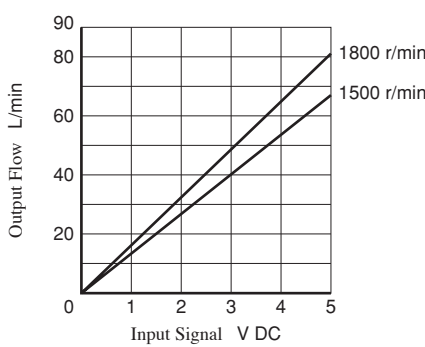

● A100

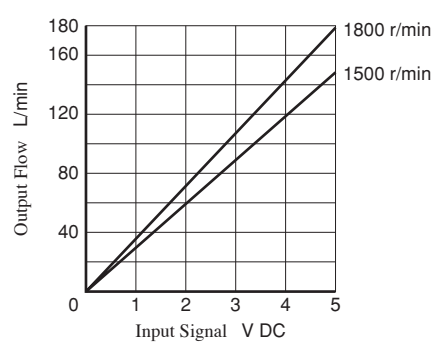

● A145

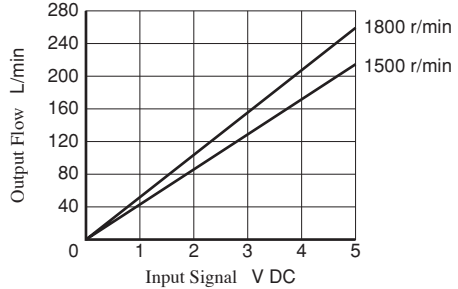

Full Cut-off Pres. vs. Input Signal

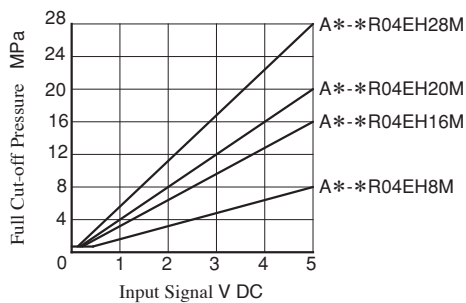

Refer to page A-32 to A-40 for performance characteristics of pressure compensator type excluding characteristics appeared on this catalogue.

Flange Mtg. : A16-FR04E * A22-FR04E *

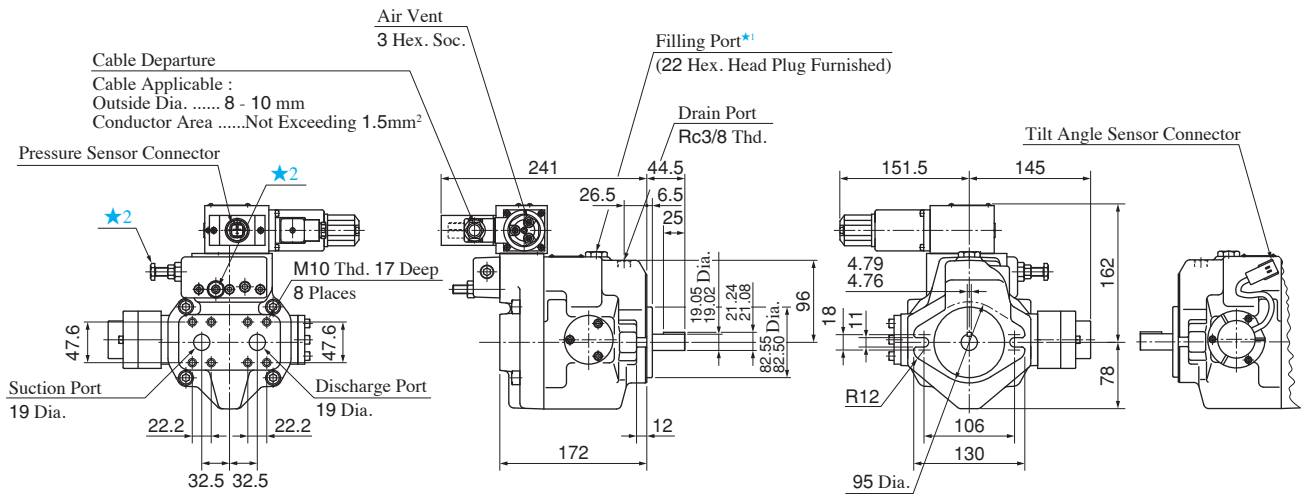

- ★1. Install the pump so that the “Filling Port” is at the top.
- ★2. Do not touch the screw because it is adjusted at the time of shipment.
- ★3. For cable connection with amplifiers, see page A-78.

● Foot Mounting Type

Mounting bracket is common to that of pressure compensator model.
Refer to page A-42 for the dimensions of mounting bracket.

Flange Mtg. : A37-FR04E *

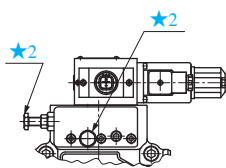
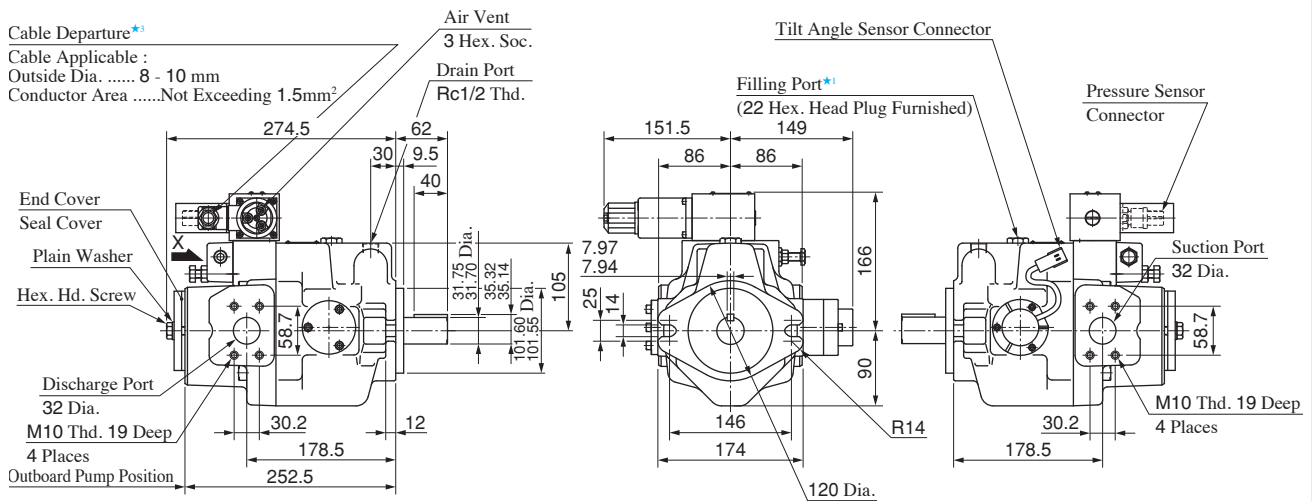

View Arrow X

- ★1. Install the pump so that the “Filling Port” is at the top.
- ★2. Do not touch the screw because it is adjusted at the time of shipment.
- ★3. For cable connection with amplifiers, see page A-78.

● Foot Mounting Type

Mounting bracket is common to that of pressure compensator model.
Refer to page A-43 for the dimensions of mounting bracket.

Axial Port Type

Flange Mtg. : A45-FR04E *

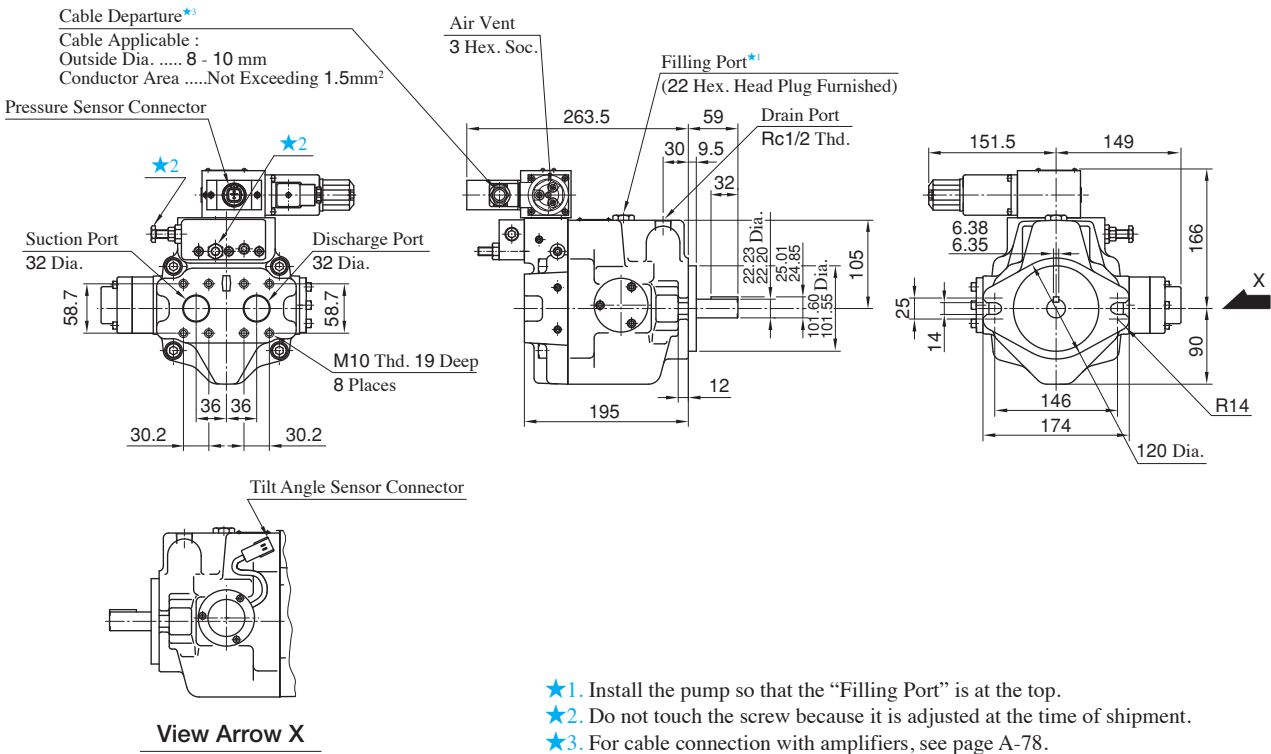

Side Port Type

Flange Mtg. : A45-FR04E * S

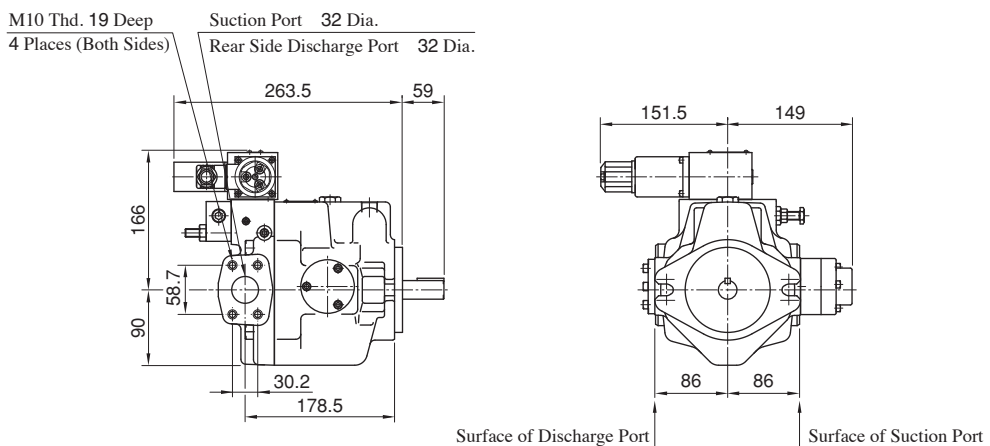

● For other dimensions, refer to “Axial Port Type”.

● **Foot Mounting Type**

Mounting bracket is common to that of pressure compensator model.
 Refer to page A-43 for the dimensions of mounting bracket.

Flange Mtg. : A56-FR04E *

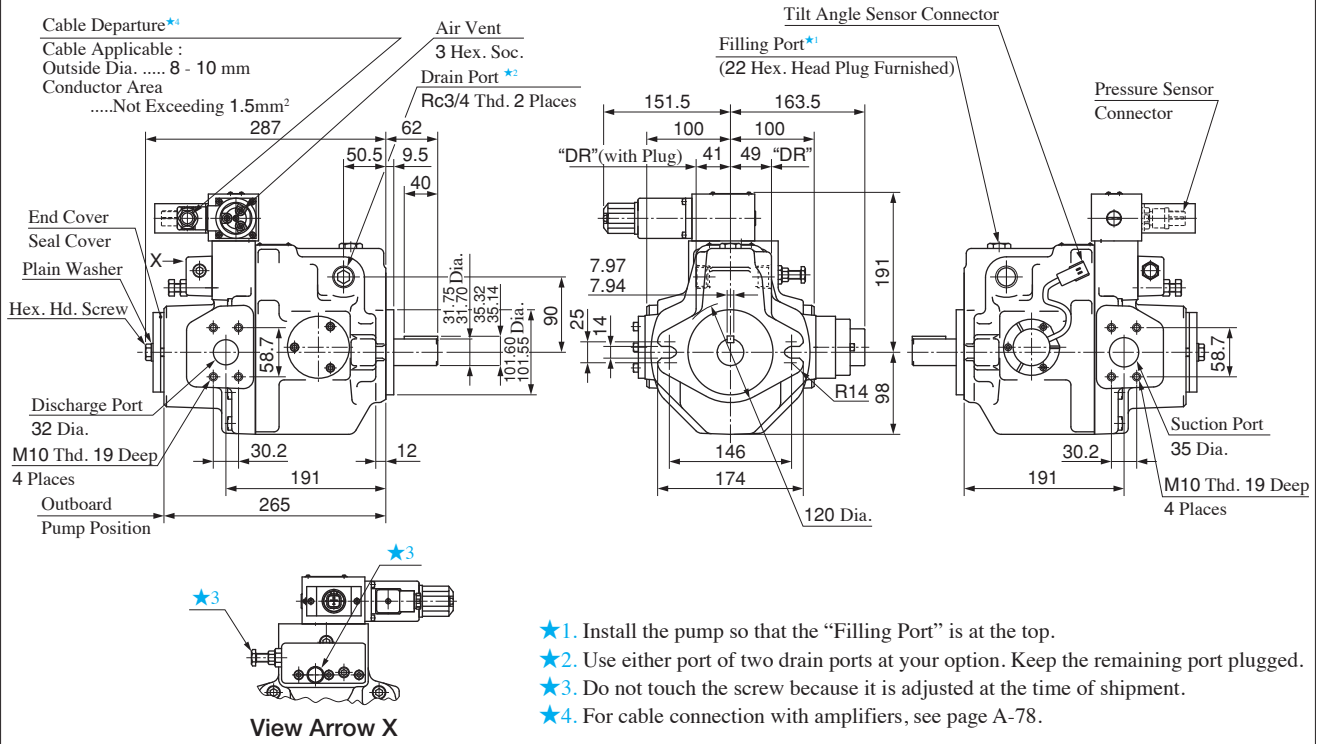

● Foot Mounting Type

Mounting bracket is common to that of pressure compensator model.
 Refer to page A-44 for the dimensions of mounting bracket.

Flange Mtg. : A70-FR04E *

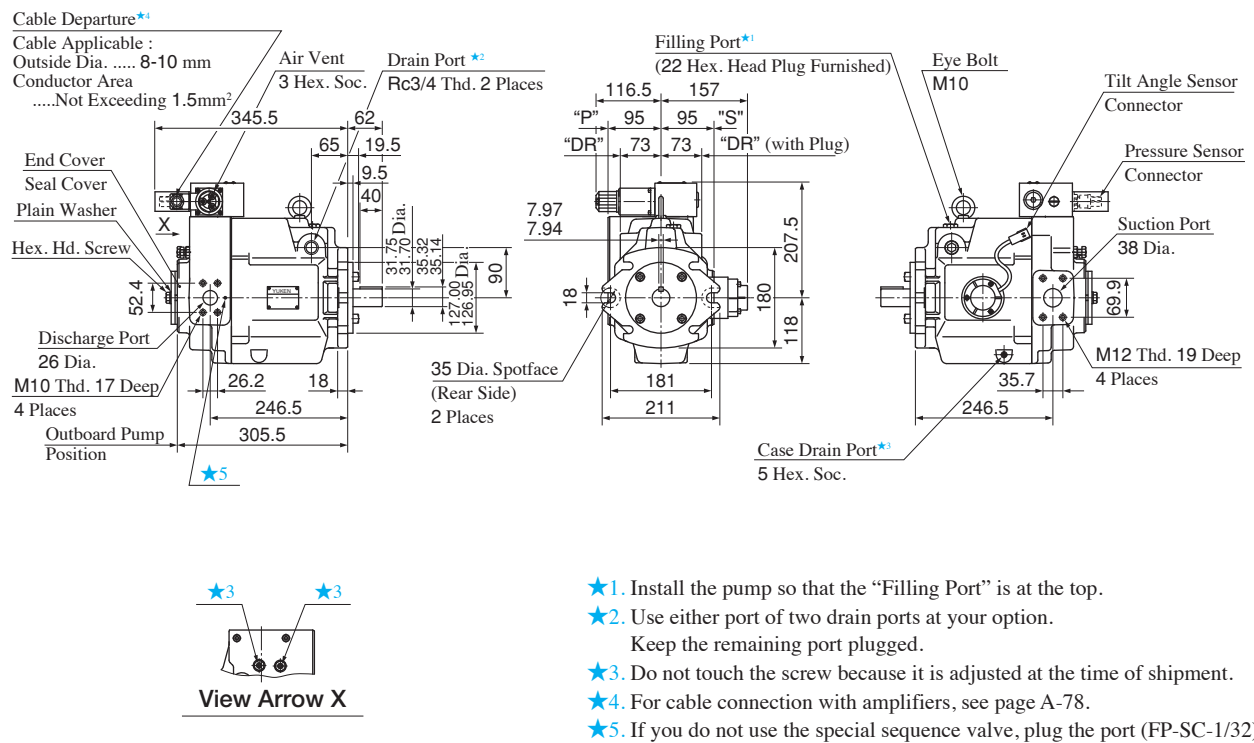

● Foot Mounting Type

Mounting bracket is common to that of pressure compensator model.
 Refer to page A-45 for the dimensions of mounting bracket.

**Flange Mtg. : A90-FR04E **
A100-FR04E ****

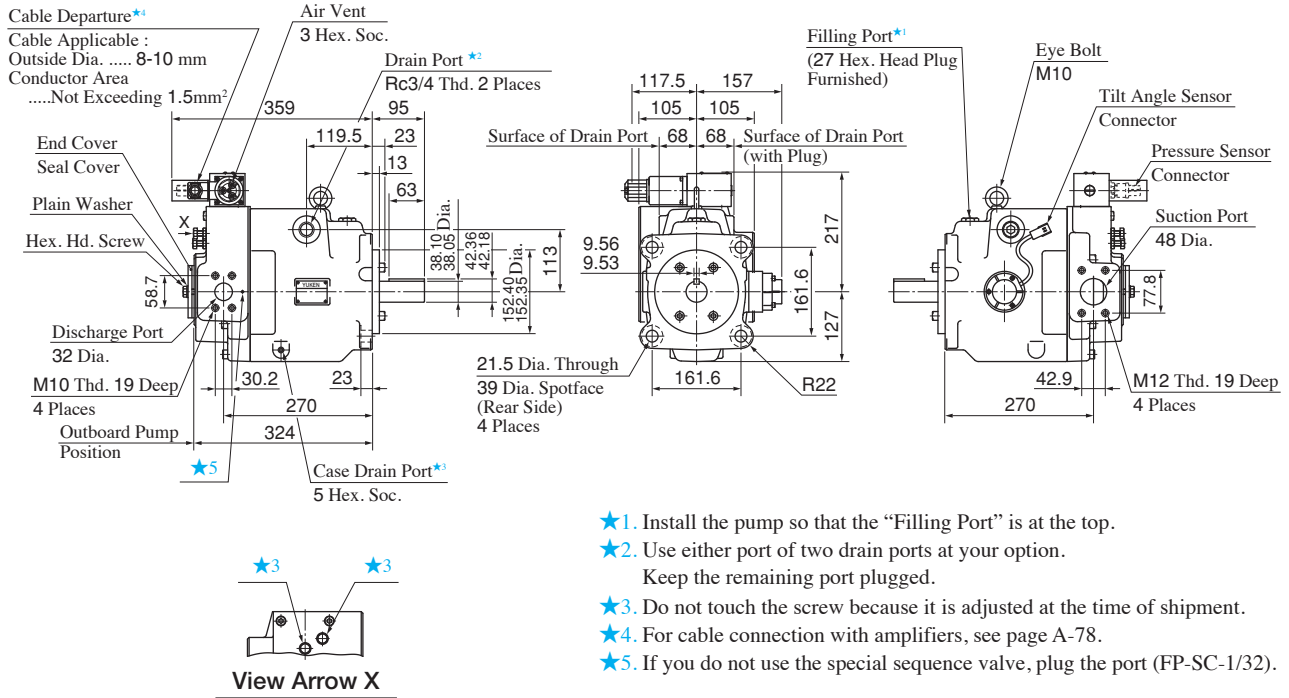

- ★¹. Install the pump so that the "Filling Port" is at the top.
- ★². Use either port of two drain ports at your option. Keep the remaining port plugged.
- ★³. Do not touch the screw because it is adjusted at the time of shipment.
- ★⁴. For cable connection with amplifiers, see page A-78.
- ★⁵. If you do not use the special sequence valve, plug the port (FP-SC-1/32).

● **Foot Mounting Type**

Mounting bracket is common to that of pressure compensator model.
Refer to page A-46 for the dimensions of mounting bracket.

Flange Mtg. : A145-FR04E **

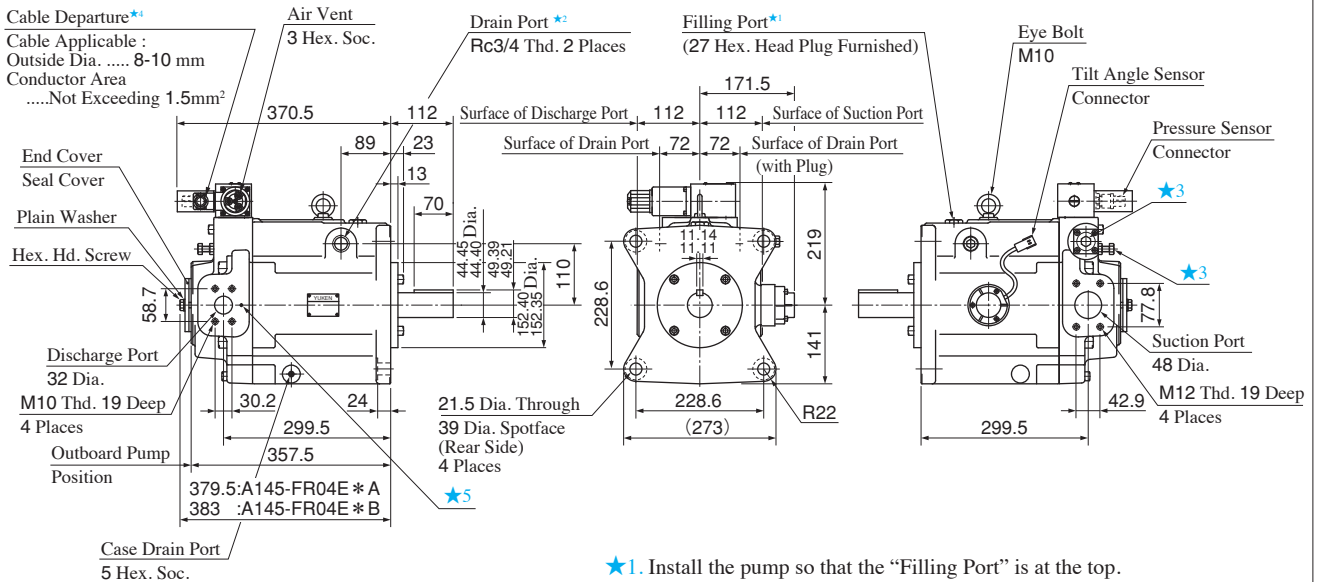

- ★¹. Install the pump so that the "Filling Port" is at the top.
- ★². Use either port of two drain ports at your option. Keep the remaining port plugged.
- ★³. Do not touch the screw because it is adjusted at the time of shipment.
- ★⁴. For cable connection with amplifiers, see page A-78.
- ★⁵. If you do not use the special sequence valve, plug the port (FP-SC-1/32).

● **Foot Mounting Type**

Mounting bracket is common to that of pressure compensator model.
Refer to page A-47 for the dimensions of mounting bracket.

Amplifiers for Electro-Hydraulic Proportional Pressure & Flow Control Type Pumps

SK1106-★-*-*-11**

Specifications

Model No.	SK1106-★-*-*-11**
Descriptions	
Applicable Coil Resistance	10 Ω (20°C)
Input Impedance	10 kΩ (PIN, QIN)
Power Supply	24 V DC (21 - 28 V Included Ripple)
Power Input (Max.)	30 W
Input Signal	Max. Flow / 5 V (QIN) Specified Pres. / 5 V (PIN)
Output Signal for Sensor Monitor	5 V / Max. Flow (SMQ) 5 V / Specified Pres. (SMP)
Ambient Temperature	0 - 50 °C
Approx. Mass	450 g

Detail of Connector

Connector	Name of Signal	
CN1 Solenoid	1	Output to pilot valve solenoid
	2	
CN2 Power Supply	1	0 [V] (0 V)
	2	+24 [V] (24 V)
	3	0 [V]
CN3 Pres. Sensor	1	+5 [V] rowspan="2">Power Supply for Sensor
	2	0 [V]
	3	Input Signal - Sensor
	4	0 [V]
CN4 Tilt Angle Sensor	1	+8 [V] rowspan="2">Power Supply for Sensor
	2	0 [V]
	3	Input Signal - Sensor
	4	0 [V]
	5	—
CN5 Input/Output Signal	1	Input Signal - Flow (Qin)
	2	Input Signal - Common (COM)
	3	Input Signal - Pres. (Pin)
	4	Output Signal - Sensor Monitor P (SMP)
	5	Output Signal - Sensor Monitor Q (SMQ)
	6	0 [V]

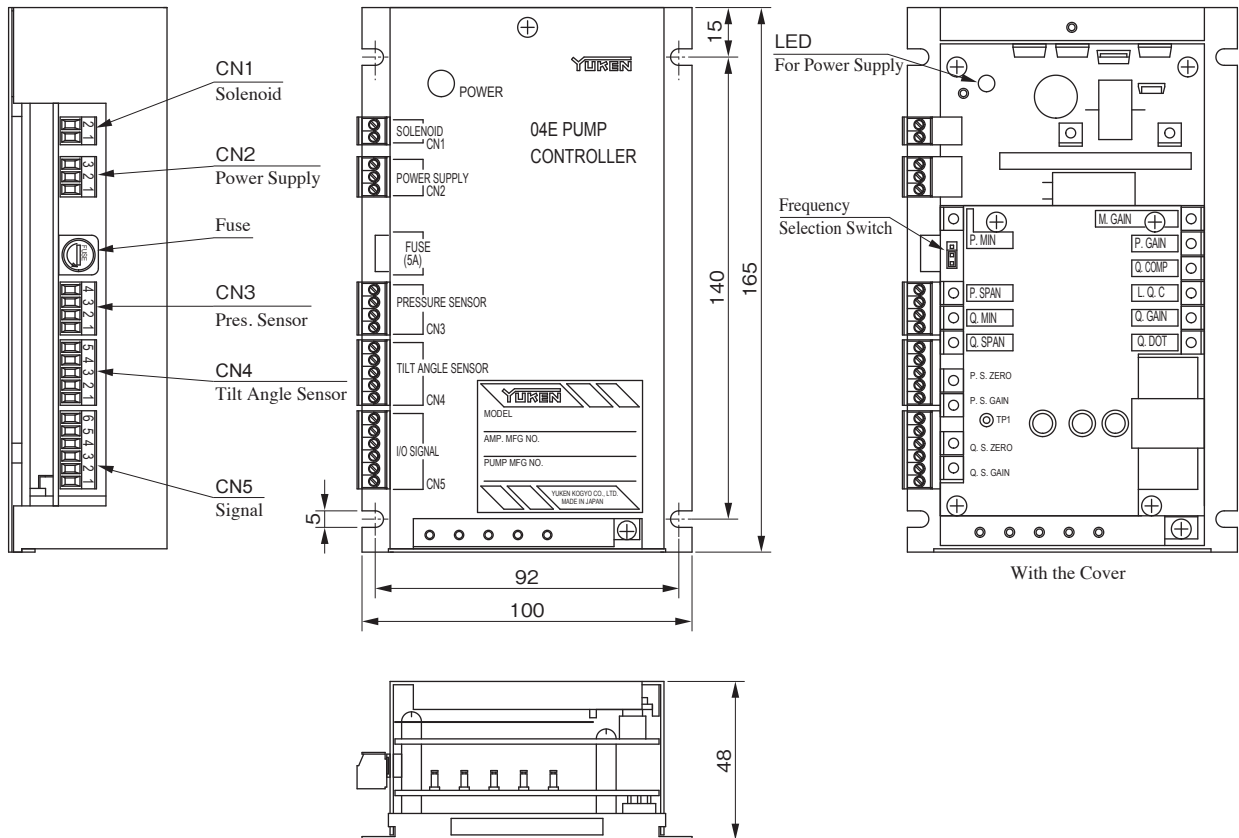

■ Cable Connection Between Pump and Amplifier

The cable connections between the proportional pilot valve and the sensor of the pump and the attached amplifier (SK1106) are shown below.

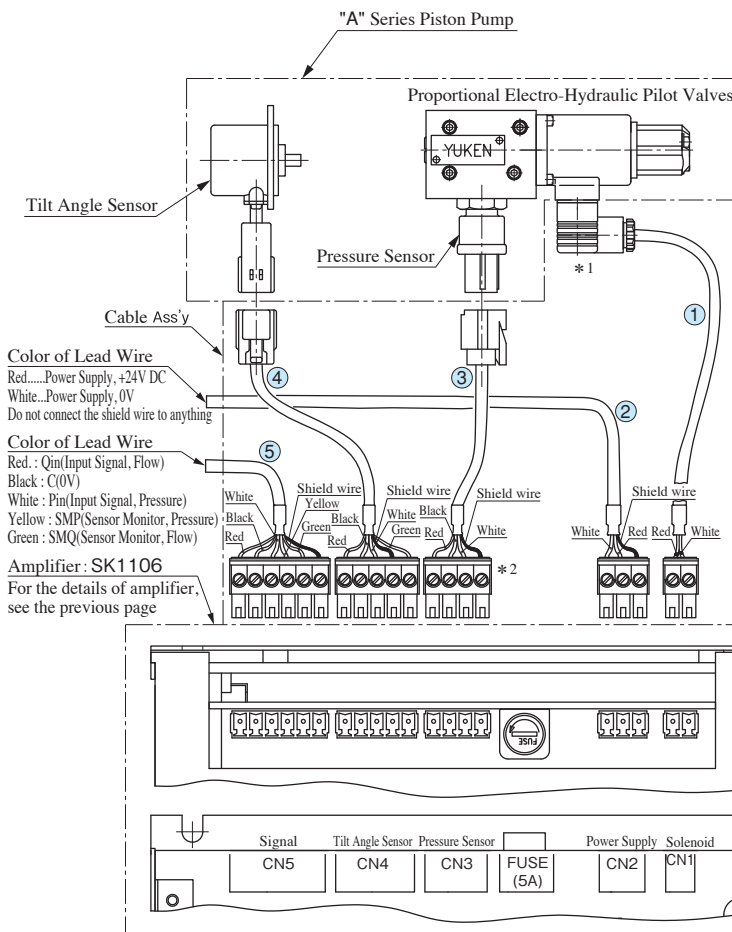

■ Detail of Connector (Pump Side)

1. Pressure Sensor (HW090 connector 3-Pin (T-type) Sumitomo Wiring Systems, Ltd.)



Terminals No.

1. Power Supply (Color of mating connector Ass'y lead : Red)
2. Output (Color of mating connector Ass'y lead : White)
3. 0V (Color of mating connector Ass'y lead : Black)

2. Tilt Angle Sensor (J series connector<Mark II> 4-pin(174259-2) TE connectivity)



Terminals No.

1. Power Supply (Color of mating connector Ass'y lead : Red)
2. 0V (Color of mating connector Ass'y lead : Black)
3. Output (Color of mating connector Ass'y lead : White)
4. Shield wire

3. Solenoid (GDM-211-B-11:YUKEN)



Terminals No.

1. SOL Input (Color of mating connector Ass'y Lead : Red)
2. SOL Input (Color of mating connector Ass'y lead : White)
3. Not Used

■ Connector For Cable Ass'y

● Amplifier Side

MC1.5/*-ST-3.81
(Phoenix Contact)

● Sensor Side

1. Pressure Sensor
Type:HW090
Housing : F (6189-0131)
Retainer : F (6918-0326)
Terminal : F (1500-0106)
Wire seal : S (7165-0118)
(Sumitomo Wiring Systems, Ltd.)

2. Tilt Angle Sensor
Type : J Series
Connector<Mark II>
4-pin : (174257-2)
(TE connectivity)

★1. Cable assemblies are available. When ordering, specify the cable Ass'y model numbers from the table below.

Name of Cable Ass'y	Cable Ass'y Model Numbers					
	Approx. Length of Cable (mm)					
	2000	5000	10000	15000	20000	25000
① For Solenoid	SK1112-S-2-11	SK1112-S-5-11	SK1112-S-10-11	SK1112-S-15-11	SK1112-S-20-11	SK1112-S-25-11
② For Power Supply	SK1112-V-2-11	SK1112-V-5-11	SK1112-V-10-11	SK1112-V-15-11	SK1112-V-20-11	SK1112-V-25-11
③ For Pressure Sensor	SK1112-P-2-11	SK1112-P-5-11	SK1112-P-10-11	SK1112-P-15-11	SK1112-P-20-11	SK1112-P-25-11
④ For Tilt Angle Sensor	SK1112-Q-2-11	SK1112-Q-5-11	SK1112-Q-10-11	SK1112-Q-15-11	SK1112-Q-20-11	SK1112-Q-25-11
⑤ For Signal	SK1112-C-2-11	SK1112-C-5-11	SK1112-C-10-11	SK1112-C-15-11	SK1112-C-20-11	SK1112-C-25-11

★2. *1 connector for the solenoid (GDM-211-B-11) and *2 connectors for amplifier (MC1.5/*-ST-3.81) are already attached to the pump and the amplifier, respectively. If using the cable Ass'y, remove every attached connector before wiring.

Series Variable Displacement Piston Pumps, "OBE" Type Electro-Hydraulic Proportional Pressure & Flow Control Type

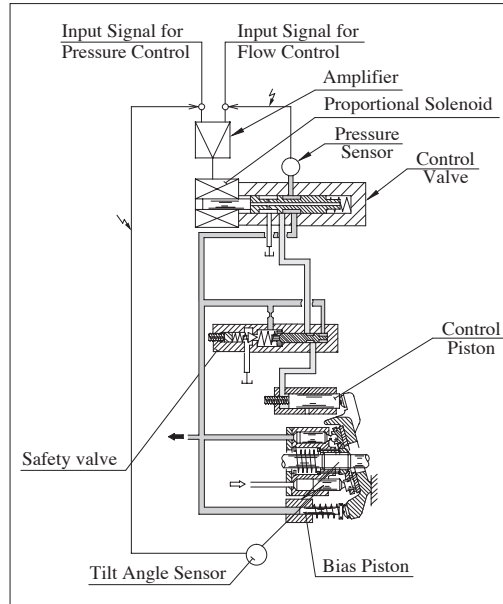

Performance Characteristics

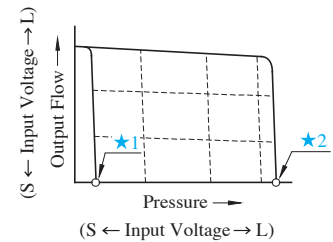

- ★1. Unloading pressure when input signal is 0 V.
- ★2. Safety valve setting pressure

Graphic Symbols

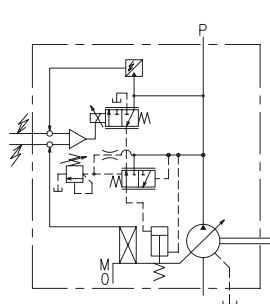

A16/A22/A37/A56

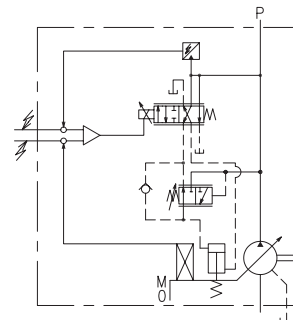

A70/A90/A145

Model Number Designation

A70	-F	R	04EH	16M	R	S	-60	44
Series Number	Mounting	Direction of Rotation	Control Type	Pressure Control Level	Amplifier Direction	Port Position	Compensation Number★2	Design Number
A16 (15.8 cm ³ /rev)	F: Flange Mtg.	(Viewed from Shaft End)	04EH: "OBE" Type Proportional Pressure & Flow Control Type	Specify Control Pressure between 6.9 MPa and Maximum Operating Pressure (Example) 16M:16 MPa	—	None: Axial Port S: Side Port	06	44
A22 (22.2 cm ³ /rev)							11	44
A37 (36.9 cm ³ /rev)							01	44
A56 (56.2 cm ³ /rev)							02	44
A70 (70.0 cm ³ /rev)	L: Foot Mtg.	R: Clockwise★1 (Normal)			(Viewed from Shaft End) R: Right L: Left	S: Side Port	60	70
A90 (91.0 cm ³ /rev)							60	70
A145 (145 cm ³ /rev)							60	62

★1. Available to supply pump with anti-clockwise rotation. Consult Yuken for details.
 ★2. Amplifier Compensation Number may differ according to the main machine conditions. Consult Yuken for details.

Specifications

Descriptions		Model Numbers							
		A16	A22	A37	A56	A70	A90	A145	
Geometric Displacement		cm ³ /rev	15.8	22.2	36.9	56.2	70.0	91.0	145.0
Operating Pressure	MPa	Rated ^{★2}	16	16	16	16	25	25	25
		Intermittent ^{★1}	21	16	21	21	28	28	28
Shaft Speed Range		r/min	600 - 1800						
Flow Control	Max. Flow ^{★2}	L/min	28.4	40.0	66.4	101.2	126.0	163.0	261.0
	Min. Pres. Required for Flow Adj.	MPa	2.0						
	Hysteresis		1 % or less						
	Repeatability		1 % or less						
	Input Signal		Max. Flow / 5 V DC						
Pressure Control	Min. Adjustment Pressure	MPa	0.7						
	Hysteresis		1 % or less						
	Repeatability		1 % or less						
	Input Signal		Specified Control Pressure / 5 V DC						
Coil Resistance		Ω [@ 20°C]	10						
Input Impedance			Flow Control : 10 kΩ Pres. Control : 10 kΩ						
Supply Electric Power			24 V DC (21 - 28 V Included Ripple)						
Power Input (Max.)		W	30						
Output Signal	Flow		5 V DC / Max. Flow						
	Pressure		5 V DC / Specified Control Pressure						
Alarm Signal Output (Open Collector)			Voltage : Max. 30 V DC Current : Max. 40 mA						
Ambient Temperature		°C	0 - 50 (With Circulated Air)						
Mass	kg	Flange Mtg.	20.7	20.7	32.2	39.2	64	76.5	98
		Foot Mtg.	22.9	22.9	36.5	43.5	76	97	123

- ★1. Whenever setting pressure, make sure the full cut-off pressure never exceeds the maximum intermittent pressure.
- ★2. When operating the pump exceeding the rated pressure, operating conditions are restricted.
Refer to page A-28 for details.
- ★3. Maximum flow differs to shaft speed.
The value listed above indicates shaft speed of 1800 r/min.
For other shaft speed calculate by the ratio of shaft speed.

Pipe Flange Kits

For pipe flange, refer to form of pressure compensator type on page A-29.

Output Flow vs. Input Signal

● A16

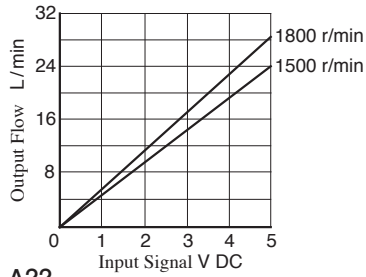

● A56

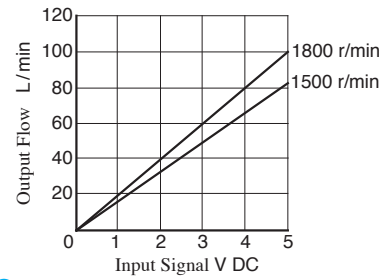

● A22

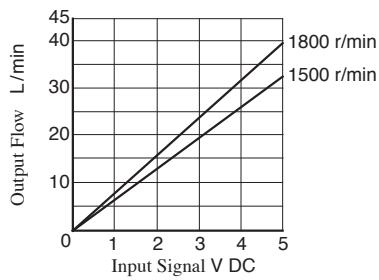

● A70

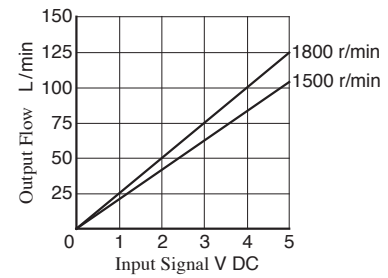

● A37

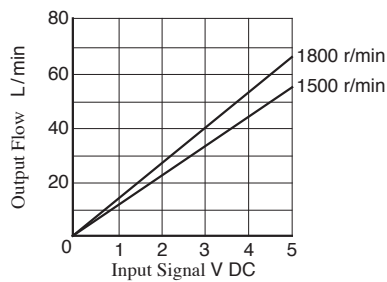

● A90

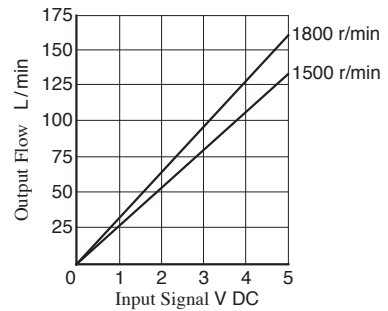

● A145

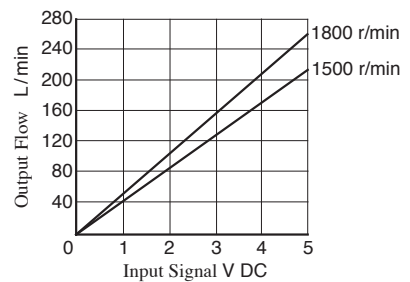

Full Cut-off Pres. vs. Input Signal

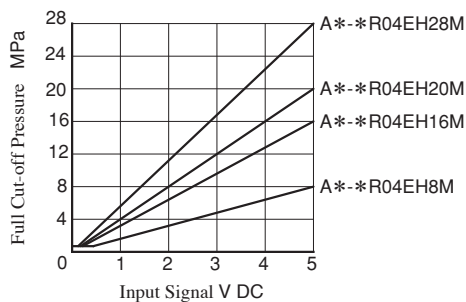

Refer to pages A-32 to A-34, A-36 to A-38 and A-40 for performance characteristics of pressure compensator type excluding characteristics appeared on this catalogue.

Axial Port Type

**Flange Mtg. : A16-FR04EH *
A22-FR04EH ***

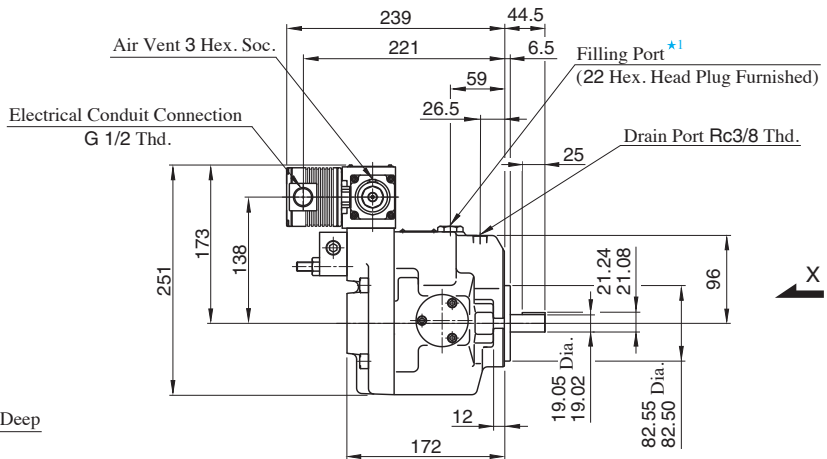
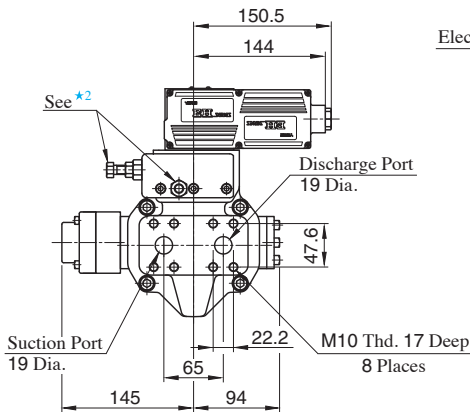

- ★1. Install the pump so that the "Filling Port" is at the top.
- ★2. Do not touch the screw because it is adjusted at the time of shipment.
- ★3. For detail of amplifier, refer to page A-87.

● Side Port Type

Port mounting dimensions are the same as those of pressure compensator model. Refer to page A-42 for port mounting dimensions.

● Foot Mounting Type

Mounting bracket is common to that of pressure compensator model. Refer to page A-42 for the dimensions of mounting bracket.

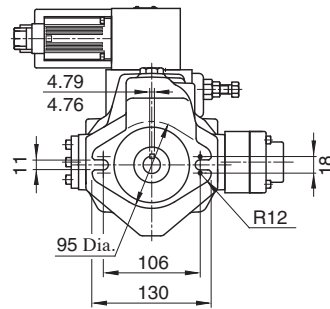

View Arrow X

Axial Port Type

Flange Mtg. : A37-FR04EH *

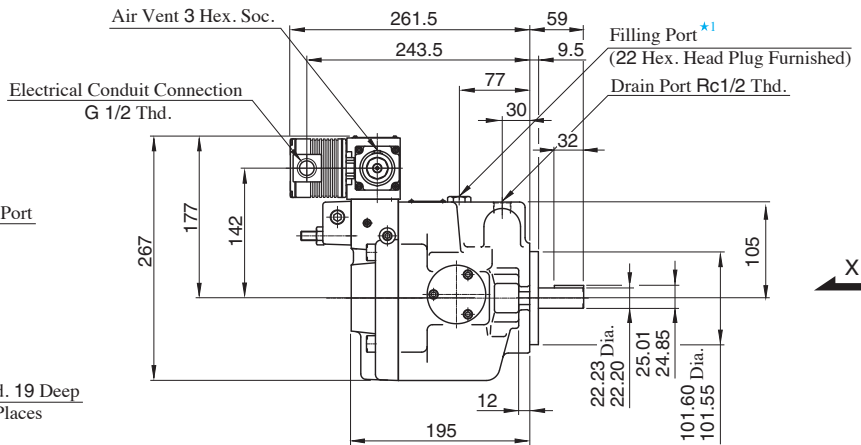
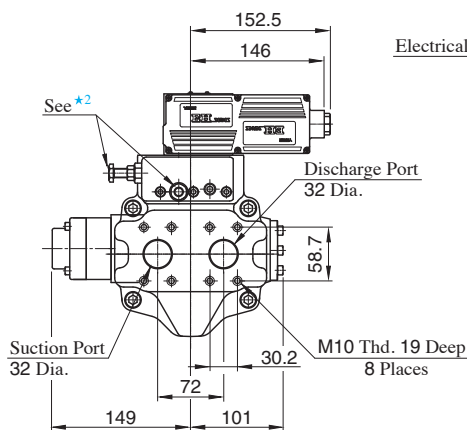

- ★1. Install the pump so that the "Filling Port" is at the top.
- ★2. Do not touch the screw because it is adjusted at the time of shipment.
- ★3. For detail of amplifier, refer to page A-87.

● Side Port Type

Port mounting dimensions are the same as those of pressure compensator model. Refer to page A-43 for port mounting dimensions.

● Foot Mounting Type

Mounting bracket is common to that of pressure compensator model. Refer to page A-43 for the dimensions of mounting bracket.

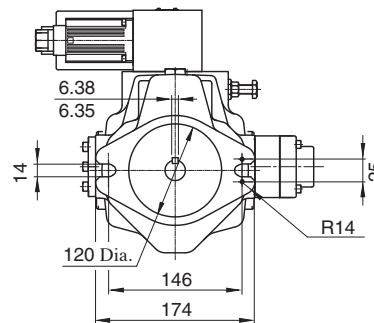

View Arrow X

Axial Port Type

Flange Mtg. : A56-FR04EH *

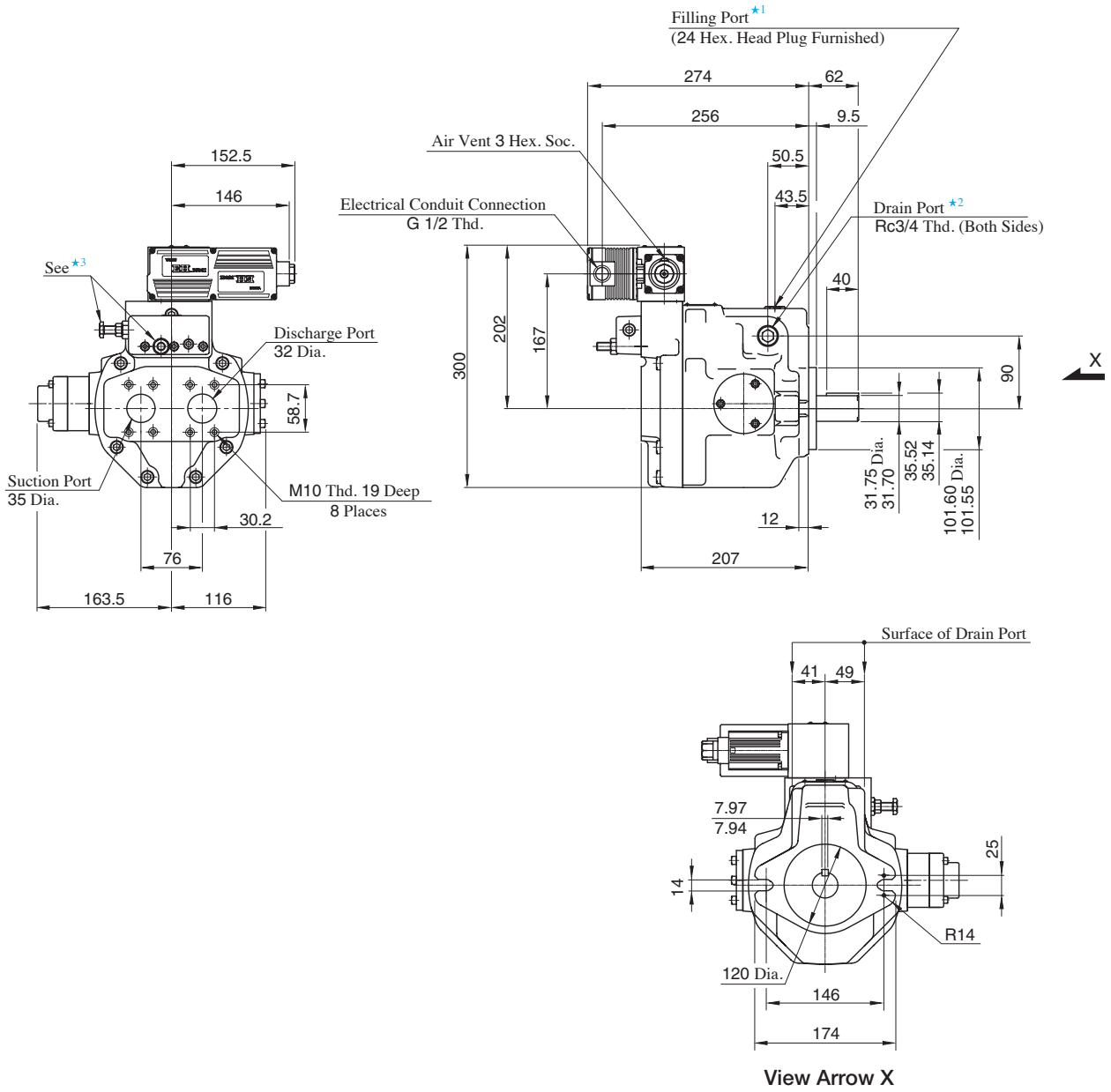

- ★1. Install the pump so that the "Filling Port" is at the top.
- ★2. Use either port of two drain ports at your option. Keep the remaining port plugged.
- ★3. Do not touch the screw because it is adjusted at the time of shipment.
- ★4. For detail of amplifier, refer to page A-87.

● Side Port Type

Port mounting dimensions are the same as those of pressure compensator model. Refer to page A-44 for port mounting dimensions.

● Foot Mounting Type

Mounting bracket is common to that of pressure compensator model. Refer to page A-44 for the dimensions of mounting bracket.



Flange Mtg.

◦ Amplifier Direction "L" : A70-FR04EH *LS

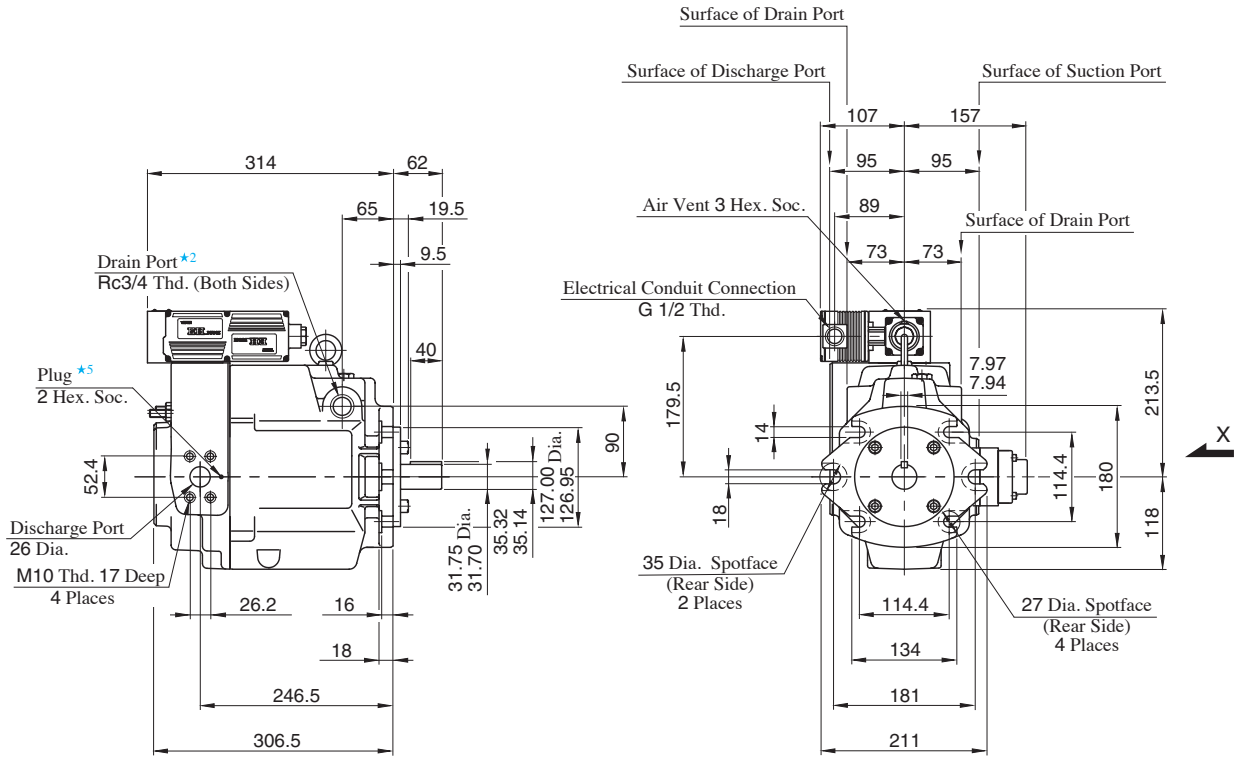

◦ Amplifier Direction "R": A70-FR04EH *RS

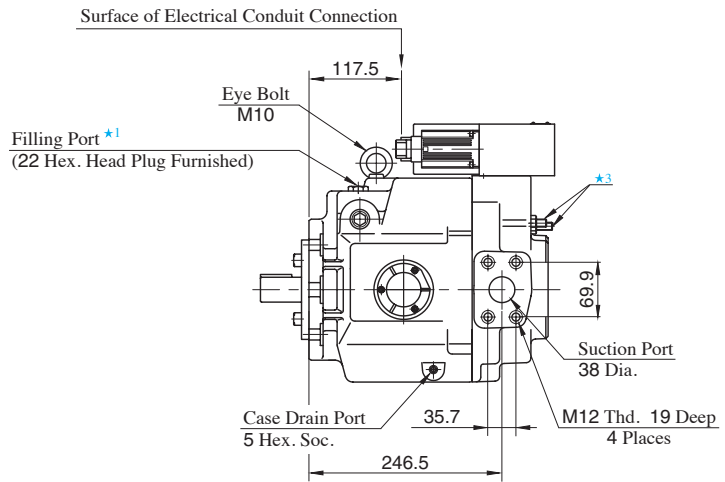
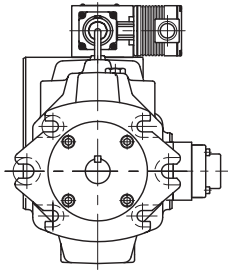

View Arrow X

- ★1. Install the pump so that the "Filling Port" is at the top.
- ★2. Use either port of two drain ports at your option. Keep the remaining port plugged.
- ★3. Do not touch the screw because it is adjusted at the time of shipment.
- ★4. For detail of amplifier, refer to page A-87.
- ★5. If you use the special sequence valve, remove the plug.

● Foot Mounting Type

Mounting bracket is common to that of pressure compensator model.
Refer to page A-45 for the dimensions of mounting bracket.

Flange Mtg.

- Amplifier Direction "L" : A90-FR04EH *LS

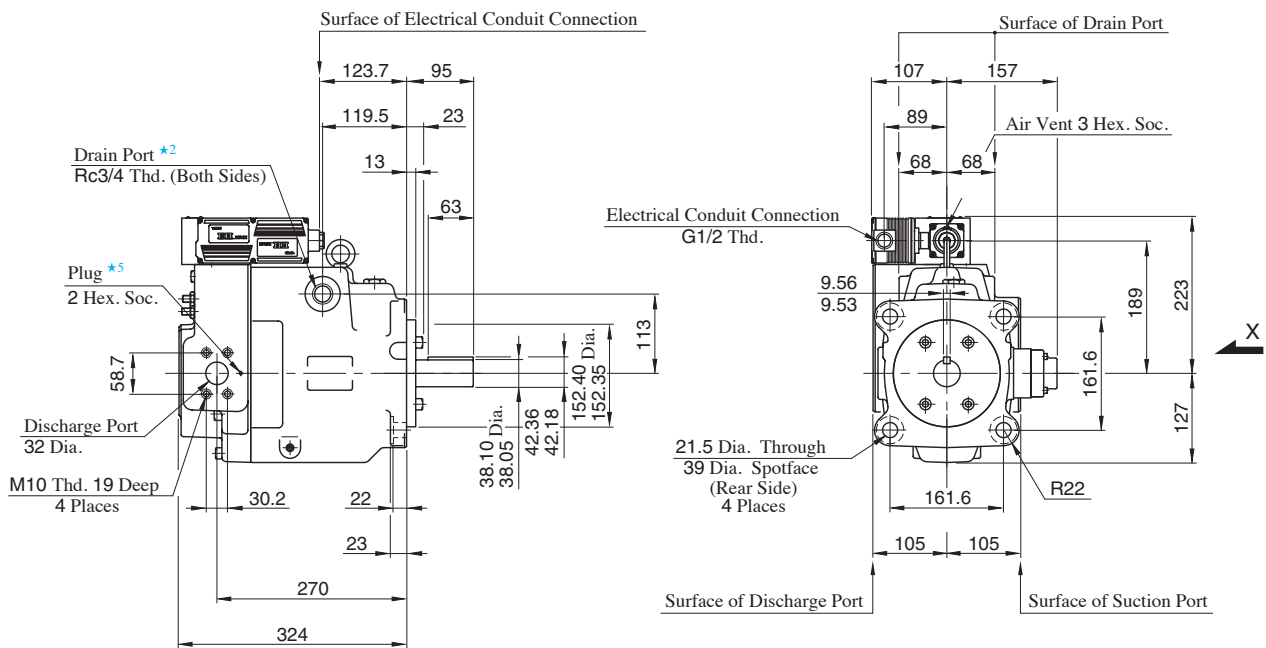

- Amplifier Direction "R": A90-FR04EH *RS

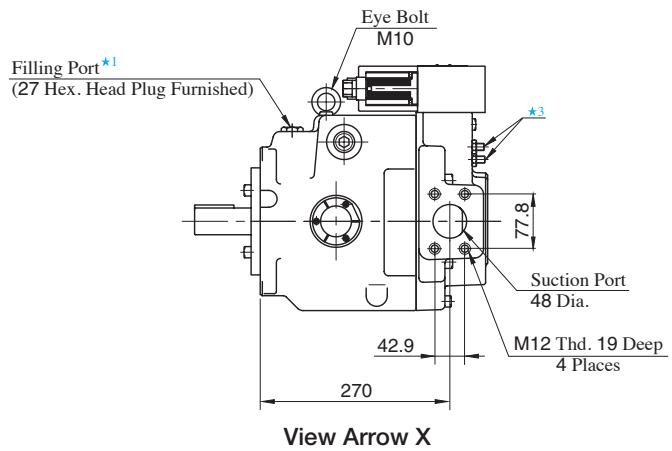
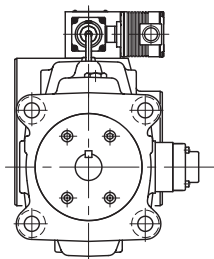

- ★1. Install the pump so that the "Filling Port" is at the top.
- ★2. Use either port of two drain ports at your option. Keep the remaining port plugged.
- ★3. Do not touch the screw because it is adjusted at the time of shipment.
- ★4. For detail of amplifier, refer to page A-87.
- ★5. If you use the special sequence valve, remove the plug.

● Foot Mounting Type

Mounting bracket is common to that of pressure compensator model.
Refer to page A-46 for the dimensions of mounting bracket.

Flange Mtg.

◦ Amplifier Direction "L" : A145-FR04EH *LS

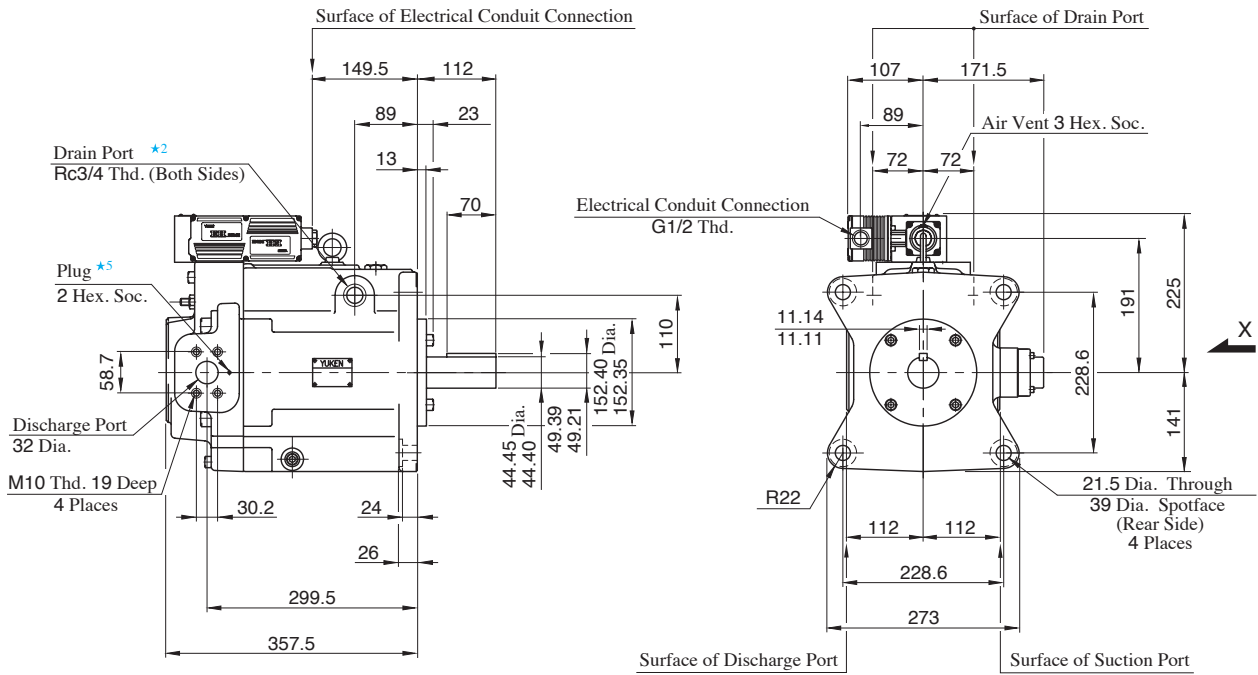

◦ Amplifier Direction "R": A145-FR04EH *RS

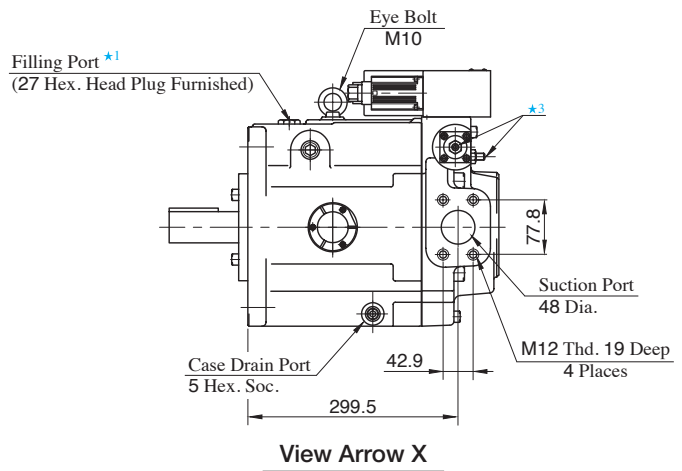
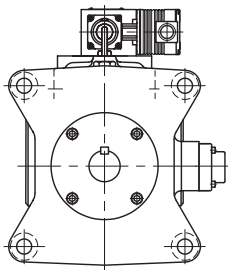

- ★1. Install the pump so that the "Filling Port" is at the top.
- ★2. Use either port of two drain ports at your option. Keep the remaining port plugged.
- ★3. Do not touch the screw because it is adjusted at the time of shipment.
- ★4. For detail of amplifier, refer to page A-87.
- ★5. If you use the special sequence valve, remove the plug.

● Foot Mounting Type

Mounting bracket is common to that of pressure compensator model.
Refer to page A-47 for the dimensions of mounting bracket.

- Detail of Amplifier
- Connecting Terminal

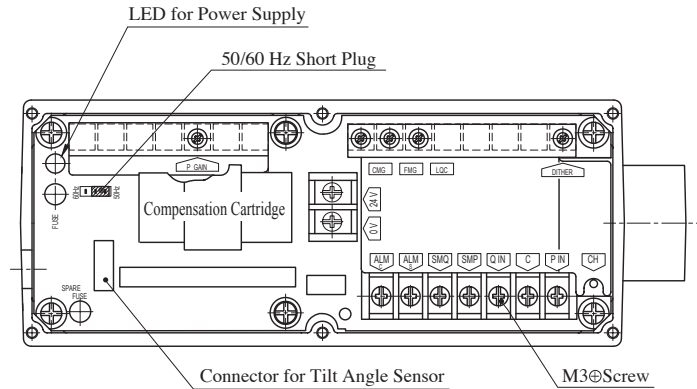

Terminal	Name
P IN	Input Signal, Pressure (+)
C	Input Signal (COM)
Q IN	Input Signal, Flow (+)
SMP	Sensor Monitor Output, Pressure
SMQ	Sensor Monitor Output, Tilt Angle
0 V	Power Supply
24 V	
ALM S	Alarm Output
ALM C	Alarm Output (COM)
CH	Output Current Check (to COM)

- Note 1. For "SENSOR MONITOR" terminal, external instruments should have input impedance of more than 10 kΩ.
2. For "CH" terminal, external instruments should have input impedance of more than 10 kΩ.
3. Volume adjustment of "DITHER", "GAIN", "CMG", "FMG" and "LQC" is made at the time of shipment. Adjustment at the customer is not required.
4. Use shielded cable for "Input" connection. The ground of the shielded cable must be connected to input signal side.

- Circuit Schematic

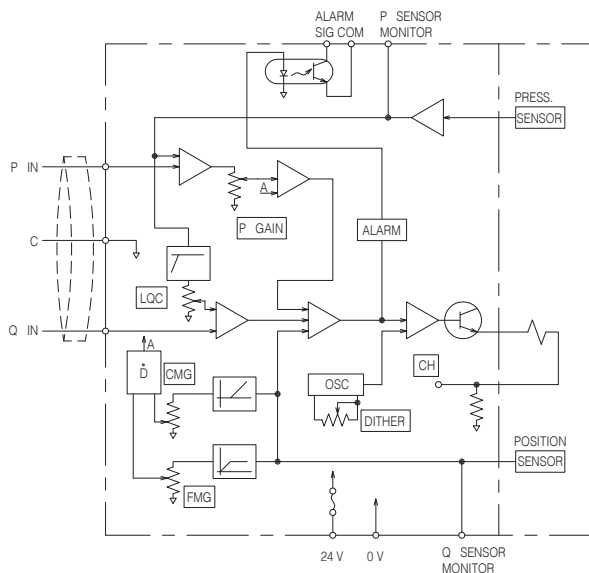

Series Variable Displacement Piston Pumps, Two-Pressure Two-Flow Control Type By System Pressure

Graphic Symbol

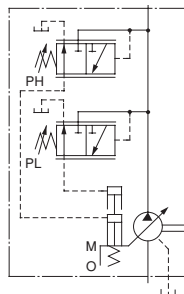

■ Performance Characteristics

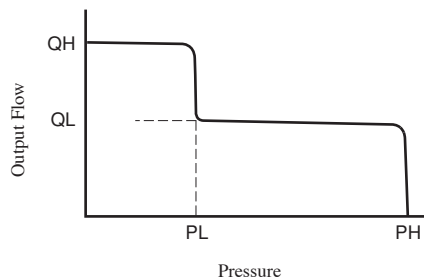

■ Specifications

Model Numbers	Geometric Displacement cm ³ /rev	Delivery Volume Adj. Range cm ³ /rev		Operating Pressure MPa		Shaft Speed Range r/min	
		Large Displacement (QH)	Small Displacement (QL)	Rated	Intermittent	Max.	Min.
A16- *-R-05- *- *-S-K-32	15.8	2.6-15.8	2.6-11.1	16	21	1800	600
A37- *-R-05- *- *-S-K-32	36.9	4.1-36.9	4.1-20.1	16	21		
A56- *-R-05- *- *-S-K-32	56.2	3.4-56.2	3.4-25.1	16	21		

■ Model Number Designation

A16	-F	-R	-05	-B	C	-S	-K	-32
Series Number	Mounting	Direction of Rotation	Control Type	Pres. Adj. Range for High Pressure MPa	Pres. Adj. Range for Low Pressure MPa	Port Position	Shaft Extension	Design Number
A16 (15.8 cm ³ /rev)	F: Flange Mtg.	(Viewed from Shaft End)	05: Two Pressure Two Flow Control Type by System Pressure	B: 2.5 - 7 C: 2.5 - 16 H: 2.5 - 21	B: 2.5 - 7 C: 2.5 - 16 H: 2.5 - 21	None: Axial Port S: Side Port	K: Keyed Shaft	32
A37 (36.9 cm ³ /rev)								L: Foot Mtg.
A56 (56.2 cm ³ /rev)								32

Consult Yuken when detailed material such as dimensions figures is required.

Series Variable Displacement Piston Pumps, Two-Pressure Two-Flow Control Type By Solenoid Valve

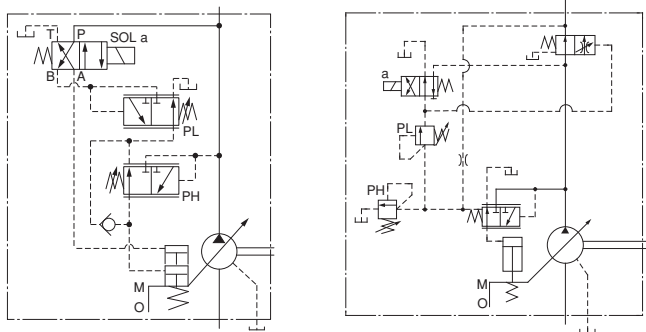
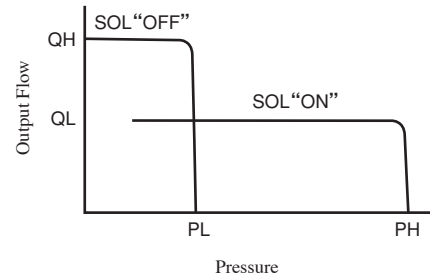
Graphic Symbols

A16/A22/A37/A56
A70/A90/A145
Performance Characteristics

Specifications

Model Numbers	Geometric Displacement cm ³ /rev	Delivery Volume Adj. Range cm ³ /rev		Operating Pressure MPa		Shaft Speed Range r/min	
		Large Displacement (QH)	Small Displacement (QL)	Rated	Intermittent	Max.	Min.
A16- *R-06- * *-S-K- *-33	15.8	2.6 - 15.8	2.6 - 11.1	16	21	1800	600
A22- *R-06- * *-S-K- *-33	22.2	3.7 - 22.2	3.7 - 15.5	16	16		
A37- *R-06- * *-S-K- *-33	36.9	4.1 - 36.9	4.1 - 20.1	16	21		
A56- *R-06- * *-S-K- *-33	56.2	3.4 - 56.2	3.4 - 25.1	16	21		
A70- *R06S * -70	70.0	36 - 70.0	3 - 70.0	25	25		
A90- *R06S * -70	91.0	56 - 91.0	3 - 70.0	25	25		
A145- *R06S * -60	145	83 - 145	3 - 145	25	25		

Model Number Designation

A16	-F	-R	-06	-B	C	-S	-K	A200	-33
Series Number	Mounting	Direction of Rotation	Control Type	Pres. Adj. Range for High Pressure MPa	Pres. Adj. Range for Low Pressure MPa	Port Position	Shaft Extension	Coil Type of Solenoid Valve	Design Number
A16 (15.8 cm ³ /rev)	F: Flange Mtg. L: Foot Mtg.	(Viewed from Shaft End) R: Clockwise (Normal)	06: Two-Pressure Two-Flow Control Type by Solenoid Valve	B: 2.5 - 7 C: 2.5 - 16 H: 2.5 - 21	B: 2.5 - 7 C: 2.5 - 16 H: 2.5 - 21	S: Side Port	K: Keyed Shaft	AC A100, A120 A200, A240 DC D12, D24 D48 R(AC→DC Rectified) R100, R200	33
A22 (22.2 cm ³ /rev)									33
A37 (36.9 cm ³ /rev)									33
A56 (56.2 cm ³ /rev)									33

A70	-F	R	06	S	A200	-70
Series Number	Mounting	Direction of Rotation	Control Type	Port Position	Coil Type of Solenoid Valve	Design Number
A70 (70.0 cm ³ /rev)	F: Flange Mtg. L: Foot Mtg.	(Viewed from Shaft End) R: Clockwise (Normal)	06: Two-Pressure Two-Flow Control Type by Solenoid Valve	S: Side Port	AC A100, A120 A200, A240 DC D12, D24 D48 R(AC→DC Rectified) R100, R200	70
A90 (91.0 cm ³ /rev)						70
A145 (145 cm ³ /rev)						60

Consult Yuken when detailed material such as dimensions figures is required.

Series Variable Displacement Piston Pumps, Pilot Pressure Control Type Pressure Compensator

Graphic Symbol

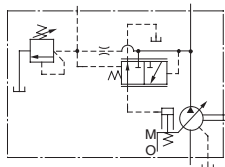

Performance Characteristics

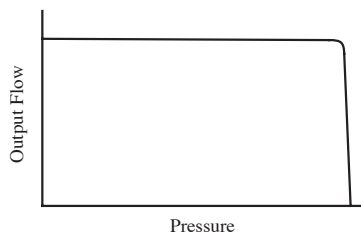

Specifications

Model Numbers	Geometric Displacement cm ³ /rev	Minimum Adj. Flow cm ³ /rev	Operating Pressure MPa		Minimum Adj. Pres. MPa	Shaft Speed Range r/min		Approx. Mass kg	
			Rated ^{*2}	Intermittent ^{*1}		Max.	Min.	Flange Mtg.	Foot Mtg.
A10-FR07-13	10.0	2	16	21	2.0	1800	600	9.5	—
A16- [*] R-07- [*] K-32	15.8	4	16	21	1.2	1800	600	21	23.2
A22- [*] R-07- [*] K-32	22.2	6	16	16	1.2	1800	600	21	23.2
A37- [*] R-07- [*] K-32	36.9	10	16	21	1.2	1800	600	29	33.3
A56- [*] R-07- [*] K-32	56.2	12	16	21	1.2	1800	600	36	40.3
A70- [*] R07S-70	70.0	36	25	25	2	1800	600	60.3	72.3
A90- [*] R07S-70	91.0	56	25	25	2	1800	600	77.5	98
A145- [*] R07S-60	145	83	25	25	2	1800	600	94	119

★1. Whenever setting pressure, make sure the full cut-off pressure never exceeds the maximum intermittent pressure.

★2. When operating the pump exceeding the rated pressure, operating conditions are restricted.

Refer to page A-28 for details.

Model Number Designation

A16	-F	-R	-07	-S	-K	-32
Series Number	Mounting	Direction of Rotation	Control Type	Port Position	Shaft Extension	Design Number
A16 (15.8 cm ³ /rev)	F: Flange Mtg. L: Foot Mtg.	(Viewed from) Shaft End R: Clockwise ^{*1} (Normal)	07: Pilot Pressure Control Type Pressure Compensator	None: Axial Port S: Side Port	K: Keyed Shaft	32
A22 (22.2 cm ³ /rev)						32
A37 (36.9 cm ³ /rev)						32
A56 (56.2 cm ³ /rev)						32

A70	-F	R	07	S	-70
Series Number	Mounting	Direction of Rotation	Control Type	Port Position	Design Number
A10 (10.0 cm ³ /rev)	F: Flange Mtg. ^{★2}	(Viewed from) Shaft End R: Clockwise ^{*1} (Normal)	07: Pilot Pressure Control Type Pressure Compensator	—	13
A70 (70.0 cm ³ /rev)	F: Flange Mtg.			S: Side Port	70
A90 (91.0 cm ³ /rev)	L: Foot Mtg.			70	
A145 (145 cm ³ /rev)	L: Foot Mtg.			60	

★1. Available to supply pump with anti-clockwise rotation. Consult Yuken for details.

★2. When A10 pump is used as the foot Mtg., order the Mtg. bracket kit shown below separately.

Refer to page A-17 for dimensions of the Mtg. bracket.

Mtg. Bracket Kit Numbers	Approx. Mass kg
LP-1A-10	2.2

Note: The mounting bracket kit consists of a mounting bracket, 2 hex. bolts and 2 plain washers.

Performance Characteristics

For performance characteristics, refer to models of pressure compensator type on page A-31 to A-34, A-36 to A-38 and A-40.

Pipe Flange Kit

For pipe flange, refer to form of pressure compensator type on page A-29.

Flange Mtg. : A10-FR07

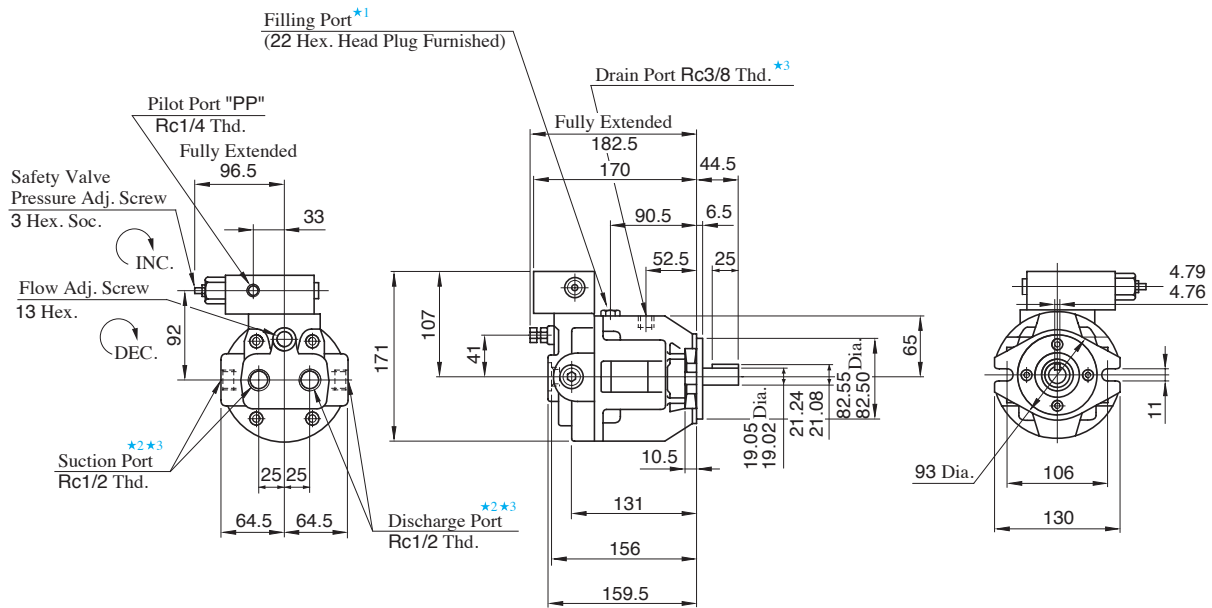

- ★1. Install the pump so that the "Filling Port" is at the top.
- ★2. Use either port of two suction and discharge ports at your option. Keep the remaining ports plugged.
- ★3. As the tightening torques of suction, discharge and drain port fittings, conform to the below.

Model Numbers	Tightening Torque Nm	
	Suction Port & Discharge Port	Drain Port
A10-FR07-12	65 - 75	40 - 50

Axial Port Type

**Flange Mtg. : A16-F-R-07-K
A22-F-R-07-K**

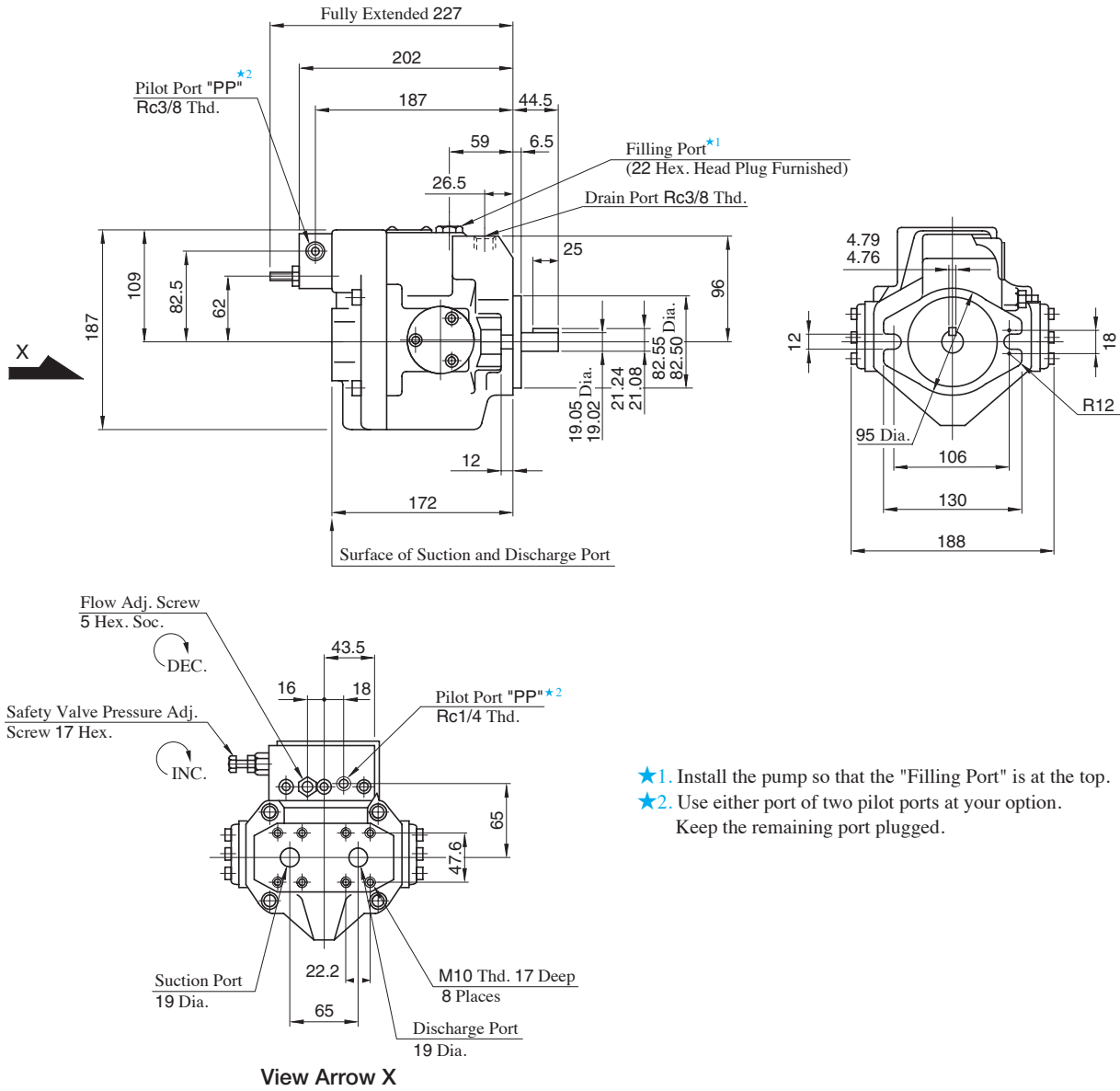

- ★1. Install the pump so that the "Filling Port" is at the top.
- ★2. Use either port of two pilot ports at your option. Keep the remaining port plugged.

● **Axial Port Type**

Port mounting dimensions are the same as those of pressure compensator model. Refer to page A-42 for port mounting dimensions.

● **Foot Mounting Type**

Mounting bracket is common to that of pressure compensator model. Refer to page A-42 for the dimensions of mounting bracket.

Side Port Type

Flange Mtg. : A37-F-R-07-S-K

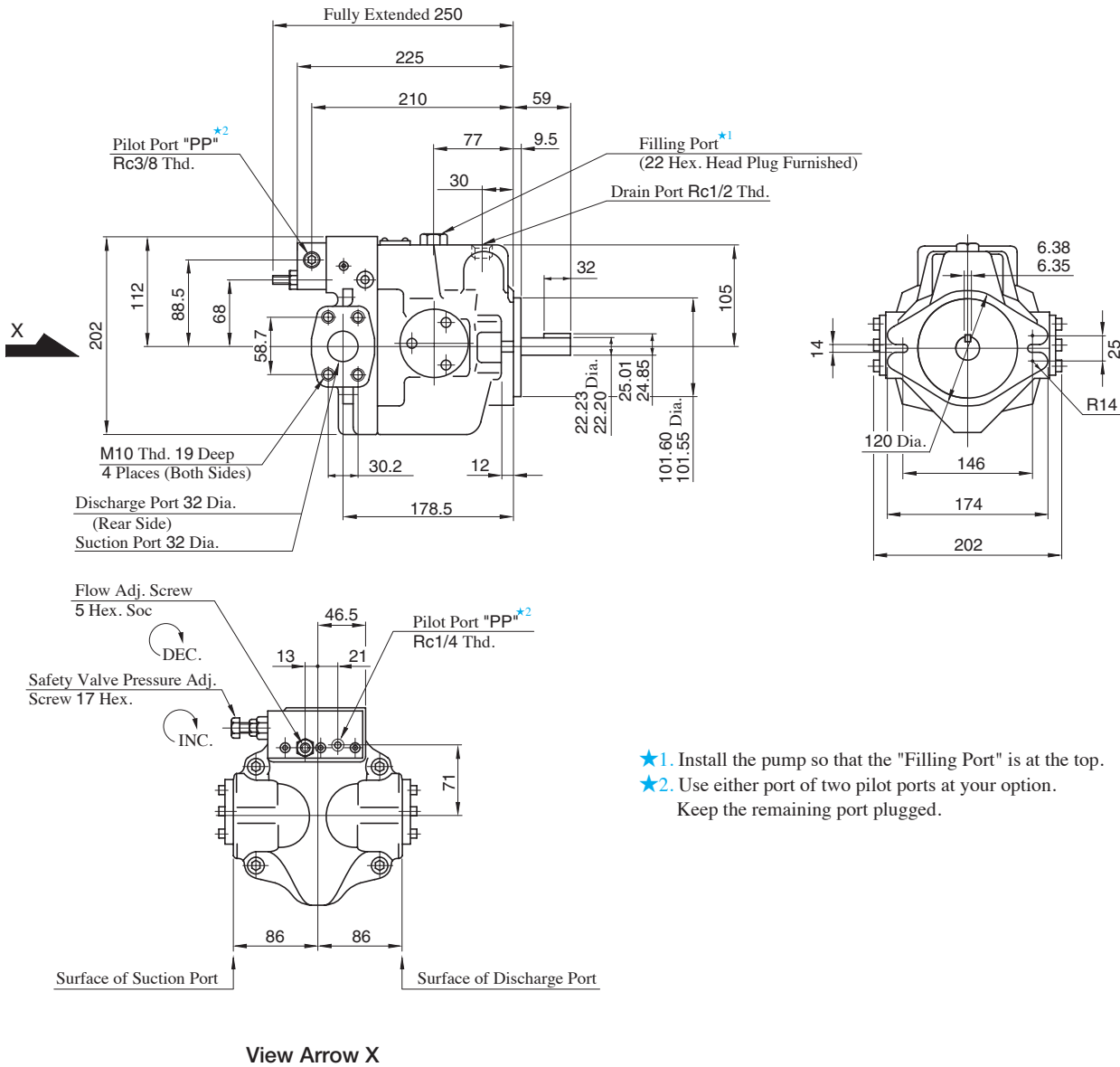

- ★1. Install the pump so that the "Filling Port" is at the top.
- ★2. Use either port of two pilot ports at your option. Keep the remaining port plugged.

● Axial Port Type

Port mounting dimensions are the same as those of pressure compensator model. Refer to page A-43 for port mounting dimensions.

● Foot Mounting Type

Mounting bracket is common to that of pressure compensator model. Refer to page A-43 for the dimensions of mounting bracket.

Side Port Type

Flange Mtg. : A56-F-R-07-S-K

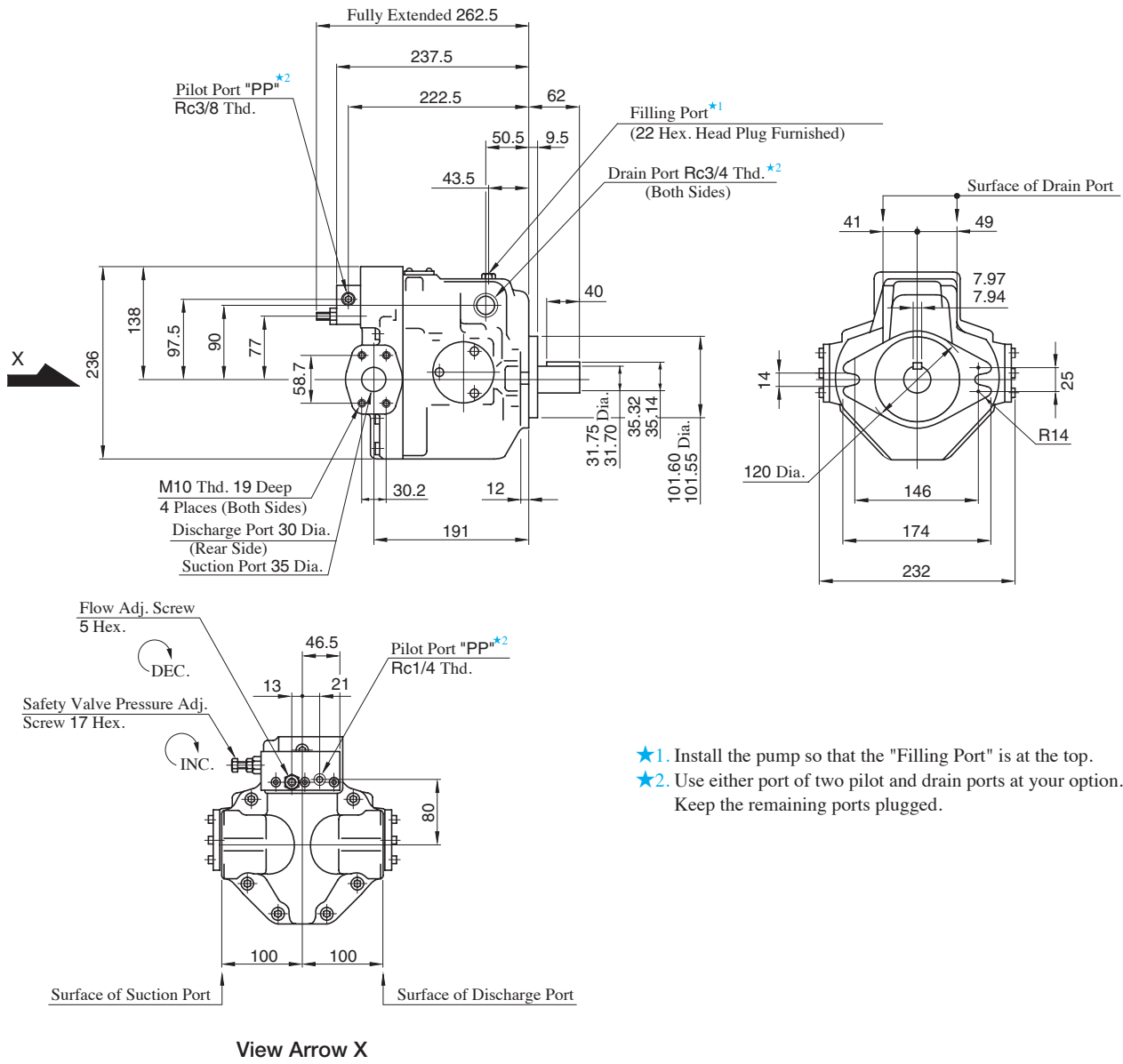

- ★1. Install the pump so that the "Filling Port" is at the top.
- ★2. Use either port of two pilot and drain ports at your option. Keep the remaining ports plugged.

● **Axial Port Type**

Port mounting dimensions are the same as those of pressure compensator model. Refer to page A-44 for port mounting dimensions.

● **Foot Mounting Type**

Mounting bracket is common to that of pressure compensator model. Refer to page A-44 for the dimensions of mounting bracket.

Flange Mtg. : A70-FR07S

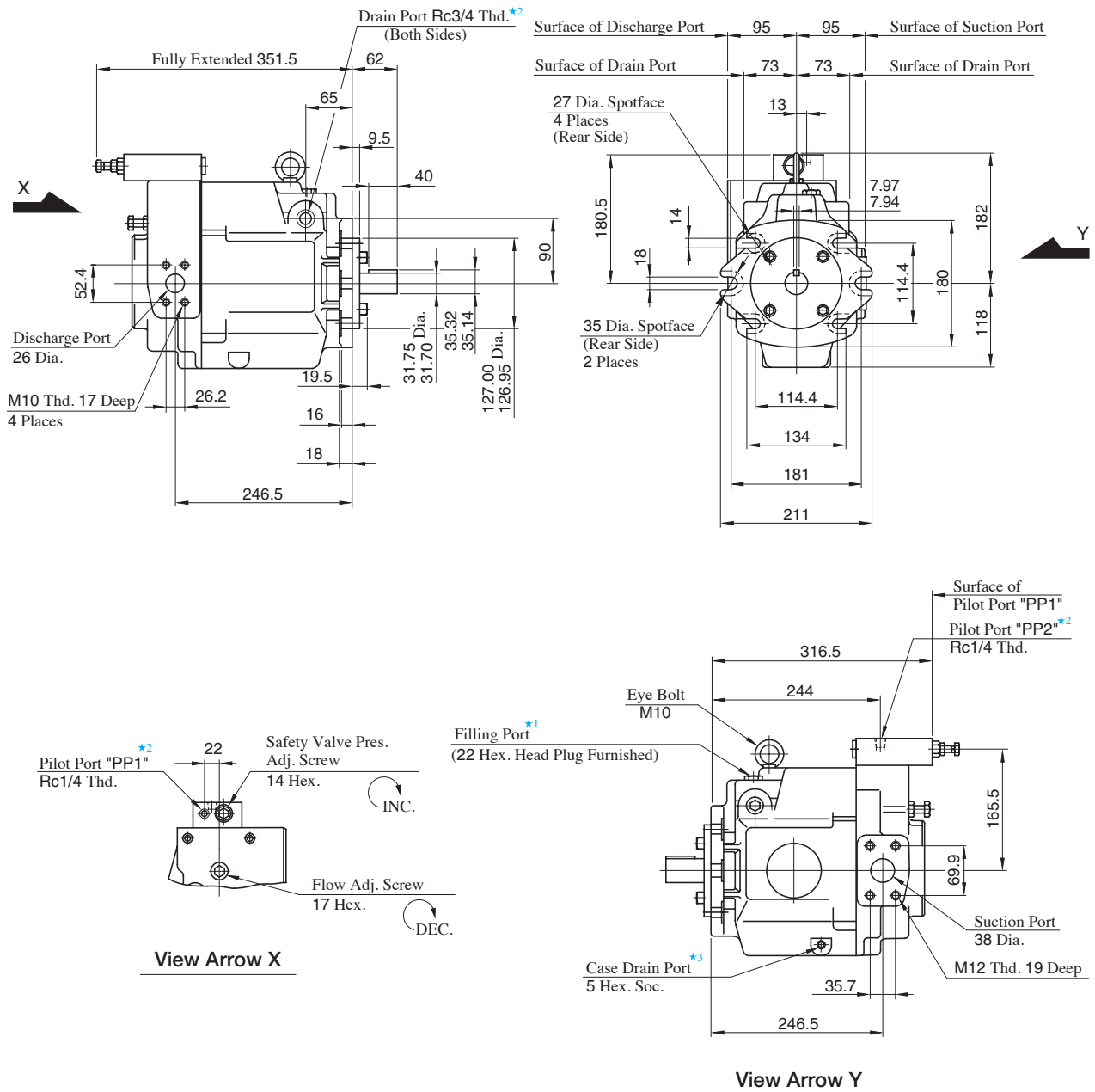

- ★1. Install the pump so that the "Filling Port" is at the top.
- ★2. Use either port of two pilot and drain ports at your option. Keep the remaining ports plugged.
- ★3. Case drain port is available for use when draining hydraulic fluid from pump casing.

● Foot Mounting Type

Mounting bracket is common to that of pressure compensator model.
Refer to page A-45 for the dimensions of mounting bracket.

Flange Mtg. : A90-FR07S

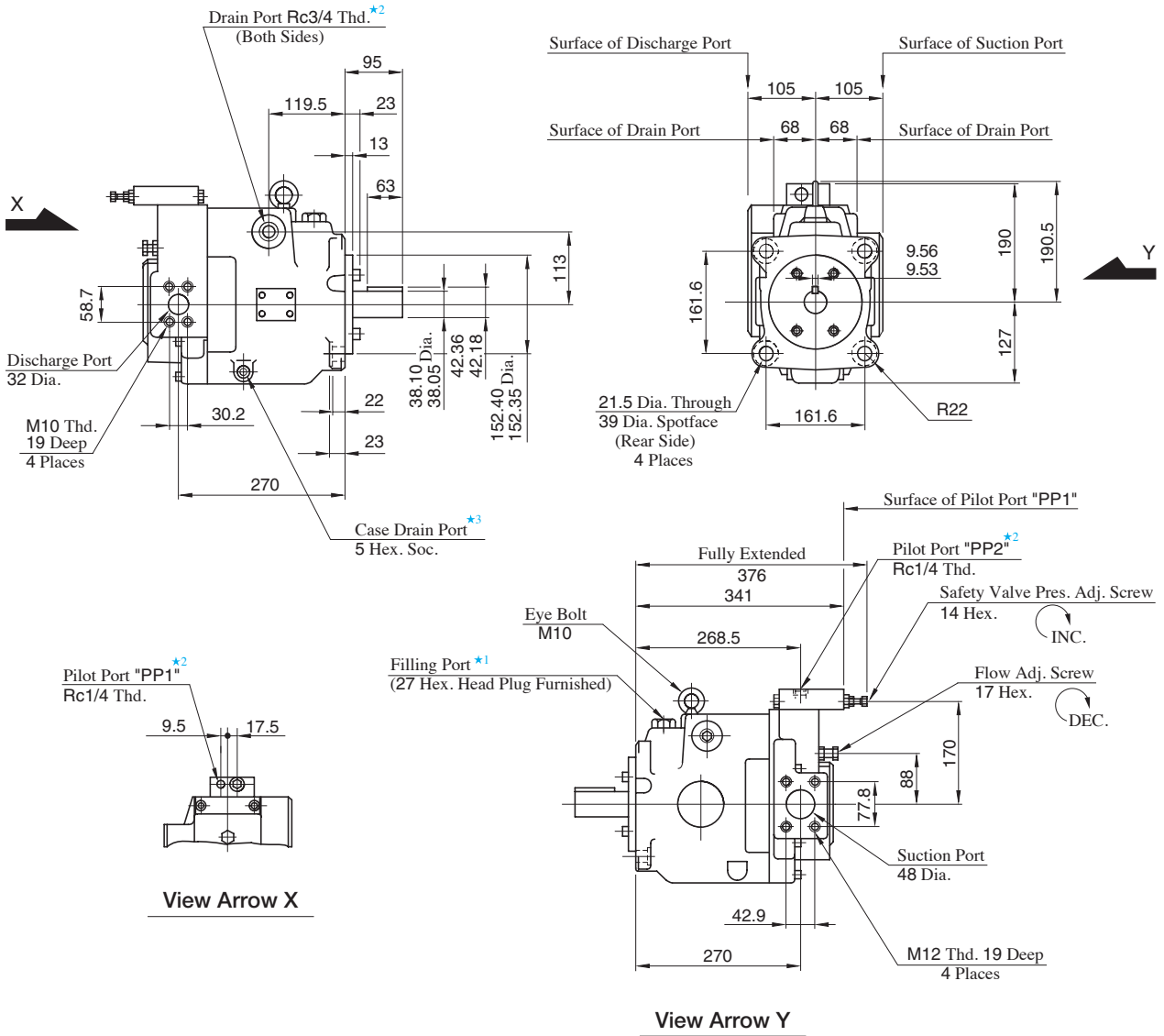

- ★1. Install the pump so that the "Filling Port" is at the top.
- ★2. Use either port of two pilot and drain ports at your option. Keep the remaining ports plugged.
- ★3. Case drain port is available for use when draining hydraulic fluid from pump casing.

● **Foot Mounting Type**

Mounting bracket is common to that of pressure compensator model.
Refer to page A-46 for the dimensions of mounting bracket.

Flange Mtg. : A145-FR07S

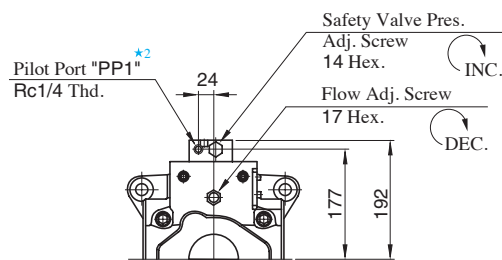
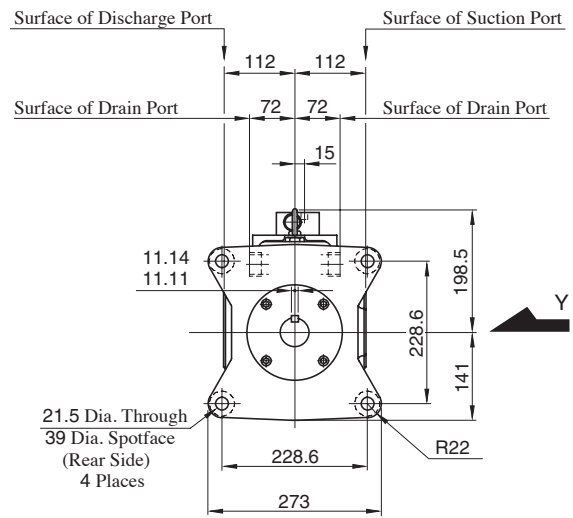
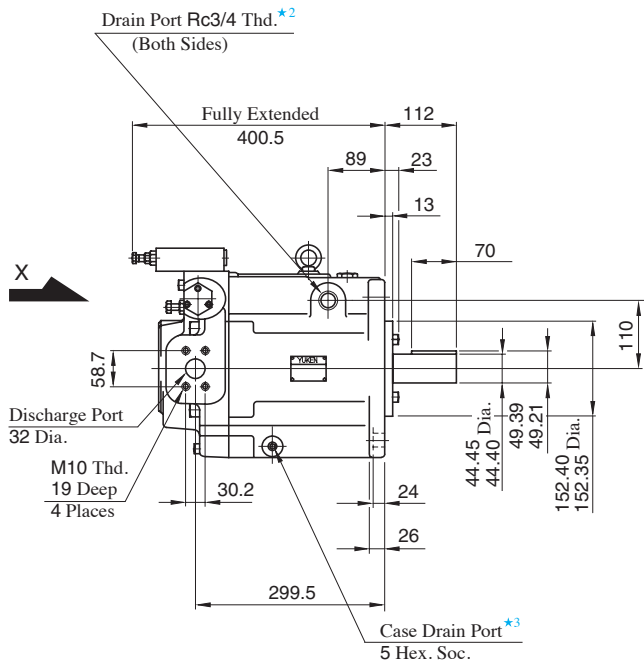

View Arrow X

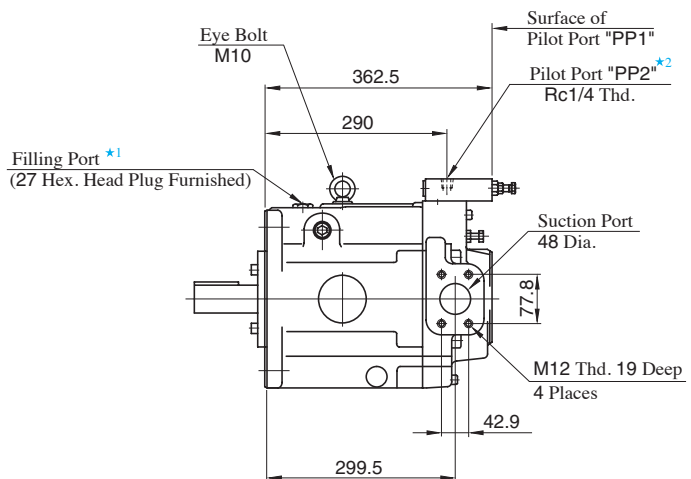

View Arrow Y

- ★1. Install the pump so that the "Filling Port" is at the top.
- ★2. Use either port of two pilot and drain ports at your option. Keep the remaining ports plugged.
- ★3. Case drain port is available for use when draining hydraulic fluid from pump casing.

● Foot Mounting Type

Mounting bracket is common to that of pressure compensator model.
Refer to page A-47 for the dimensions of mounting bracket.

A Series Variable Displacement Piston Pumps, Constant Power Control Type

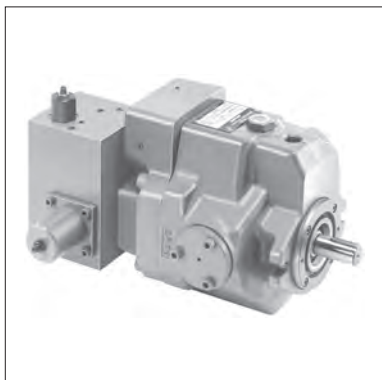

■ Performance Characteristics

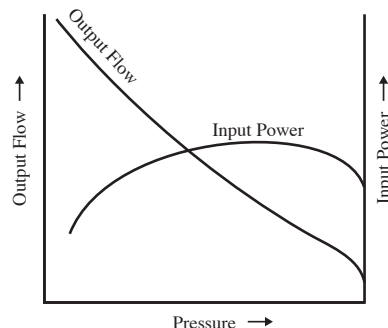

Graphic Symbols

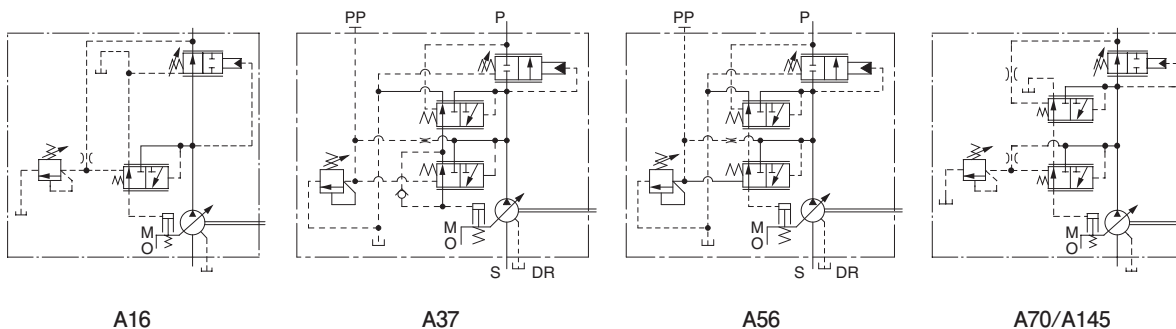

■ Specifications

Model Numbers	Geometric Displacement cm ³ /rev	Minimum ^{★2} Adj. Flow cm ³ /rev	Operating Pres. MPa	Shaft Speed Range r/min		Approx. Mass kg	
			Max.	Max.	Min.	Flange Mtg.	Foot Mtg.
A16- *-R-09- *- *-K-32	15.8	—	21 ^{★1}	1800	600	29.0	31.2
A37- *-R-09- *- *-K-32	36.9	—	21 ^{★1}	1800	600	37.0	41.3
A56- *-R-09- *- *-K-32	56.2	—	21 ^{★1}	1800	44.0	44.0	48.3
A70- *R09* S-70	70.0	36	25	1800	600	72.8	84.8
A145- *R09* S-60	145	83	25	1800	600	110	135

★1. Maximum operating pressure of A16/A37/A56 varies according to input power setting. See “Model Number Designation” for details.

★2. Minimum adjustment flow of A70/A145 is absolutely minimum flow that can be adjusted with flow adjustment screw.

Model Number Designation

A16/A37/A56

A16	-F	-R	-09	-A		-16M	-K	-32
Series Number	Mounting	Direction of Rotation	Control Type	Input Power Setting		Specify Control Pres.	Shaft Extension	Design Number
A16 (15.8 cm ³ /rev)	F: Flange Mtg.	(Viewed from Shaft End)	09: Constant Power Control Type	A : 3.7 kW	E : 2.2 kW	7M : 7 Pa 10.5M : 10.5 Pa 14M : 14 Pa 16M : 16 Pa 17.5M : 17.5 Pa 21M : 21 Pa	K: Keyed Shaft	32
B : 5.5 kW				F : 1.5 kW				
A37 (36.9 cm ³ /rev)	L: Foot Mtg.	R: Clockwise* ¹ (Normal)		A : 3.7 kW	C : 7.5 kW			
A56 (56.2 cm ³ /rev)			B : 5.5 kW	D : 11 kW				
				A : 3.7 kW	E : 15 kW			
				B : 5.5 kW	F : 18.5 kW			
				C : 7.5 kW	G : 22 kW			
				D : 11 kW				

A70/A145

A70	-F	R	09	-A		S	-70
Series Number	Mounting	Direction of Rotation	Control Type	Input Power Setting		Direction of Port	Design Number
A70 (70 cm ³ /rev)	F: Flange Mtg.	(Viewed from Shaft End)	09: Constant Power Control Type	A : 15 kW	C : 22 kW	S: Side Port	70
A145 (145 cm ³ /rev)	L: Foot Mtg.	R: Clockwise* ¹ (Normal)		B : 18.5 kW	D : 30 kW		
			A : 15 kW	E : 37 kW	60		
B : 18.5 kW	F : 45 kW						
C : 22 kW	G : 55 kW						
D : 30 kW	H : 75 kW						

*1. Available to supply pump with anti-clockwise rotation. Consult Yuken for details.

*2. Specify control pressure of A16/A37/A56 with lower than maximum operating pressure depending on input power setting.

Model	Maximum Operating Pressure MPa								
	1.5 kW	2.2 kW	3.7 kW	5.5 kW	7.5 kW	11 kW	15 kW	18.5 kW	22 kW
A16	10.5	16	21	21	—	—	—	—	—
A37	—	—	16	21	21	21	—	—	—
A56	—	—	10.5	14	17.5	21	21	21	21

Pipe Flange Kits

Pipe flange kits are available. When ordering, specify the kit number from the table below.

Pump Model Numbers	Name of Port	Pipe Flange Kit Numbers		
		Threaded Connection	Socket Welding* ¹	Butt Welding
A16- *-R-09	Suction	F5-06-A-10	F5-06-B-10	F5-06-C-10
	Discharge	—* ²	—* ²	—* ²
A37- *-R-09	Suction	F5-10-A-10	F5-10-B-10	F5-10-C-10
A56- *-R-09	Discharge	F5-06-A-10	F5-06-B-10	F5-06-C-10
A70- *-R-09	Suction	F5-12-A-10	F5-12-B-10	F5-12-C-10
	Discharge	F5-08-A-10	F5-08-B-10	F5-08-C-10
A145- *-R-09	Suction	F5-16-A-10	F5-16-B-10	F5-16-C-10
	Discharge	F5-10-A-10	F5-10-B-10	F5-10-C-10

*1. In case of using socket welding flanges, there is a case where the operating pressure should be set lower than the normal because of strength of flanges. Therefore, please pay cautious attention to the operating pressure when the socket welding flanges are used.

*2. Discharge port for pump model "A16" is available only the threaded connections.

● Detail of the pipe flange kits are shown on pages A-258 and A-259.

Typical Performance Characteristics at 1500 r/min

● A16

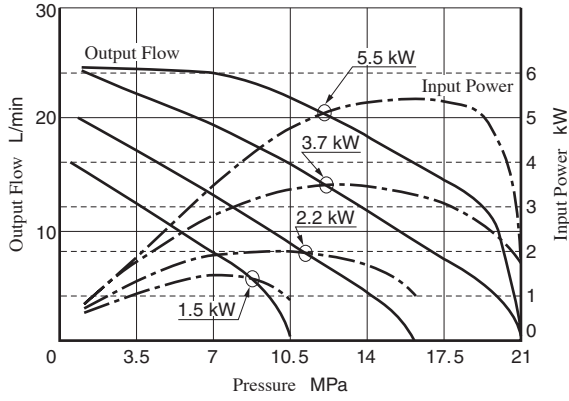

● A70

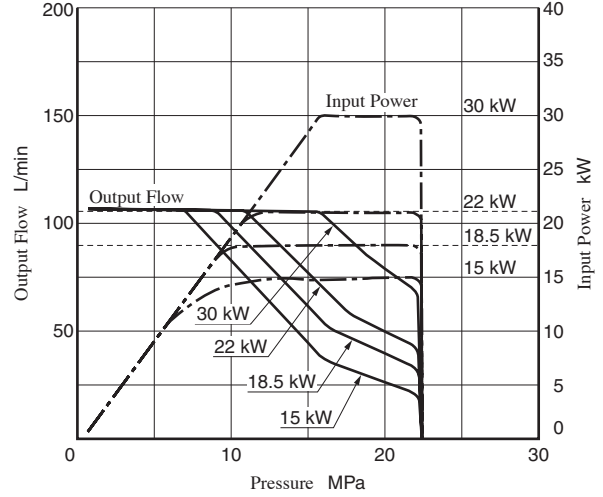

● A37

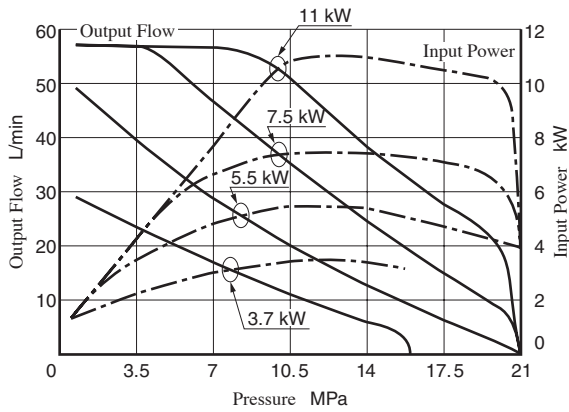

● A145

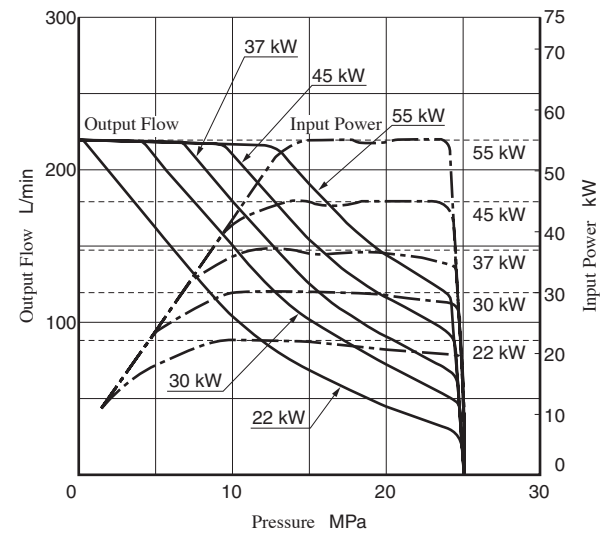

● A56

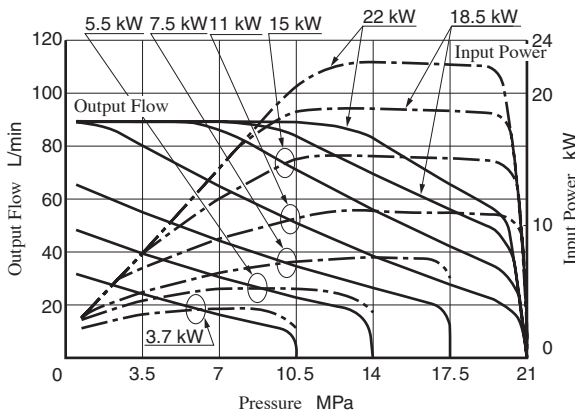

Flange Mtg. : A16-F-R-09- *-K

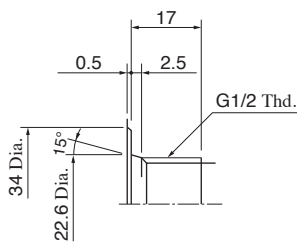
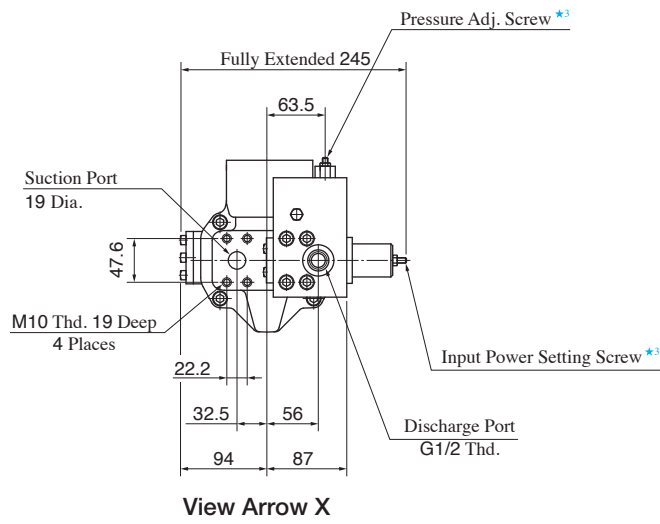
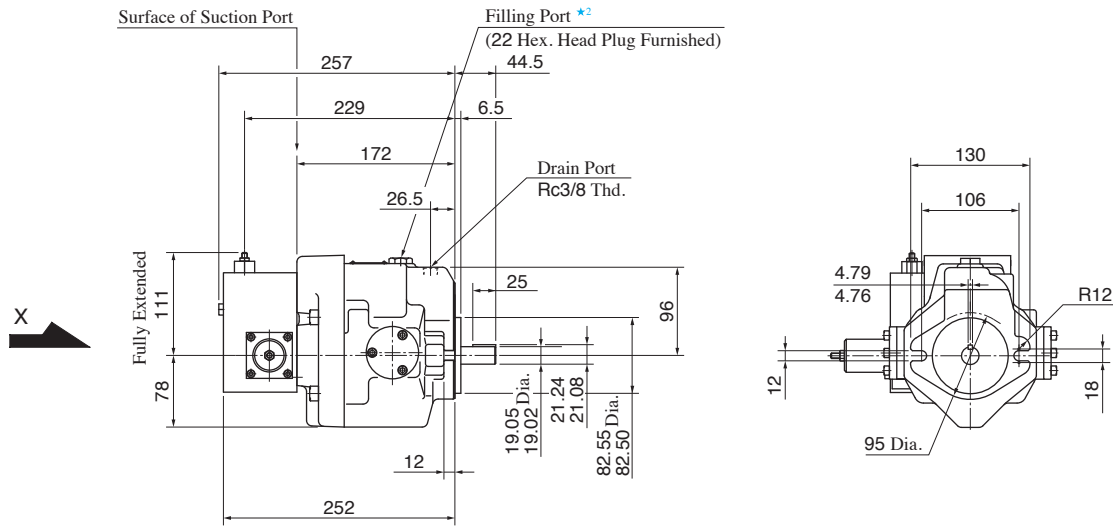

- ★1. Detail of Discharge Port
- ★2. Install the pump so that the "Filling Port" is at the top.
- ★3. Do not touch the screw because it is adjusted at the time of shipment.

● Foot Mounting Type

Mounting bracket is common to that of pressure compensator model.
Refer to page A-42 for the dimensions of mounting bracket.

Flange Mtg. : A37-F-R-09- *-K

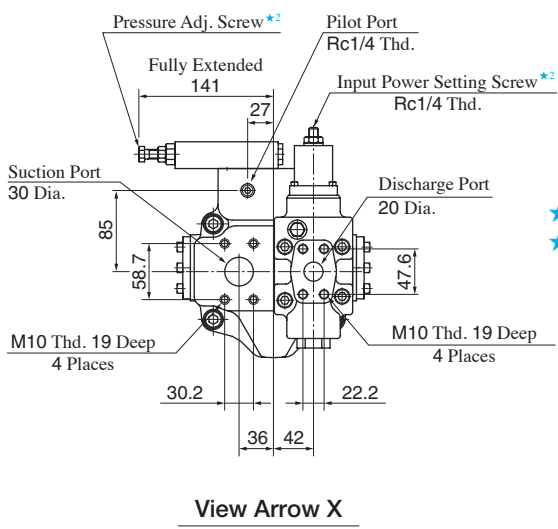
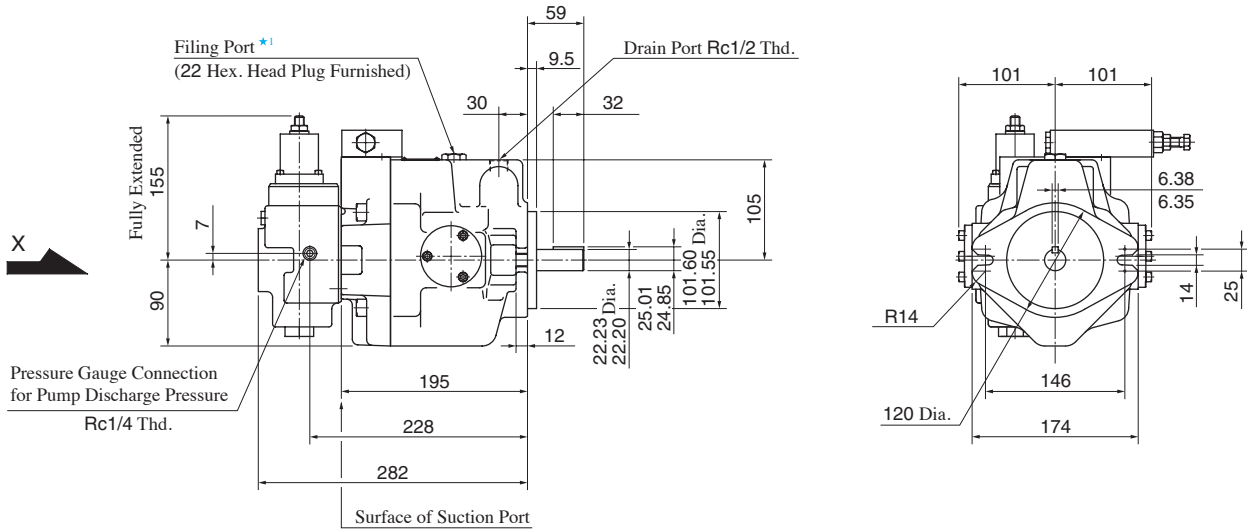

- ★1. Install the pump so that the "Filling Port" is at the top.
- ★2. Do not touch the screw because it is adjusted at the time of shipment.

Foot Mtg. : A37-L-R-09- *-K

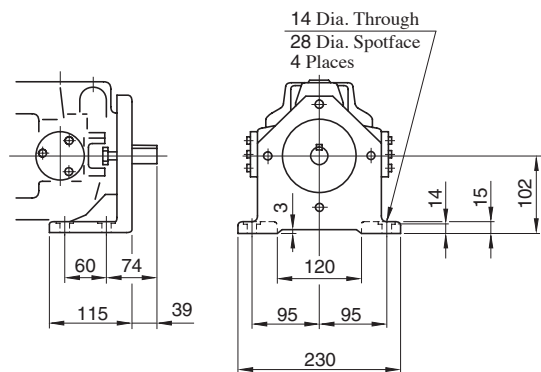

● For other dimensions, refer to "Flange Mtg.".

Flange Mtg. : A56-F-R-09- * -K

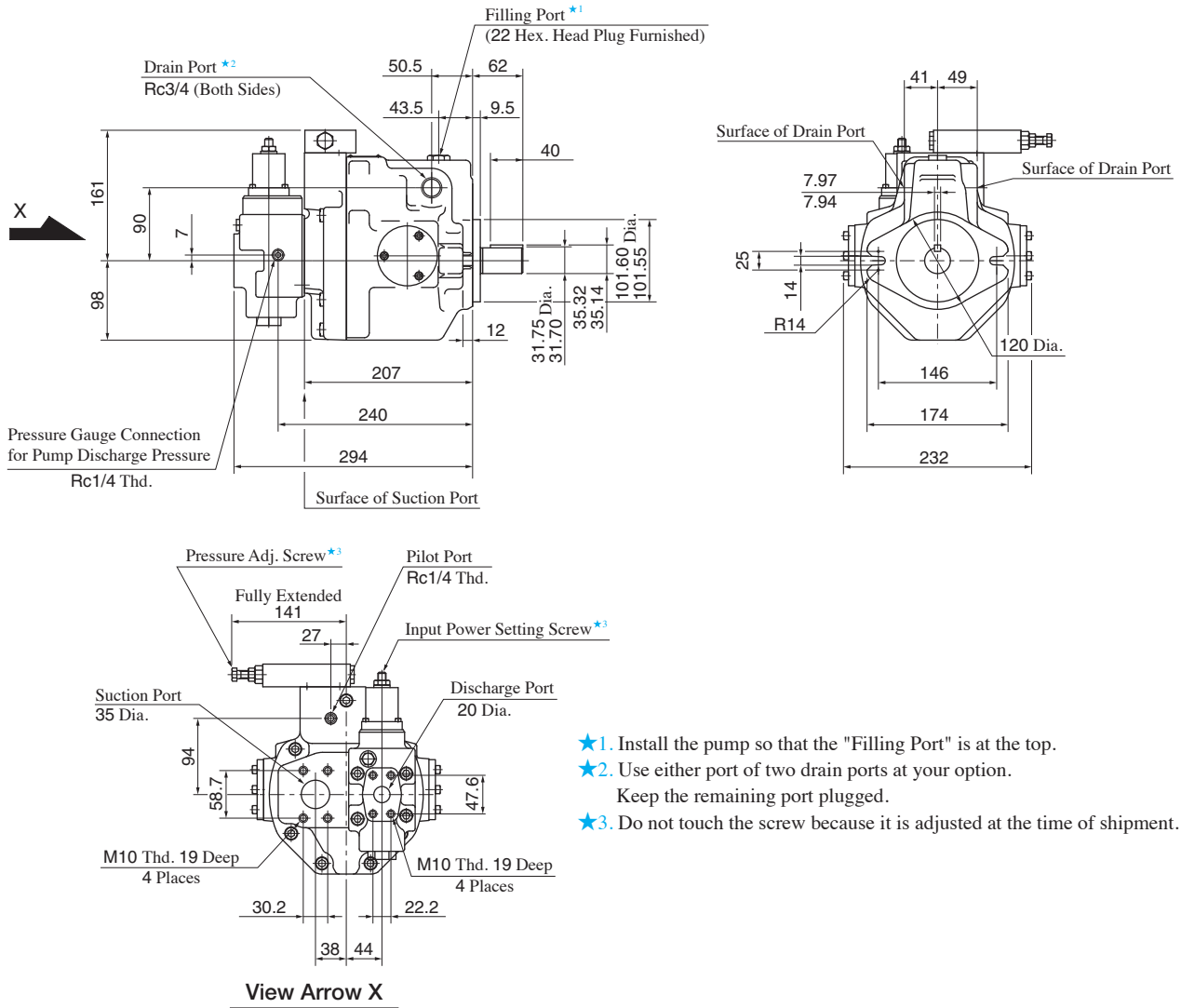

Foot Mtg. : A56-L-R-09- * -K-32

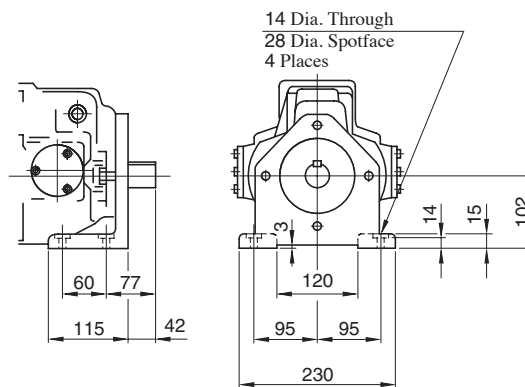

● For other dimensions, refer to "Flange Mtg.".

Flange Mtg. : A70-FR09 * S

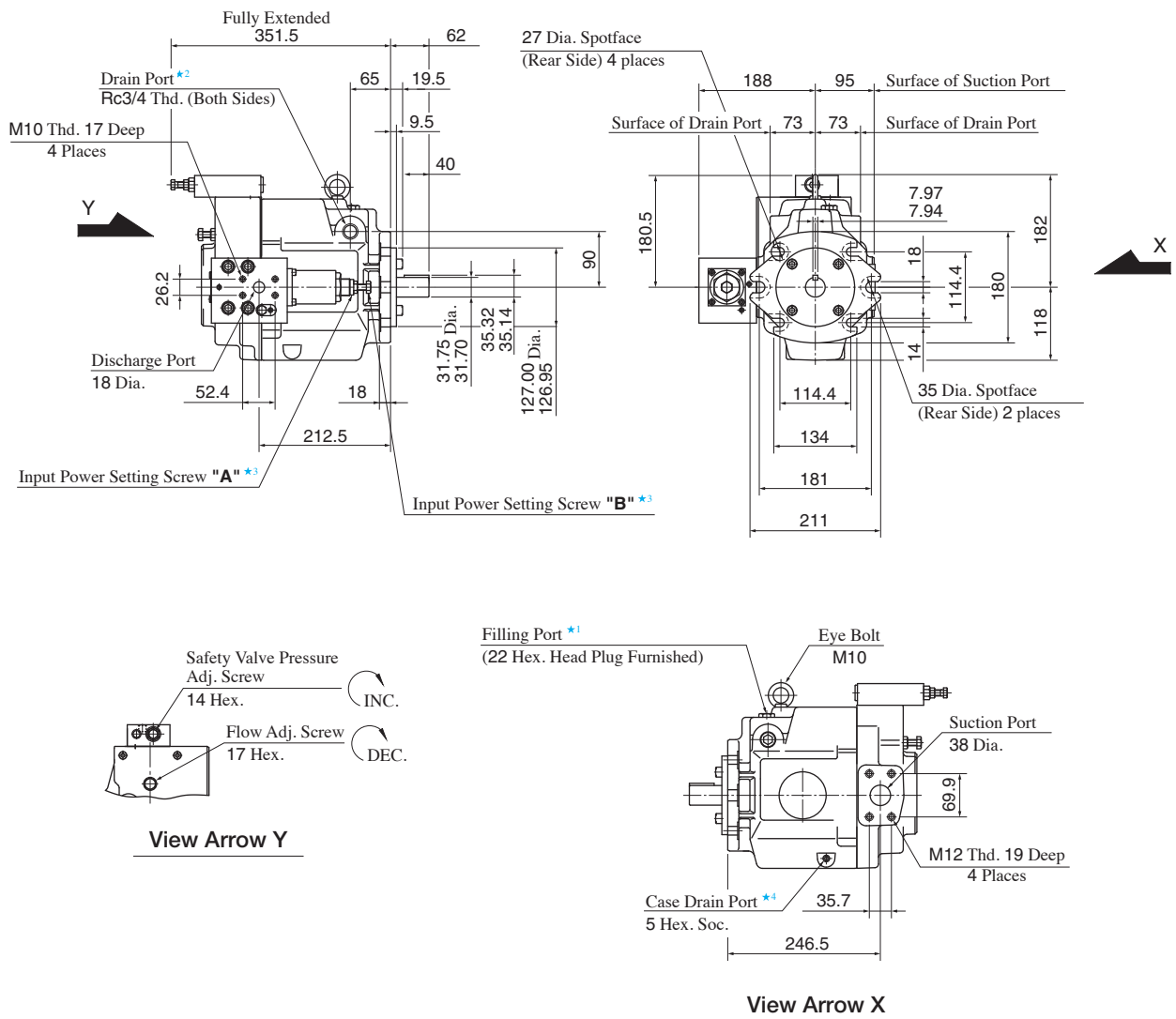

- ★1. Install the pump so that the "Filling Port" is at the top.
- ★2. Use either port of two drain ports at your option. Keep the remaining port plugged.
- ★3. Do not touch the screw because it is adjusted at the time of shipment.
- ★4. Case drain port is available for use when draining hydraulic fluid from pump casing.

● **Foot Mounting Type**

Mounting bracket is common to that of pressure compensator model.
Refer to page A-45 for the dimensions of mounting bracket.

Flange Mtg. : A145-FR09 * S

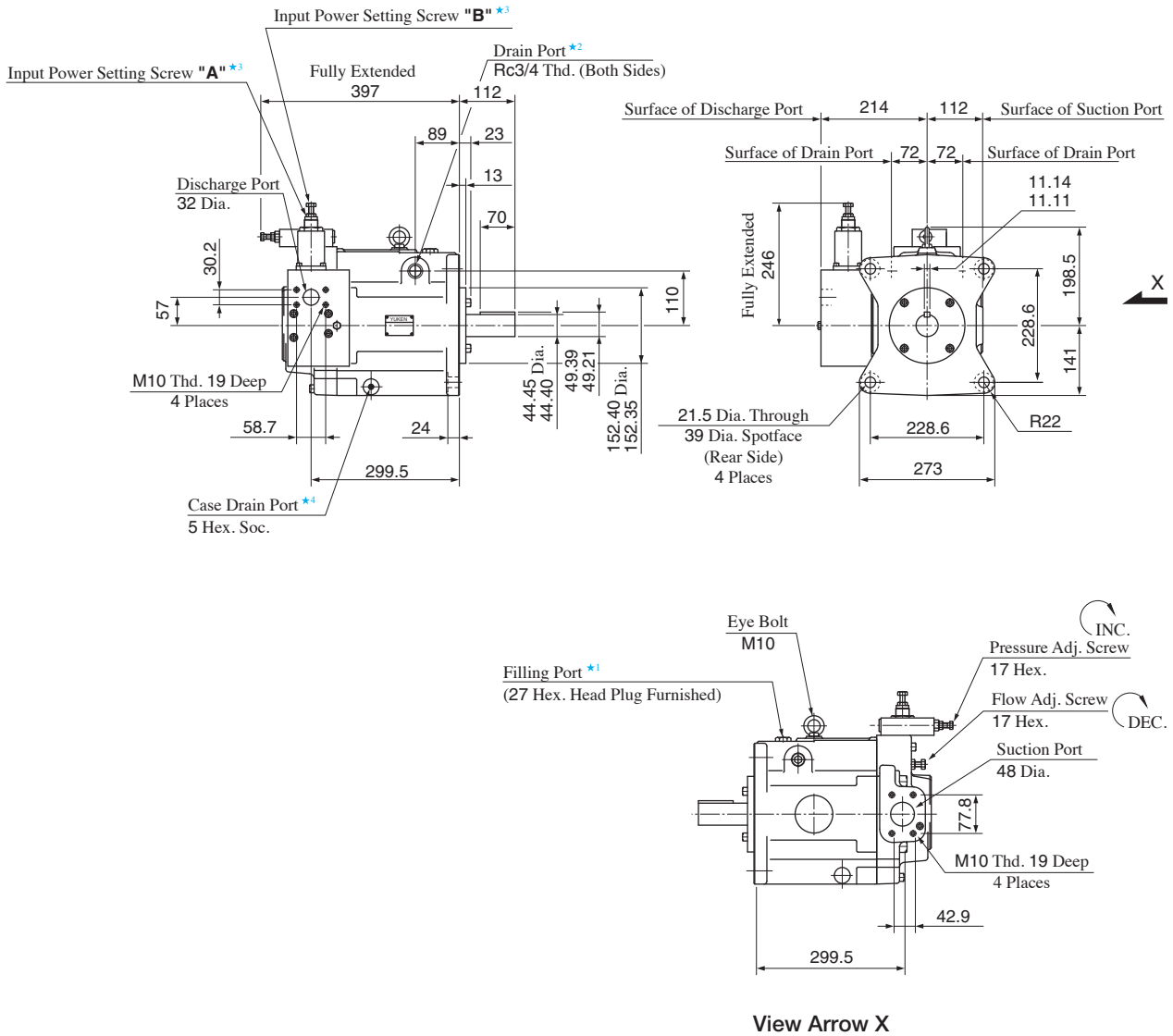

- ★1. Install the pump so that the "Filling Port" is at the top.
- ★2. Use either port of two drain ports at your option. Keep the remaining port plugged.
- ★3. Do not touch the screw because it is adjusted at the time of shipment.
- ★4. Case drain port is available for use when draining hydraulic fluid from pump casing.

● Foot Mounting Type

Mounting bracket is common to that of pressure compensator model.
Refer to page A-47 for the dimensions of mounting bracket.

Series Variable Displacement Piston Pumps - Single Pump, Simple Two-Pressure Two-Flow Control Type

Specifications

Model Numbers	Geometric Displacement cm ³ /rev	Output Flow Adj. Range cm ³ /rev		Operating Pressure MPa		Shaft Speed Range r/min
		Large Displacement (QH)	Small Displacement (QL)	Rated	Intermittent	
A16- *-R-00-H-K-32500	15.8	4-15.8	3-10	16	21	600-1800
A37- *-R-00-H-K-32500	36.9	7-36.9	3-18	16	21	
A56- *-R-00-H-K-32500	56.2	9-56.2	3-25.0	16	21	
A70- *R00HS-70500	70.0	36-70.0	★-24	21	21	
A90- *R00HS-70500	91	56-91.0	★-45	21	21	
A145- *R00HS-60500	145	83-145	★-70	21	21	

Performance Characteristics

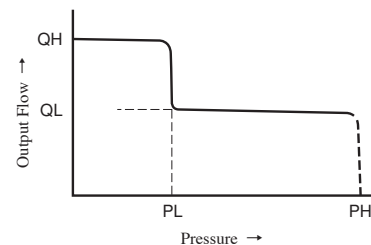

Graphic Symbol

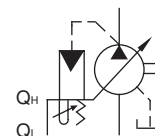

Note) ★: Minimum adjustment flow of relief valve, which is for setting with PH pressure. (Relief valve is external set.)

Instruction

As the pump does not have full cut-off function, setting relief valve of PH pressure (maximum pressure on circuit) for pump discharge line is absolutely required.

Model Number Designation

● A16-A56

A16	-F	-R	-00	-H	-K	-32500
Series Number	Mounting	Direction of Rotation	Control Type	Pres. Adj. Range MPa	Shaft Extension	Design Number
A16 (15.8 cm ³ /rev)	F : Flange Mtg. L : Foot Mtg.	(Viewed from Shaft End) R : Clockwise★ (Normal)	00 : Special Control Type	H : 1.2-21	K : Keyed Shaft	32500
A37 (36.9 cm ³ /rev)						32500
A56 (56.2 cm ³ /rev)						32500

● A70-A145

A70	-F	R	00	H	S	-70500
Series Number	Mounting	Direction of Rotation	Control Type	Pres. Adj. Range MPa	Port Position	Design Number
A70 (70.0 cm ³ /rev)	F : Flange Mtg. L : Foot Mtg.	(Viewed from Shaft End) R : Clockwise★ (Normal)	00 : Special Control Type	H : 2-21	S : Side Port	70500
A90 (91.0 cm ³ /rev)						70500
A145 (145 cm ³ /rev)						60500

★ Available to supply pump with anti-clockwise rotation. Consult Yuken for details.

Consult Yuken when detailed material such as dimensions figures is required.

A Series Variable Displacement Piston Pumps – Double Pumps, Pressure Compensator Type

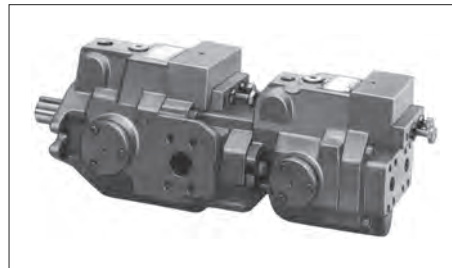

Graphic Symbol

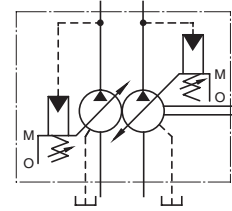

Specifications

Model Numbers		Geometric Displacement cm ³ /rev	Min. Adj. Flow cm ³ /rev	Operating Pressure MPa		Shaft Speed Range r/min		Approx. Mass kg	
				Rated	Intermittent	Max.	Min.	Flange Mtg.	Foot Mtg.
A1616- *R01 *01 * * K-32	Outboard Pump	15.8	4	16	21	1800	600	35.5	37.7
	Inboard Pump	15.8	4	16	21				
A1622- *R01 *01 * * K-32	Outboard Pump	15.8	4	16	21	1800	600	35.5	37.7
	Inboard Pump	22.2	6	16	16				
A2222- *R01 *01 * * K-32	Outboard Pump	22.2	6	16	16	1800	600	35.5	37.7
	Inboard Pump	22.2	6	16	16				
A1637- *R01 *01 * * K-32	Outboard Pump	15.8	4	16	21	1800	600	50	54.3
	Inboard Pump	36.9	10	16	21				
A2237- *R01 *01 * * K-32	Outboard Pump	22.2	6	16	16	1800	600	50	54.3
	Inboard Pump	36.9	10	16	21				
A1656- *R01 *01 * * K-32	Outboard Pump	15.8	4	16	21	1800	600	54.5	58.8
	Inboard Pump	56.2	12	16	21				
A2256- *R01 *01 * * K-32	Outboard Pump	22.2	6	16	16	1800	600	54.5	58.8
	Inboard Pump	56.2	12	16	21				
A1670- *R01 *01 * * -70	Outboard Pump	15.8	4	16	21	1800	600	77.5	89.5
	Inboard Pump	70.0	36	25	28				
A2270- *R01 *01 * * -70	Outboard Pump	22.2	6	16	16	1800	600	77.5	89.5
	Inboard Pump	70.0	36	25	28				
A3770- *R01 *01 * * -70	Outboard Pump	36.9	10	16	21	1800	600	86.5	98.5
	Inboard Pump	70.0	36	25	28				
A1690- *R01 *01 * * -70	Outboard Pump	15.8	4	16	21	1800	600	88	108.5
	Inboard Pump	91.0	56	25	28				
A2290- *R01 *01 * * -70	Outboard Pump	22.2	6	16	16	1800	600	88	108.5
	Inboard Pump	91.0	56	25	28				
A3790- *R01 *01 * * -70	Outboard Pump	36.9	10	16	21	1800	600	100.5	121
	Inboard Pump	91.0	56	25	28				
A5690- *R01 *01 * * -70	Outboard Pump	56.2	12	16	21	1800	600	107.5	128
	Inboard Pump	91.0	56	25	28				
A16145- *R01 *01 * * -60	Outboard Pump	15.8	4	16	21	1800	600	109	134
	Inboard Pump	145	83	25	28				
A22145- *R01 *01 * * -60	Outboard Pump	22.2	6	16	16	1800	600	109	134
	Inboard Pump	145	83	25	28				
A37145- *R01 *01 * * -60	Outboard Pump	36.9	10	16	21	1800	600	121.5	146.5
	Inboard Pump	145	83	25	28				
A56145- *R01 *01 * * -60	Outboard Pump	56.2	12	16	21	1800	600	128.5	153.5
	Inboard Pump	145	83	25	28				

Consult Yuken when detailed material such as dimensions figures is required.

Model Number Designation

A1637	-F	-R	Outboard Pump		Inboard Pump (Driven End)		S	K	-32					
			01	C	01	C								
Series Number	Mounting	Direction of Rotation	Control Type	Pres. Adj. Range MPa	Control Type	Pres. Adj. Range MPa	Port Position of Outboard Pump	Shaft Extension	Design Number					
A1616 (15.8/15.8 cm ³ /rev)	F: Flange Mtg. L: Foot Mtg.	(Viewed from Shaft End) R: Clockwise*1 (Normal)	01: Pressure Compensator Type	B : 1.2- 7 C : 1.2-16 D : 1.2-21	01: Pressure Compensator Type	B : 1.2- 7 C : 1.2-16 D : 1.2-21	S: Side Port None: Axial Port	K: Keyed Shaft	32					
A1622 (15.8/22.2 cm ³ /rev)				B : 1.2- 7 C : 1.2-16		B : 1.2- 7 C : 1.2-16			32					
A2222 (22.2/22.2 cm ³ /rev)				B : 1.2- 7 C : 1.2-16		B : 1.2- 7 C : 1.2-16			32					
A1637 (15.8/36.9 cm ³ /rev)				B : 1.2- 7 C : 1.2-16 H : 1.2-21		B : 1.2- 7 C : 1.2-16 D : 1.2-21			K: Keyed Shaft	32				
A2237 (22.2/36.9 cm ³ /rev)				B : 1.2- 7 C : 1.2-16						32				
A1656 (15.8/56.2 cm ³ /rev)				B : 1.2- 7 C : 1.2-16 H : 1.2-21						32				
A2256 (22.2/56.2 cm ³ /rev)				B : 1.2- 7 C : 1.2-16						32				
A1670 (15.8/70.0 cm ³ /rev)				B : 1.2- 7 C : 1.2-16 H : 1.2-21						None: Keyed Shaft	None: Keyed Shaft	70		
A2270 (22.2/70.0 cm ³ /rev)				B : 1.2- 7 C : 1.2-16								70		
A3770 (36.2/70.0 cm ³ /rev)				B : 1.2- 7 C : 1.2-16 H : 1.2-21								70		
A1690 (15.8/91.0 cm ³ /rev)				B : 1.2- 7 C : 1.2-16 H : 1.2-21								70		
A2290 (22.2/91.0 cm ³ /rev)				B : 1.2- 7 C : 1.2-16								70		
A3790 (36.9/91.0 cm ³ /rev)				B : 1.2- 7 C : 1.5-16 H : 1.8-21 K : 2.0-28								None: Keyed Shaft	None: Keyed Shaft	70
A5690 (56.2/91.0 cm ³ /rev)														B : 1.2- 7 C : 1.2-16 H : 1.2-21
A16145 (15.8/145 cm ³ /rev)	B : 1.2- 7 C : 1.2-16 H : 1.2-21	None: Keyed Shaft	None: Keyed Shaft		60									
A22145 (22.2/145 cm ³ /rev)					B : 1.2- 7 C : 1.2-16		60							
A37145 (36.9/145 cm ³ /rev)					B : 1.2- 7 C : 1.2-16 H : 1.2-21		60							
A56145 (56.2/145 cm ³ /rev)					B : 1.2- 7 C : 1.2-16 H : 1.2-21	60								

*1. Available to supply pump with anti-clockwise rotation. Consult Yuken for details.

Series Piston Pumps – Variable / Fixed Double Pumps

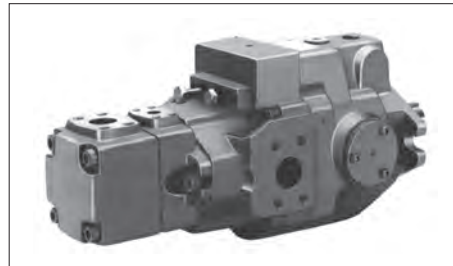

Graphic Symbol

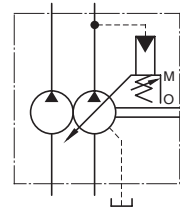

Model Number Designation

A1637	-F	-R	Inboard Pump (Driven End)		Outboard Pump			K	-32						
			01	C	-23	A	A								
Series Number	Mounting	Direction of Rotation	Control Type	Pres. Adj. Range MPa	Nominal Displacement cm ³ /rev	Discharge Port Position	Suction Port Position	Shaft Extension	Design Number						
A16R1	F: Flange Mtg. L: Foot Mtg.	(Viewed from Shaft End) R: Clockwise* ¹ (Normal)	01: Pressure Compensator Type	B: 1.2- 7 C: 1.2-16 D: 1.2-21	6, 8 10, 12 14, 17 19, 23 25, 31	(Viewed from Shaft End) A: Up	A: Up	K: Keyed Shaft	32						
A22R1				B: 1.2- 7 C: 1.2-16					32						
A37R1				B: 1.2- 7 C: 1.2-16 D: 1.2-21					32						
A56R1				B: 1.2- 7 C: 1.2-16 D: 1.2-21					32						
A70R1				L: Foot Mtg.				R: Clockwise* ¹ (Normal)	01: Pressure Compensator Type	B: 1.2- 7 C: 1.5-16 H: 1.8-21 K: 2.0-28	41,47 56,59 65	(Viewed from Shaft End) A: Up	A: Up	None: Keyed Shaft	70
A90R1										B: 1.2- 7 C: 1.5-16 H: 1.8-21 K: 2.0-28					70
A145R1										B: 1.2- 7 C: 1.5-16 H: 1.8-21 K: 2.0-28					60
A70R2										B: 1.2- 7 C: 1.5-16 H: 1.8-21 K: 2.0-28					70
A90R2										B: 1.2- 7 C: 1.5-16 H: 1.8-21 K: 2.0-28					70
A145R2										B: 1.2- 7 C: 1.5-16 H: 1.8-21 K: 2.0-28					60

*1. Available to supply pump with anti-clockwise rotation. Consult Yuken for details.

Consult Yuken when detailed material such as dimensions figures is required.

Specifications

Model Numbers	Geometric Displacement cm ³ /rev	Operating Pressure MPa		Shaft Speed Range r/min		Approx. Mass kg		
		Rated	Intermittent	Max.	Min.	Flange Mtg.	Foot Mtg.	
A16R1- *R01 *-AAK-32	Outboard Pump	Refer to the following table			1800	750	28.8	31.0
	Inboard Pump	15.8	16	21				
A22R1- *R01 *-AAK-32	Outboard Pump	Refer to the following table			1800	750	28.8	31.0
	Inboard Pump	22.2	16	16				
A37R1- *R01 *-AAK-32	Outboard Pump	Refer to the following table			1800	750	39	43.3
	Inboard Pump	36.9	16	21				
A56R1- *R01 *-AAK-32	Outboard Pump	Refer to the following table			1800	750	47	51.3
	Inboard Pump	56.2	16	21				
A70R1- *R01 *-AA-70	Outboard Pump	Refer to the following table			1800	750	66	78
	Inboard Pump	70.0	25	28				
A90R1- *R01 *-AA-70	Outboard Pump	Refer to the following table			1800	750	82	105
	Inboard Pump	91.0	25	28				
A145R1- *R01 *-AA-60	Outboard Pump	Refer to the following table			1800	750	102	129
	Inboard Pump	145	25	28				
A70R2- *R01 *- *AA-70	Outboard Pump	Refer to the following table			1800	600	72.5	84.5
	Inboard Pump	70.0	25	28				
A90R2- *R01 *- *AA-70	Outboard Pump	Refer to the following table			1800	600	91.5	112
	Inboard Pump	91.0	25	28				
A145R2- *R01 *- *AA-60	Outboard Pump	Refer to the following table			1800	600	112	137
	Inboard Pump	145	25	28				

Geometric Displacement and Max. Pressure of Outboard Pump

Model Numbers	Geometric Displacement cm ³ /rev	Max Pres. MPa	
		Anti-Wear Type	R & O Type
A *R1- *R01 *-6	5.8	21	16
A *R1- *R01 *-8	8.0		
A *R1- *R01 *-10	9.4		
A *R1- *R01 *-12	12.2		
A *R1- *R01 *-14	13.7		
A *R1- *R01 *-17	16.6		
A *R1- *R01 *-19	18.6		
A *R1- *R01 *-23	22.7	17.5	
A *R1- *R01 *-25	25.3	15	15
A *R1- *R01 *-31	31.0	12	12
A *R2- *R01 *-26	26.6	21	14
A *R2- *R01 *-33	33.3		
A *R2- *R01 *-41	41.3		
A *R2- *R01 *-47	47.2	20	
A *R2- *R01 *-53	52.5	18	
A *R2- *R01 *-59	58.2	16	
A *R2- *R01 *-65	64.7	14	