

"CJT 7/14 MPa" Series Hydraulic Cylinders

YUKEN's "CJT 7/14 MPa" Series Hydraulic Cylinders are provided with many mounting types so that they can be used for wide use of general purpose industrial machines such as machine tools.

In particular, the cushion mechanism has been improved to achieve smoother stopping characteristics with fewer shocks.

Moreover, Switch-Set "CJT" Series Hydraulic Cylinders with a proximity switch which facilitates detecting a position with a slide proximity switch on the cylinder body is also available.(Refer to page J-69 for details)

- Various mounting types.
- Excellent ability in low speed and high-precision operation.
- Gentle stop characteristics obtained with a smooth cushion effect.

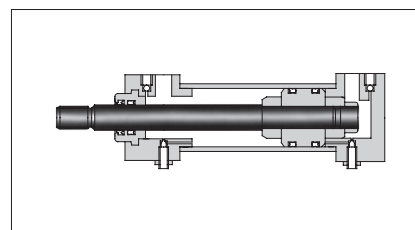
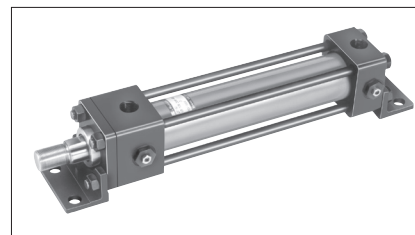

Graphic Symbol

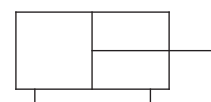

Specifications

Series Number		CJT70	CJT140
Descriptions			
Cylinder Bore	mm	32, 40, 50, 63, 80, 100, 125, 140, 150, 160, 180, 200, 220, 250	
Mounting Type		SD, LA, LB, FA, FB, FC, FD, FE, FF, FY, CA, CB, TA, TC	SD, LA, LB, FC, FD, FE, FF, FY, CA, CB, TA, TC
Nominal Pressure ^{★1}	MPa	7	14 ^{★4}
Maximum Allowable Pressure ^{★1}	Cap Side		9
	Rod Side	Rod Size A	15
		Rod Size B	13.5
	Rod Size C	11	
Proof Test Pressure ^{★1}	MPa	10.5	21
Minimum Working Pressure		0.3 MPa. or less	
Operating Maximum Speed	Cylinder Bore	32 - 63	400
		80 - 125	300
		140 - 250	200
Operating Minimum Speed	mm/s	8	
Maximum Stroke ^{★2}	Cylinder Bore	32	1000
		40,50	1200
		63,80	1600
	100 - 250	2000	
Tolerance of Stroke		Refer to the table "Tolerance of Stroke" ^{★3}	
Tolerance of Thread		JIS B 0211-6g (JIS grade 2 or equivalence)	
Ambient Temperature Range		-10 - +80°C	
Mass	kg	Refer to Page J-22	
Applicable Standard		Compliant with former JIS B8354	

● TC Type Mounting

Minimum Stroke Fabrication Range

Cylinder Bore mm	Minimum Stroke mm
32, 40, 50	15
63	20
80	25
100, 125	15
140 - 250	0

- ★1. Refer to page J-7 for definitions of pressure terms.
- ★2. May be limited to even lower value in accordance with the buckling strength. Refer to page J-23 for strokes above buckling strength.
- ★3. Tolerance of Stroke

Stroke mm	Tolerance mm
100 or less	+0.8 0
More than 100 to 250	+1.0 0
More than 250 to 630	+1.25 0
More than 630 to 1000	+1.4 0
More than 1000 to 1600	+1.6 0
More than 1600 to 2000	+1.8 0

- ★4. In case of the double rod type cylinder, the nominal pressure is limited by the cylinder bore size.

Cylinder Bore	Nominal Pressure MPa	
	Double Rod Main Cover Side	Double Rod Driven Cover Side
32 - 125	14	14
140 - 250	14	7

Model Number Designation

F—	CJT140	—LA	125	B	100	B	—A	B	D	—E	—20
Packing Material	Series Number	Mounting Type	Cylinder Bore mm	Rod Size	Cylinder Stroke mm	Cushion Type	Port Position	Cushion Adj. Valve Position	Air Vent Valve Position	Options	Design Number
None : Nitrile Rubber (standard)	CJT70 : 7MPa Series Standard Cylinder	SD, LA LB, FA FB, FC FD, FE FF, FY CA, CB TA ^{★4} , TC	40, 50 63, 80 100, 125 140, 150 160, 180 200, 220 250	A : Rod A (Super Strong)		B : ^{★3} With Cushion on Both ends R : ^{★3} With Cushion on the Rod side	(Viewed from Rod End) A : Upper (Standard) B : Right D : Left (Standard)	B : Right (Standard) A : Upper C : Under	D : Left (Standard) A : Upper B : Right	Please consult us separately for options for Rod A. E : Long Rod End Thread F : With Dust Cover (Material: Nylon Tarpaulin, Heat resistant up to 80°C) G : With Dust Cover (Material: Chloroprene, Heat resistant up to 130°C) H : With Dust Cover (Material: Sylicon Glass, Heat resistant up to 250°C) K : With Lock Nut (E:Used in combination with long rod end thread) L : With T-End (Rod End Eye) M : With Y-End (Rod End Clevis) N : Double Rod	20
F : Fluoro Rubber	CJT140 : 14MPa Series Standard Cylinder	SD, LA LB, FC FD, FE FF, FY CA, CB TA ^{★4} , TC	32, 40 50, 63 80, 100 125, 140 150, 160 180, 200 220, 250	B : Rod B (Strong) C : Rod C (Standard)	Cylinder Stroke	H : With Cushion on the Cap side N : Without Cushion	D : Left D : Left N : No Cushion adj. valve (Standard)	C : Under C : Under B : Right	C : Under C : Under		

- ★1. Using the options in combination is available. Please specify the option code in the alphabet. Ex.: EKL
However, in case of the double rod type, the options E, F, G, H and K are attached to the both ends. The options L and M are attached at one end only.
Please consult the details about cylinder bore 180 or larger the options L and M with us. (This is a special design products)
- ★2. As for each direction of port, cushion adj. valve and air vent valve, please select from (A)(B)(C)(D) viewed from rod end (see the figure on the right).
<Standard directions>
Port: (A), Cushion adj. valve: (B), Air vent valve: (D)
Note: The direction of port and cushion adj. valve is not available to be the same direction. However, the other combinations are available.

- ★3. Cushion type "B" and "R" are not available for rod size A with cylinder bore 40, 50, 63.
- ★4. Mounting Type TA (Rod Trunnion) cylinder bore 180-250 cannot be selected.
- ★5. Phosphate ester type fluids are also supported. When phosphate ester type are used, prefix "F-" to the model number because the special seals (fluororubber) are required to be used.

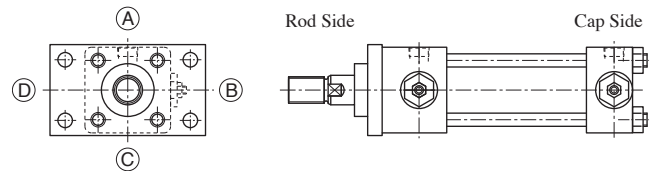

Mounting Type

Code	Name	Illustration of Mounting Type	Code	Name	Illustration of Mounting Type
SD	Basic Type		FD	Cap Square Flange	
LA	Foot Mounting Side Lugs		CA	Cap Detachable Eye	
LB	Foot Mounting Side End Angles		CB	Cap Detachable Clevis	
FA FE FY	Rod Rectangular Flange		TA	Rod Trunnion	
FB FF	Cap Rectangular Flange		TC	Intermediate Trunnion	
FC	Rod Square Flange				

Syllabus Table

● Push (Cap Side Pressure)

Cylinder Bore mm	Pressurised Area cm ²	Output kN					Velocity by a unit flow rate 10L/min mm/s	Flow rate by a unit velocity 10mm/s L/min
		1 MPa	3 MPa	7 MPa	10.5 MPa	14 MPa		
32	8.0	0.80	2.41	5.63	8.44	11.26	208	0.5
40	12.6	1.26	3.77	8.79	13.19	17.58	132	0.8
50	19.6	1.96	5.89	13.74	20.61	27.48	85	1.2
63	31.2	3.12	9.35	21.81	32.71	43.62	53	1.9
80	50.3	5.03	15.07	35.17	52.75	70.34	33	3.0
100	78.5	7.85	23.55	54.95	82.43	109.90	21	4.7
125	122.7	12.27	36.80	85.86	128.79	171.72	14	7.4
140	153.9	15.39	46.16	107.70	161.55	215.40	10.8	9.2
150	176.7	17.67	53.01	123.70	185.55	247.40	9.4	10.6
160	201.0	20.10	60.29	140.67	211.01	281.34	8.3	12.1
180	254.3	25.43	76.30	178.04	267.06	356.08	6.6	15.3
200	314.0	31.40	94.20	219.80	329.70	439.60	5.3	18.8
220	379.9	37.99	113.98	265.96	398.94	531.92	4.4	22.8
250	490.6	49.06	147.19	343.44	515.16	686.88	3.4	29.4

● Pull (Rod Side Pressure)

Cylinder Bore mm	Rod Size Code	Rod Size mm	Pressurised Area cm ²	Output kN					Velocity by a unit flow rate 10L/min mm/s	Flow rate by a unit velocity 10mm/s L/min
				1 MPa	3 MPa	7 MPa	10.5 MPa	14 MPa		
32	B	18	5.5	0.55	1.65	3.85	5.78	7.70	303	0.3
	C	14	6.5	0.65	1.95	4.55	6.83	9.10	256	0.4
40	A	28	6.4	0.64	1.92	4.48	6.72	8.96	260.5	0.4
	B	22	8.8	0.88	2.63	6.13	9.20	12.27	189	0.5
50	C	18	10.0	1.00	3.00	7.00	10.50	14.00	167	0.6
	A	36	9.4	0.94	2.82	6.58	9.87	13.16	177.3	0.6
50	B	28	13.5	1.35	4.04	9.43	14.14	18.86	123	0.8
	C	22	15.8	1.58	4.75	11.08	16.62	22.16	105	0.9
63	A	45	15.3	1.53	4.59	10.71	16.07	21.42	109	0.9
	B	36	21.0	2.10	6.29	14.69	22.03	29.38	79	1.3
63	C	28	25.0	2.50	7.50	17.50	26.25	35.00	67	1.5
	A	56	25.7	2.57	7.71	17.99	26.99	35.98	64.9	1.5
80	B	45	34.3	3.43	10.30	24.04	36.06	48.08	49	2.1
	C	36	40.1	4.01	12.02	28.05	42.07	56.09	42	2.4
100	A	70	40.0	4.00	12.00	28.00	42.00	56.00	41.7	2.4
	B	56	53.9	5.39	16.17	37.72	56.58	75.44	31	3.2
100	C	45	62.6	6.26	18.78	43.82	65.73	87.65	27	3.8
	A	90	59.1	5.91	17.73	41.37	62.06	82.74	28.2	3.5
125	B	70	84.2	8.42	25.26	58.93	88.40	117.87	20	5.1
	C	56	98.0	9.80	29.41	68.63	102.94	137.25	17	5.9
140	A	100	75.4	7.54	22.62	52.78	79.17	105.56	22.1	4.5
	B	80	103.6	10.36	31.09	72.53	108.80	145.07	16	6.2
140	C	63	122.7	12.27	36.81	85.89	128.84	171.78	14	7.4
	A	106	88.5	8.85	26.55	61.95	92.93	123.90	18.8	5.3
150	B	85	120.0	12.00	35.99	83.98	125.97	167.96	13.9	7.2
	C	67	141.5	14.15	42.44	99.02	148.53	198.04	11.8	8.5
160	A	110	106.0	10.60	31.80	74.20	111.30	148.40	15.7	6.4
	B	90	137.4	13.74	41.21	96.16	144.24	192.33	12	8.2
160	C	70	162.5	16.25	48.75	113.75	170.62	227.49	10.3	9.8
	A	125	131.6	13.16	39.48	92.12	138.18	184.24	12.7	7.9
180	B	100	175.8	17.58	52.75	123.09	184.63	246.18	9.5	10.5
	C	80	204.1	20.41	61.23	142.87	214.31	285.74	8.2	12.2
200	A	140	160.1	16.01	48.03	112.07	168.11	224.12	10.4	9.6
	B	110	219.0	21.90	65.70	153.31	229.97	306.62	7.6	13.1
200	C	90	250.4	25.04	75.12	175.29	262.94	350.58	6.7	15.0
	A	160	178.9	17.89	53.67	125.23	187.85	250.46	9.3	10.7
220	B	125	257.3	25.73	77.19	180.10	270.15	360.20	6.5	15.4
	C	100	301.4	30.14	90.43	211.01	316.51	422.02	5.5	18.1
250	A	180	236.3	23.63	70.89	165.41	248.12	330.82	7.1	14.2
	B	140	336.8	33.68	101.03	235.74	353.60	471.47	4.9	20.2
250	C	110	395.6	39.56	118.69	276.95	415.42	553.90	4.2	23.7

"CJT 7/14 MPa" Series

Mass Table

Approx. Mass may be obtained from the formula below.

$$[\text{Mass}] = [\text{Basic Mass}] + \left[\text{Additional Mass By A Unit Stroke 100mm} \times \frac{\text{Stroke (mm)}}{100} \right]$$

Basic mass by mounting type and additional mass by a unit stroke 100 mm

Cylinder Bore	Rod Size Code	Basic Mass kg														Additional Mass By A Unit Stroke 100mm kg
		SD	LA	LB	FA	FB	FC	FD	FE·FY	FF	CA	CB	TA	TC		
32	B	3.3	3.8	3.9	3.5	3.8	3.9	4.2	3.5	3.8	3.9	4.0	3.4	3.8	0.8	
	C	3.2	3.7	3.8	3.4	3.7	3.8	4.1	3.3	3.6	3.8	3.9	3.3	3.7		0.7
40	A	4.4	4.8	4.9	4.7	5.0	5.2	5.4	4.8	5.2	5.0	5.1	4.5	5.0	1.1	
	B	4.2	4.6	4.7	4.5	4.8	5.0	5.2	4.6	5.0	4.8	4.9	4.3	4.8		1.0
	C	4.1	4.5	4.6	4.4	4.7	4.9	5.1	4.5	4.9	4.7	4.8	4.2	4.7		0.9
50	A	7.3	8.1	8.1	7.8	8.4	8.7	9.3	8.3	8.9	8.3	8.5	7.4	8.3	1.7	
	B	6.8	7.6	7.6	7.3	7.9	8.2	8.8	7.8	8.4	7.8	8.0	6.9	7.8		1.3
	C	6.7	7.5	7.5	7.2	7.8	8.1	8.7	7.7	8.3	7.7	7.9	6.8	7.7		1.2
63	A	10.8	11.7	12.4	11.4	12.5	12.7	13.8	12.1	13.1	13.0	13.7	11.2	12.6	2.4	
	B	10.0	10.9	11.6	10.6	11.7	11.9	13.0	11.3	12.3	12.2	12.9	10.4	11.8		1.9
	C	9.9	10.8	11.5	10.5	11.6	11.8	12.9	11.2	12.2	12.1	12.8	10.3	11.7		1.6
80	A	17.0	17.8	19.1	18.0	19.8	19.9	21.6	19.0	20.7	19.8	20.7	17.4	19.2	3.6	
	B	15.6	16.4	17.7	16.6	18.4	18.5	20.2	17.6	19.3	18.4	19.3	16.0	17.8		2.9
	C	15.2	16.0	17.3	16.2	18.0	18.1	19.8	17.2	18.9	18.0	18.9	15.6	17.4		2.4
100	A	28.8	30.0	32.1	30.4	33.4	33.3	36.3	32.2	35.6	34.4	35.9	29.6	33.5	5.6	
	B	26.1	27.3	29.4	27.7	30.7	30.6	33.6	29.5	32.9	31.7	33.2	26.9	30.8		4.4
	C	25.7	26.9	29.0	27.3	30.3	30.2	33.2	29.1	32.5	31.3	32.8	26.5	30.4		3.8
125	A	53.4	55.5	62.5	55.9	61.3	60.7	66.0	59.1	64.4	63.4	66.4	54.0	60.5	8.9	
	B	47.6	49.7	56.7	50.1	55.5	54.9	60.2	53.3	58.6	57.6	60.6	48.2	54.7		7.8
	C	47.2	49.3	56.3	49.7	55.1	54.5	59.8	52.9	58.2	57.2	60.2	47.8	54.3		6.6
140	A	70.5	73.5	83.5	73.6	81.8	80.7	87.0	78.4	85.6	85.6	91.7	72.4	81.2	11.7	
	B	63.0	66.0	76.0	66.1	74.3	73.2	79.5	70.9	78.1	78.1	84.2	64.9	73.7		10.4
	C	60.4	63.4	73.4	63.5	71.7	70.6	76.9	68.3	75.5	75.5	81.6	62.3	71.1		8.9
150	A	82.6	89.1	101.0	88.7	97.4	97.0	105.0	94.6	103.0	99.8	104.5	88.9	96.6	12.7	
	B	73.7	80.2	92.1	79.8	88.5	88.1	96.1	85.7	94.1	90.9	95.6	80.0	87.7		11.2
	C	70.1	76.6	88.5	76.2	84.9	84.5	92.5	82.1	90.5	87.3	92.0	76.4	84.1		9.6
160	A	98.4	102.6	115.2	103.5	114.7	113.0	124.2	109.0	120.2	120.9	129.8	100.7	114.7	13.9	
	B	89.4	93.6	106.2	94.5	105.7	104.0	115.2	100.0	111.2	111.9	120.8	91.7	105.7		12.5
	C	86.1	90.3	102.9	91.2	102.4	100.7	111.9	96.7	107.9	108.6	117.5	88.4	102.4		10.6
180	A	126.1	141.8	159.1	142.6	156.9	155.0	169.2	151.4	165.7	164.4	179.4	—	153.0	19.1	
	B	111.7	127.4	144.7	128.2	142.5	140.6	154.8	137.0	151.3	150.0	165.0	—	138.6		17.9
	C	106.7	122.4	139.7	123.2	137.5	135.6	149.8	132.0	146.3	145.0	160.0	—	133.6		15.7
200	A	162.1	170.7	199.0	172.3	192.2	190.5	210.4	184.3	204.2	209.2	228.6	—	178.0	23.3	
	B	141.5	150.1	178.4	151.7	171.6	169.9	189.8	163.7	183.6	188.6	208.0	—	157.4		21.7
	C	136.4	145.0	173.3	146.6	166.5	164.8	184.7	158.6	178.5	183.5	202.9	—	152.3		19.0
220	A	238.0	247.2	295.0	252.3	279.7	276.4	303.8	270.8	298.2	297.7	322.7	—	273.9	33.8	
	B	208.4	217.6	265.4	222.7	250.1	246.8	274.2	241.2	268.6	268.1	293.1	—	244.3		26.4
	C	198.5	207.7	255.5	212.8	240.2	236.9	264.3	231.3	258.7	258.2	283.2	—	234.4		23.0
250	A	335.7	349.1	416.2	353.2	390.7	385.6	422.8	376.9	415.1	409.4	435.0	—	373.0	40.8	
	B	291.2	304.6	371.7	308.7	346.2	341.1	378.3	332.4	370.6	364.9	390.5	—	328.5		32.8
	C	280.8	294.2	361.3	298.3	335.8	330.7	367.9	322.0	360.2	354.5	380.1	—	318.1		28.4

Tie Rod Tightening

When tightening tie rods, do not tighten only one tie rod tightly at a time, but gradually tighten the tie rods in the order of the numbers shown in the figure on the right. Note that one-sided tightening of tie rods may cause operation failure or chattering.

Bore mm	32	40	50	63	80	100	125
Tightening Torque Nm	18	35	62	100	150	300	550
Bore mm	140	150	160	180	200	220	250
Tightening Torque Nm	800	800	1100	1100	1400	2400	3000

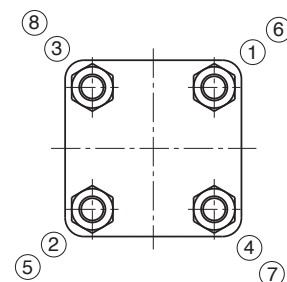

Maximum stroke limited by buckling strength

Calculation of Maximum Stroke

1. Calculate rod end coefficient n from the table on the right.
2. Calculate the maximum installation length L by applying various values such as cylinder bore, rod size, pressure, and rod end coefficient to the figure below.
3. Refer to the external dimensions and calculate the mounting length L_0 when retracted.

Use the formula $S=L-L_0$ and calculate the maximum stroke S .
 (Example) Cylinder bore 100 mm, rod size 56 mm, mounting type TC (intermediate trunnion type) standard cylinder operated at 8 MPa pressure. Calculate the maximum stroke.

From the table on the right $n=1$
 From the figure below $L \cong 1980$
 From Dimensional Drawing (J-37) and Rod End Attachment (J-38)
 $L_0 = (156 + 145) + \frac{S}{2}$
 therefore $S = L - L_0 = 1980 - [(156 + 145) + \frac{S}{2}]$
 hence $S \cong 1120$ mm

Mounting Type	Type	Rod End Coefficient n	Mounting Type	Type	Rod End Coefficient n
LA		1/4	FB		1/4
FA		1/4	TA		1

$S=L-L_0$
 S : Stroke mm
 L : Mounting Length at extension mm
 L_0 : Mounting Length at contraction mm
 Note: For L_0 dimensions, refer to dimensional drawing and add the dimensions of rod end attachment.

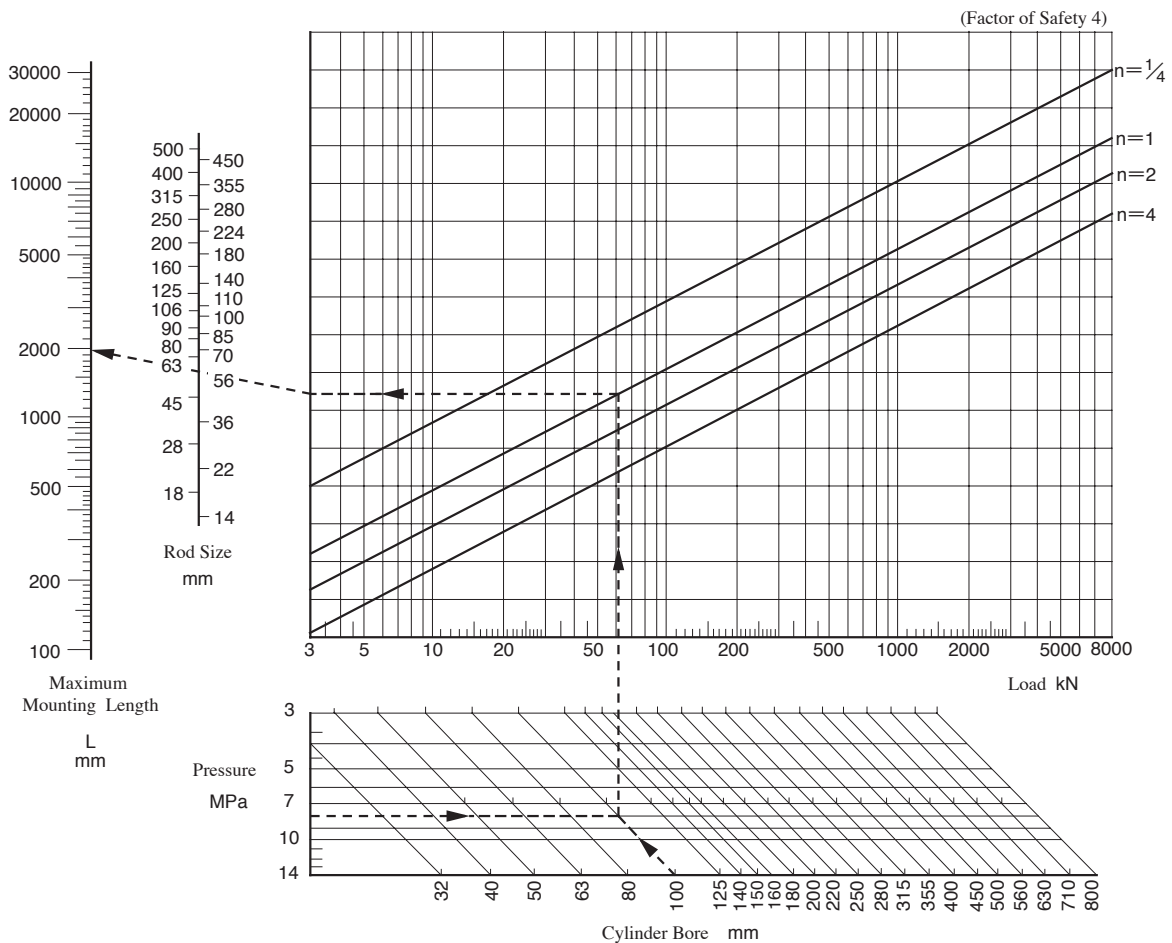

SD : Basic Type.....Nominal Pressure 7 · 14 MPa

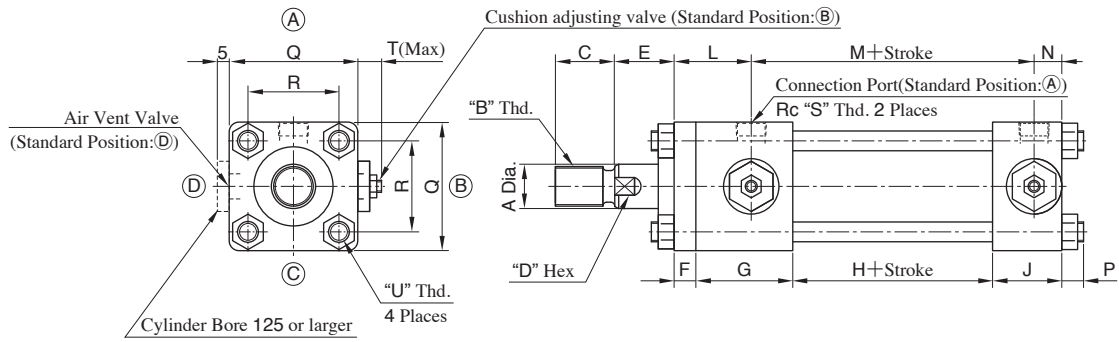

Options

With Dust Cover

Type F: Material: Nylon Tarpaulin, heat resistant up to 80°C
 Type G: Material: Chloroprene, heat resistant up to 130°C
 Type H: Material: Silicon Glass, heat resistant up to 250°C

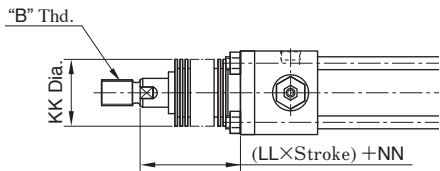

Note : FE type & the other mounting type has difference in dimension "NN".

Double Rod Type "N"

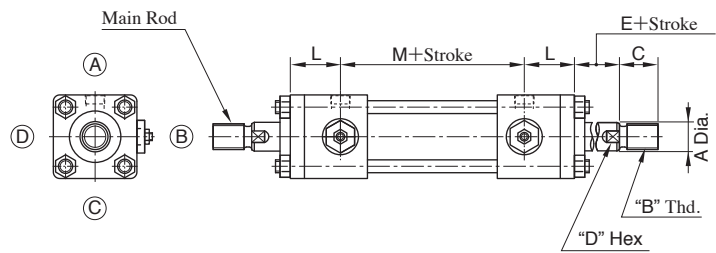

Cylinder Bore	A		B			C*1			D			KK		E	F	G	H	J	L	M	N	P	Q	R	S	T	U	LL*2	NN*3
	Rod Size		Rod Size			Rod Size			Rod Size			Rod Size																	
	"A"	"B"	"C"	"A"	"B"	"C"	"A"	"B"	"C"	"A"	"B"	"C"	"B"																
32	-	18	14	-	M16 x 1.5	M12 x 1.25	-	25 (32)	18 (24)	-	14	12	46	46	30	11	49	46	35	39	88	14	9	58	40	3/8	12	M8 x 1.0	45 (45)
40	28	22	18	M24 x 1.5	M20 x 1.5	M16 x 1.5	35 (48)	30 (40)	25 (32)	24	19	14	52	48	30	11	49	46	35	39	88	14	11	65	45	3/8	12	M10 x 1.25	45 (43)
50	36	28	22	M30 x 1.5	M24 x 1.5	M20 x 1.5	45 (60)	35 (48)	30 (40)	30	24	19	59	52	30	13	56	46	40	44	96	15	13	80	55	1/2	12	M12 x 1.25	45 (40)
63	45	36	28	M39 x 1.5	M30 x 1.5	M24 x 1.5	60 (78)	45 (60)	35 (48)	41	30	24	69	59	35	15	44	70	34	42	104	17	14.5	94	65	1/2	12	M14 x 1.5	55 (50)
80	56	45	36	M48 x 1.5	M39 x 1.5	M30 x 1.5	75 (96)	60 (78)	45 (60)	50	41	30	81	69	35	18	50	78	38	48	118	18	16.5	110	82	3/4	12	M16 x 1.5	55 (49)
100	70	56	45	M64 x 2.0	M48 x 1.5	M39 x 1.5	95 (128)	75 (96)	60 (78)	65	50	41	100	81	40	20	57	74	41	54	120	18	19.5	138	103	3/4	12	M20 x 1.5	55 (47)
125	90	70	56	M80 x 2.0	M64 x 2.0	M48 x 1.5	120 (140)	95 (128)	75 (96)	85	65	50	118	100	45	24	67	78	51	63	134	23	23	168	125	1	15	M24 x 1.5	65 (56)
140	100	80	63	M95 x 2.0	M72 x 2.0	M56 x 2.0	140 (165)	110 (128)	80 (112)	95	75	55	129	106	50	26	67	86	51	65	142	23	25	188	141	1	15	M27 x 1.5	65 (54)
150	106	85	67	M100 x 2.0	M76 x 2.0	M60 x 2.0	150 (175)	115 (128)	85 (120)	100	80	60	135	112	50	28	67	91	54	67	147	26	25	196	148	1	15	M27 x 1.5	65 (54)
160	110	90	70	M100 x 2.0	M80 x 2.0	M64 x 2.0	150 (175)	120 (140)	95 (128)	105	85	65	140	118	55	31	65	98	59	66	158	29	28.5	215	160	1	15	M30 x 1.5	65 (55)
180	125	100	80	M120 x 2.0	M95 x 2.0	M72 x 2.0	180 (210)	140 (165)	110 (128)	120	95	75	151	129	55	33	75	106	61	75	172	28	27	235	182	1 1/4	15	M30 x 1.5	65 (52)
200	140	110	90	M130 x 2.0	M100 x 2.0	M80 x 2.0	195 (225)	150 (175)	120 (140)	135	105	85	170	140	55	37	85	110	69	85	184	32	29	262	200	1 1/2	15	M33 x 1.5	65 (51)
220	160	125	100	M150 x 2.0	M120 x 2.0	M95 x 2.0	225 (260)	180 (210)	140 (175)	155	120	95	183	151	60	41	85	110	69	89	184	32	34	292	225	1 1/2	15	M39 x 1.5	80 (63)
250	180	140	110	M170 x 2.0	M130 x 2.0	M100 x 2.0	255 (295)	195 (225)	150 (175)	175	135	105	205	170	65	46	105	110	85	106	200	40	37	325	250	2	15	M42 x 1.5	80 (61)

*1. Only long rod end thread type : the dimension "C" is the value in parentheses.

*2. If the calculated value of LL x stroke has a fraction less than a whole number, correct (round up) to the nearest 0.5 mm.

*3. NN dimensions are in parentheses only when Mounting Type is FE type.

LA : Foot Mounting Side Lugs.....Nominal Pressure 7 · 14 MPa

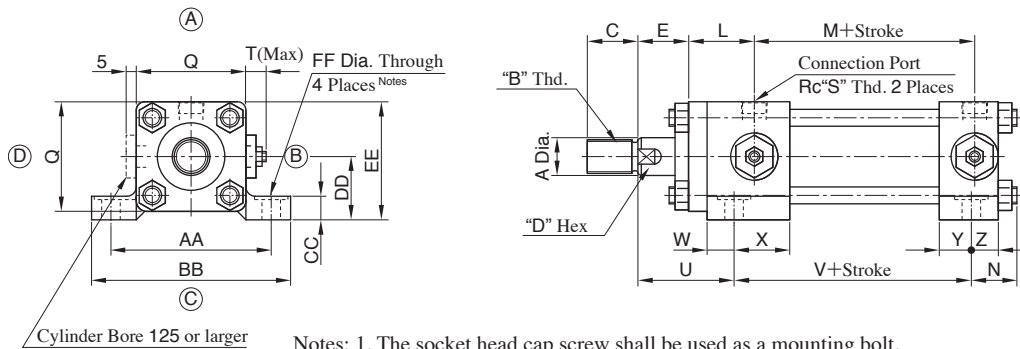

- Notes: 1. The socket head cap screw shall be used as a mounting bolt.
 2. As for cylinder bore 32-100, in case the port direction is "B" or "D", pipe fittings may interference with cylinder mounting bolts. See instructions on page J-4 for details.

Options
 Double Rod Type "N"

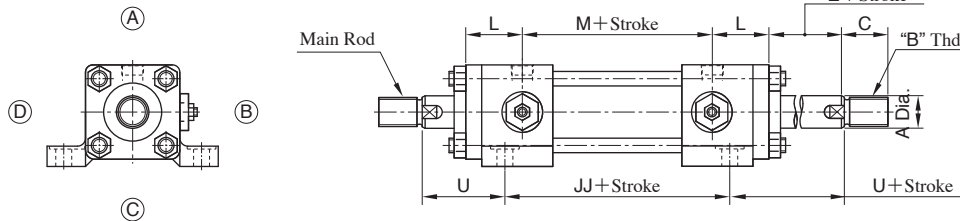

With Dust Cover:
 Refer to SD type page J-24 for dimensions of dust cover.

Cylinder Bore	A			B			C*1			D			E	L	M	N	Q	S	T	U	V	W	X	Y	Z	AA	BB	CC	DD	EE	FF	JJ
	Rod Size			Rod Size			Rod Size			Rod Size																						
	"A"	"B"	"C"	"A"	"B"	"C"	"A"	"B"	"C"	"A"	"B"	"C"																				
32	-	18	14	-	M16 x 1.5	M12 x 1.25	-	25 (32)	18 (24)	-	14	12	30	39	88	25	58	3/8	12	57	98	16	33	19	16	88	109	14	35 ± 0.15	64	11	112
40	28	22	18	M24 x 1.5	M20 x 1.5	M16 x 1.5	35 (48)	30 (40)	25 (32)	24	19	14	30	39	88	27	65	3/8	12	57	98	16	33	19	16	95	118	14	37.5 ± 0.15	70	11	112
50	36	28	22	M30 x 1.5	M24 x 1.5	M20 x 1.5	45 (60)	35 (48)	30 (40)	30	24	19	30	44	96	30	80	1/2	12	60	108	17	39	23	17	115	145	17	45 ± 0.15	85	14	124
63	45	36	28	M39 x 1.5	M30 x 1.5	M24 x 1.5	60 (78)	45 (60)	35 (48)	41	30	24	35	42	104	35	94	1/2	12	71	106	21	23	13	21	132	165	19	50 ± 0.15	97	18	116
80	56	45	36	M48 x 1.5	M39 x 1.5	M30 x 1.5	75 (96)	60 (78)	45 (60)	50	41	30	35	48	118	37	110	3/4	12	74	124	21	29	17	21	155	190	25	60 ± 0.25	115	18	136
100	70	56	45	M64 x 2.0	M48 x 1.5	M39 x 1.5	95 (128)	75 (96)	60 (78)	65	50	41	40	54	120	44	138	3/4	12	85	122	25	32	16	25	190	230	27	71 ± 0.25	140	22	138
125	90	70	56	M80 x 2.0	M64 x 2.0	M48 x 1.5	120 (140)	95 (96)	75 (96)	85	65	50	45	63	134	53	168	1	15	99	136	30	37	21	30	224	272	32	85 ± 0.25	169	26	152
140	100	80	63	M95 x 2.0	M72 x 2.0	M56 x 2.0	140 (165)	110 (128)	80 (112)	95	75	55	50	65	142	55	188	1	15	106	144	30	37	21	30	250	300	35	95 ± 0.25	189	26	160
150	106	85	67	M100 x 2.0	M76 x 2.0	M60 x 2.0	150 (175)	115 (128)	85 (120)	100	80	60	50	67	147	58	196	1	15	111	146	33	34	21	33	270	320	37	106 ± 0.25	204	30	159
160	110	90	70	M100 x 2.0	M80 x 2.0	M64 x 2.0	150 (175)	120 (140)	95 (128)	105	85	65	55	66	158	64	215	1	15	122	150	36	29	23	36	285	345	42	112 ± 0.25	219.5	33	156
180	125	100	80	M120 x 2.0	M95 x 2.0	M72 x 2.0	180 (210)	140 (165)	110 (128)	120	95	75	55	75	172	62	235	1 1/4	15	123	172	35	40	26	35	315	375	47	125 ± 0.25	242.5	33	186
200	140	110	90	M130 x 2.0	M100 x 2.0	M80 x 2.0	195 (225)	150 (175)	120 (140)	135	105	85	55	85	184	68	262	1 1/2	15	131	186	39	46	30	39	355	425	52	140 ± 0.25	271	36	202
220	160	125	100	M150 x 2.0	M120 x 2.0	M95 x 2.0	225 (260)	180 (210)	140 (175)	155	120	95	60	89	184	73	292	1 1/2	15	140	186	39	46	30	39	395	475	52	150 ± 0.25	296	42	202
250	180	140	110	M170 x 2.0	M130 x 2.0	M100 x 2.0	255 (295)	195 (225)	150 (175)	175	135	105	65	106	200	84	325	2	15	158	206	47	58	38	47	425	515	57	170 ± 0.25	332.5	45	226

*1. Only long rod end thread type : the dimension "C" is the value in parentheses.

LB : Foot Mounting Side End Angles.....Nominal Pressure 7 · 14 MPa

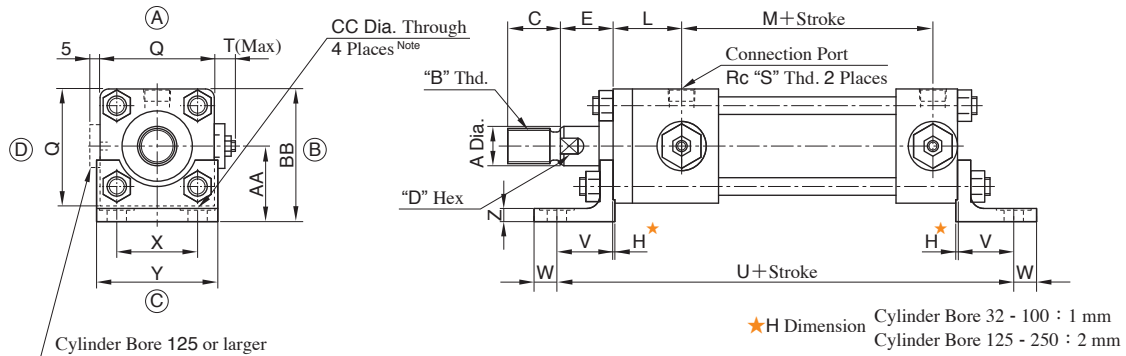

Note: The socket head cap screw shall be used as a mounting bolt.

Options

Double Rod Type "N"

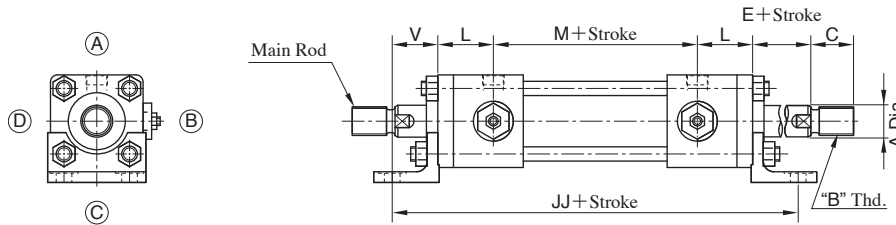

With Dust Cover:

Refer to SD type page J-24 for dimensions of dust cover.

Cylinder Bore	A				B			C ^{★1}			D			E	L	M	Q	S	T	U	V	W	X	Y	Z	AA	BB	CC	JJ
	Rod Size		Rod Size		Rod Size		Rod Size		Rod Size		A	B	C																
	"A"	"B"	"C"	"A"	"B"	"C"	"A"	"B"	"C"	"A"																			
32	-	18	14	-	M16 x 1.5	M12 x 1.25	-	25 (32)	18 (24)	-	14	12	30	39	88	58	3/8	12	205	32	13	40	63	7.5	40 ± 0.15	69	11	230	
40	28	22	18	M24 x 1.5	M20 x 1.5	M16 x 1.5	35 (48)	30 (40)	25 (32)	24	19	14	30	39	88	65	3/8	12	205	32	13	46	69	7.5	43 ± 0.15	75.5	11	230	
50	36	28	22	M30 x 1.5	M24 x 1.5	M20 x 1.5	45 (60)	35 (48)	30 (40)	30	24	19	30	44	96	80	1/2	12	225	35	15	58	85	7.5	50 ± 0.15	90	14	254	
63	45	36	28	M39 x 1.5	M30 x 1.5	M24 x 1.5	60 (78)	45 (60)	35 (48)	41	30	24	35	42	104	94	1/2	12	247	42	18	65	98	11.5	60 ± 0.15	107	18	272	
80	56	45	36	M48 x 1.5	M39 x 1.5	M30 x 1.5	75 (96)	60 (78)	45 (60)	50	41	30	35	48	118	110	3/4	12	284	50	20	87	118	11.5	72 ± 0.25	127	18	314	
100	70	56	45	M64 x 2.0	M48 x 1.5	M39 x 1.5	95 (128)	75 (96)	60 (78)	65	50	41	40	54	120	138	3/4	12	302	55	23	109	150	12.5	85 ± 0.25	154	22	338	
125	90	70	56	M80 x 2.0	M64 x 2.0	M48 x 1.5	120 (140)	95 (128)	75 (96)	85	65	50	45	63	134	168	1	15	352	66	29	130	175	14.5	105 ± 0.25	189	26	397	
140	100	80	63	M95 x 2.0	M72 x 2.0	M56 x 2.0	140 (165)	110 (128)	80 (112)	95	75	55	50	65	142	188	1	15	370	70	30	145	195	17.5	115 ± 0.25	209	26	412	
150	106	85	67	M100 x 2.0	M76 x 2.0	M60 x 2.0	150 (175)	115 (128)	85 (120)	100	80	60	50	67	147	196	1	15	390	75	30	155	210	17.5	123 ± 0.25	221	30	431	
160	110	90	70	M100 x 2.0	M80 x 2.0	M64 x 2.0	150 (175)	120 (140)	95 (128)	105	85	65	55	66	158	215	1	15	403	75	35	170	225	17.5	132 ± 0.25	239.5	33	440	
180	125	100	80	M120 x 2.0	M95 x 2.0	M72 x 2.0	180 (210)	140 (165)	110 (128)	120	95	75	55	75	172	235	1 1/4	15	445	85	40	185	243	19.5	148 ± 0.25	265.5	33	492	
200	140	110	90	M130 x 2.0	M100 x 2.0	M80 x 2.0	195 (225)	150 (175)	120 (140)	135	105	85	55	85	184	262	1 1/2	15	497	98	40	206	272	24.5	165 ± 0.25	296	36	550	
220	160	125	100	M150 x 2.0	M120 x 2.0	M95 x 2.0	225 (260)	180 (210)	140 (175)	155	120	95	60	89	184	292	1 1/2	15	535	115	45	230	310	29.5	185 ± 0.25	331	42	592	
250	180	140	110	M170 x 2.0	M130 x 2.0	M100 x 2.0	255 (295)	195 (225)	150 (175)	175	135	105	65	106	200	325	2	15	606	130	50	250	335	34.5	208 ± 0.25	370.5	45	672	

★1. Only long rod end thread type : the dimension "C" is the value in parentheses.

FA : Rod Rectangular Flange.....Nominal Pressure 7 MPa

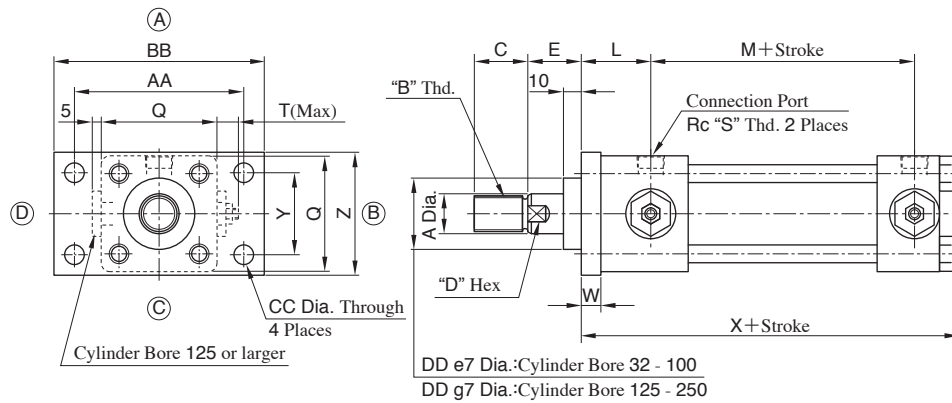

Options

Double Rod Type "N"

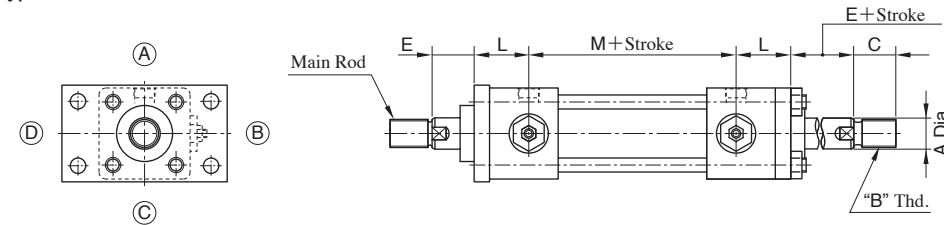

With Dust Cover:

Refer to SD type page J-24 for dimensions of dust cover.

Cylinder Bore	A				B			C★1			D			DD			E	L	M	Q	S	T	W	X	Y	Z	AA	BB	CC
	Rod Size		Rod Size			Rod Size			Rod Size			Rod Size																	
	"A"	"B"	"C"	"A"	"B"	"C"	"A"	"B"	"C"	"A"	"B"	"C"	"A"	"B"	"C"														
32	-	18	14	-	M16 x 1.5	M12 x 1.25	-	25 (32)	18 (24)	-	14	12	-	34	34	30	39	88	58	3/8	12	11	150	40	63	88	109	11	
40	28	22	18	M24 x 1.5	M20 x 1.5	M16 x 1.5	35 (48)	30 (40)	25 (32)	24	19	14	46	40	36	30	39	88	65	3/8	12	11	152	46	69	95	118	11	
50	36	28	22	M30 x 1.5	M24 x 1.5	M20 x 1.5	45 (60)	35 (48)	30 (40)	30	24	19	55	46	40	30	44	96	80	1/2	12	13	168	58	85	115	145	14	
63	45	36	28	M39 x 1.5	M30 x 1.5	M24 x 1.5	60 (78)	45 (60)	35 (48)	41	30	24	65	55	46	35	42	104	94	1/2	12	15	177.5	65	98	132	165	18	
80	56	45	36	M48 x 1.5	M39 x 1.5	M30 x 1.5	75 (96)	60 (78)	45 (60)	50	41	30	80	65	55	35	48	118	110	3/4	12	18	200.5	87	118	155	190	18	
100	70	56	45	M64 x 2.0	M48 x 1.5	M39 x 1.5	95 (128)	75 (96)	60 (78)	65	50	41	95	80	65	40	54	120	138	3/4	12	20	211.5	109	150	190	230	22	
125	90	70	56	M80 x 2.0	M64 x 2.0	M48 x 1.5	120 (140)	95 (128)	75 (96)	85	65	50	115	95	80	45	63	134	168	1	15	24	243	130	175	224	272	26	
140	100	80	63	M95 x 2.0	M72 x 2.0	M56 x 2.0	140 (165)	110 (128)	80 (112)	95	75	55	125	105	85	50	65	142	188	1	15	26	255	145	195	250	300	26	
150	106	85	67	M100 x 2.0	M76 x 2.0	M60 x 2.0	150 (175)	115 (128)	85 (120)	100	80	60	135	110	90	50	67	147	196	1	15	28	265	155	210	270	320	30	
160	110	90	70	M100 x 2.0	M80 x 2.0	M64 x 2.0	150 (175)	120 (140)	95 (128)	105	85	65	140	115	95	55	66	158	215	1	15	31	281.5	170	225	285	345	33	
180	125	100	80	M120 x 2.0	M95 x 2.0	M72 x 2.0	180 (210)	140 (165)	110 (128)	120	95	75	150	125	105	55	75	172	235	1 1/4	15	33	302	185	243	315	375	33	
200	140	110	90	M130 x 2.0	M100 x 2.0	M80 x 2.0	195 (225)	150 (175)	120 (140)	135	105	85	170	140	115	55	85	184	262	1 1/2	15	37	330	206	272	355	425	36	
220	160	125	100	M150 x 2.0	M120 x 2.0	M95 x 2.0	225 (260)	180 (210)	140 (175)	155	120	95	195	150	125	60	89	184	292	1 1/2	15	41	339	230	310	395	475	42	
250	180	140	110	M170 x 2.0	M130 x 2.0	M100 x 2.0	255 (295)	195 (225)	150 (175)	175	135	105	215	170	140	65	106	200	325	2	15	46	383	250	335	425	515	45	

★1. Only long rod end thread type : the dimension "C" is the value in parentheses.

FB : Cap Rectangular Flange.....Nominal Pressure 7 MPa

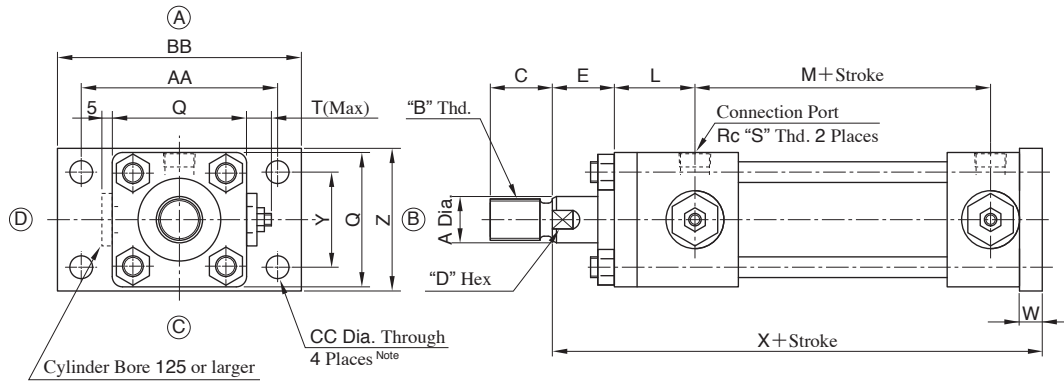

Options

Double Rod Type "N"

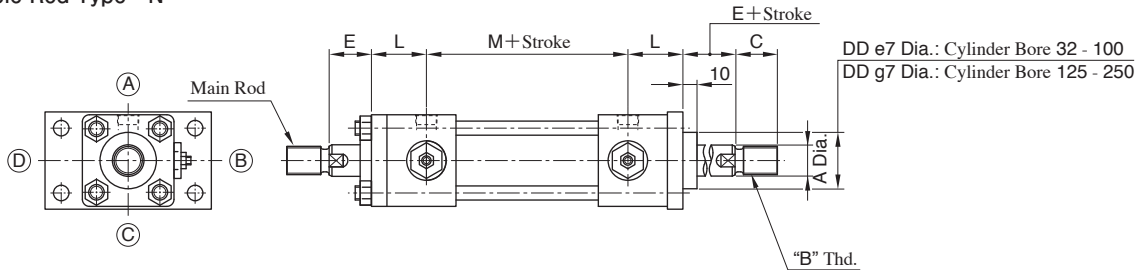

With Dust Cover:

Refer to SD type page J-24 for dimensions of dust cover.

Cylinder Bore	A			B			C*1			D			DD			E	L	M	Q	S	T	W	X	Y	Z	AA	BB	CC
	Rod Size			Rod Size			Rod Size			Rod Size			Rod Size															
	"A"	"B"	"C"	"A"	"B"	"C"	"A"	"B"	"C"	"A"	"B"	"C"	"A"	"B"	"C"													
32	-	18	14	-	M16 x 1.5	M12 x 1.25	-	25 (32)	18 (24)	-	14	12	-	34	34	30	39	88	58	3/8	12	11	182	40	63	88	109	11
40	28	22	18	M24 x 1.5	M20 x 1.5	M16 x 1.5	35 (48)	30 (40)	25 (32)	24	19	14	46	40	36	30	39	88	65	3/8	12	11	182	46	69	95	118	11
50	36	28	22	M30 x 1.5	M24 x 1.5	M20 x 1.5	45 (60)	35 (48)	30 (40)	30	24	19	55	46	40	30	44	96	80	1/2	12	13	198	58	85	115	145	14
63	45	36	28	M39 x 1.5	M30 x 1.5	M24 x 1.5	60 (78)	45 (60)	35 (48)	41	30	24	65	55	46	35	42	104	94	1/2	12	15	213	65	98	132	165	18
80	56	45	36	M48 x 1.5	M39 x 1.5	M30 x 1.5	75 (96)	60 (78)	45 (60)	50	41	30	80	65	55	35	48	118	110	3/4	12	18	237	87	118	155	190	18
100	70	56	45	M64 x 2.0	M48 x 1.5	M39 x 1.5	95 (128)	75 (96)	60 (78)	65	50	41	95	80	65	40	54	120	138	3/4	12	20	252	109	150	190	230	22
125	90	70	56	M80 x 2.0	M64 x 2.0	M48 x 1.5	120 (140)	95 (128)	75 (96)	85	65	50	115	95	80	45	63	134	168	1	15	24	289	130	175	224	272	26
140	100	80	63	M95 x 2.0	M72 x 2.0	M56 x 2.0	140 (165)	110 (128)	80 (112)	95	75	55	125	105	85	50	65	142	188	1	15	26	306	145	195	250	300	26
150	106	85	67	M100 x 2.0	M76 x 2.0	M60 x 2.0	150 (175)	115 (128)	85 (120)	100	80	60	135	110	90	50	67	147	196	1	15	28	318	155	210	270	320	30
160	110	90	70	M100 x 2.0	M80 x 2.0	M64 x 2.0	150 (175)	120 (140)	95 (128)	105	85	65	140	115	95	55	66	158	215	1	15	31	339	170	225	285	345	33
180	125	100	80	M120 x 2.0	M95 x 2.0	M72 x 2.0	180 (210)	140 (165)	110 (128)	120	95	75	150	125	105	55	75	172	235	1 1/4	15	33	363	185	243	315	375	33
200	140	110	90	M130 x 2.0	M100 x 2.0	M80 x 2.0	195 (225)	150 (175)	120 (140)	135	105	85	170	140	115	55	85	184	262	1 1/2	15	37	393	206	272	355	425	36
220	160	125	100	M150 x 2.0	M120 x 2.0	M95 x 2.0	225 (260)	180 (210)	140 (175)	155	120	95	195	150	125	60	89	184	292	1 1/2	15	41	406	230	310	395	475	42
250	180	140	110	M170 x 2.0	M130 x 2.0	M100 x 2.0	255 (295)	195 (225)	150 (175)	175	135	105	215	170	140	65	106	200	325	2	15	46	457	250	335	425	515	45

*1. Only long rod end thread type : the dimension "C" is the value in parentheses.

FC : Rod Square Flange.....Nominal Pressure 7 · 14 MPa

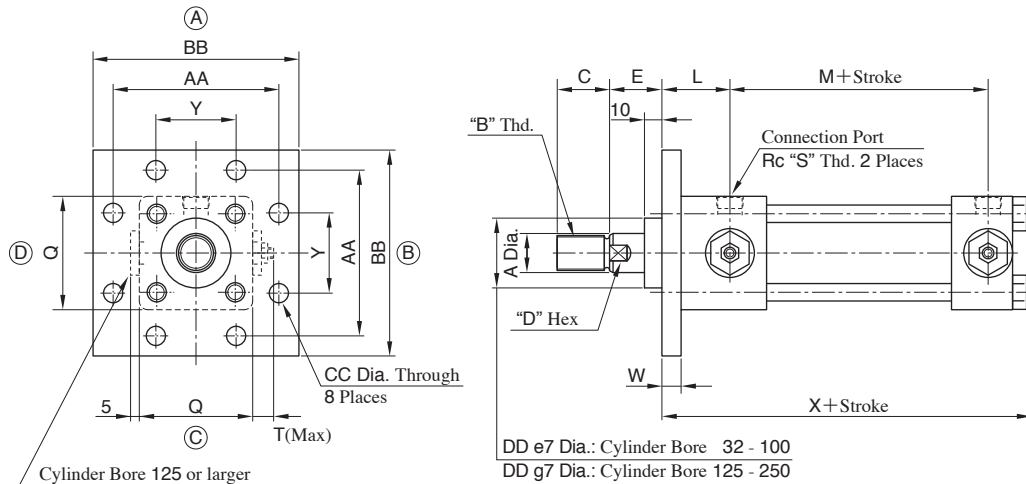

Options

Double Rod Type "N"

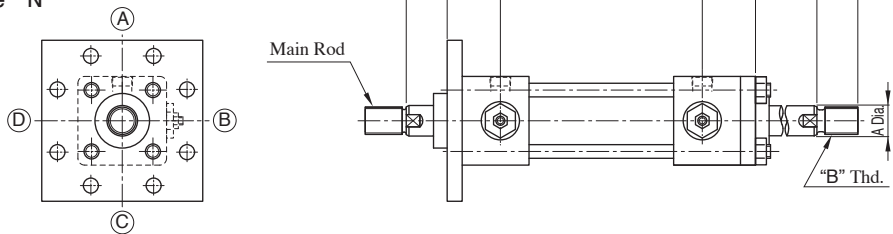

With Dust Cover:

Refer to SD type page J-24 for dimensions of dust cover.

Cylinder Bore	A				B			C*1			D			DD			E	L	M	Q	S	T	W	X	Y	AA	BB	CC
	Rod Size				Rod Size			Rod Size			Rod Size			Rod Size														
	"A"	"B"	"C"		"A"	"B"	"C"	"A"	"B"	"C"	"A"	"B"	"C"	"A"	"B"	"C"												
32	-	18	14	-	M16 x 1.5	M12 x 1.25	-	25 (32)	18 (24)	-	14	12	-	34	34	30	39	88	58	3/8	12	11	150	40	88	109	11	
40	28	22	18	M24 x 1.5	M20 x 1.5	M16 x 1.5	35 (48)	30 (40)	25 (32)	24	19	14	46	40	36	30	39	88	65	3/8	12	11	152	46	95	118	11	
50	36	28	22	M30 x 1.5	M24 x 1.5	M20 x 1.5	45 (60)	35 (48)	30 (40)	30	24	19	55	46	40	30	44	96	80	1/2	12	13	168	58	115	145	14	
63	45	36	28	M39 x 1.5	M30 x 1.5	M24 x 1.5	60 (78)	45 (60)	35 (48)	41	30	24	65	55	46	35	42	104	94	1/2	12	15	177.5	65	132	165	18	
80	56	45	36	M48 x 1.5	M39 x 1.5	M30 x 1.5	75 (96)	60 (78)	45 (60)	50	41	30	80	65	55	35	48	118	110	3/4	12	18	200.5	87	155	190	18	
100	70	56	45	M64 x 2.0	M48 x 1.5	M39 x 1.5	95 (128)	75 (96)	60 (78)	65	50	41	95	80	65	40	54	120	138	3/4	12	20	211.5	109	190	230	22	
125	90	70	56	M80 x 2.0	M64 x 2.0	M48 x 1.5	120 (140)	95 (128)	75 (96)	85	65	50	115	95	80	45	63	134	168	1	15	24	243	130	224	272	26	
140	100	80	63	M95 x 2.0	M72 x 2.0	M56 x 2.0	140 (165)	110 (128)	80 (112)	95	75	55	125	105	85	50	65	142	188	1	15	26	255	145	250	300	26	
150	106	85	67	M100 x 2.0	M76 x 2.0	M60 x 2.0	150 (175)	115 (128)	85 (120)	100	80	60	135	110	90	50	67	147	196	1	15	28	265	155	270	320	30	
160	110	90	70	M100 x 2.0	M80 x 2.0	M64 x 2.0	150 (175)	120 (140)	95 (128)	105	85	65	140	115	95	55	66	158	215	1	15	31	281.5	170	285	345	33	
180	125	100	80	M120 x 2.0	M95 x 2.0	M72 x 2.0	180 (210)	140 (165)	110 (128)	120	95	75	150	125	105	55	75	172	235	1 1/4	15	33	302	185	315	375	33	
200	140	110	90	M130 x 2.0	M100 x 2.0	M80 x 2.0	195 (225)	150 (175)	120 (140)	135	105	85	170	140	115	55	85	184	262	1 1/2	15	37	330	206	355	425	36	
220	160	125	100	M150 x 2.0	M120 x 2.0	M95 x 2.0	225 (260)	180 (210)	140 (175)	155	120	95	195	150	125	60	89	184	292	1 1/2	15	41	339	230	395	475	42	
250	180	140	110	M170 x 2.0	M130 x 2.0	M100 x 2.0	255 (295)	195 (225)	150 (175)	175	135	105	215	170	140	65	106	200	325	2	15	46	383	250	425	515	45	

*1. Only long rod end thread type : the dimension "C" is the value in parentheses.

FD : Cap Square Flange.....Nominal Pressure 7 · 14 MPa

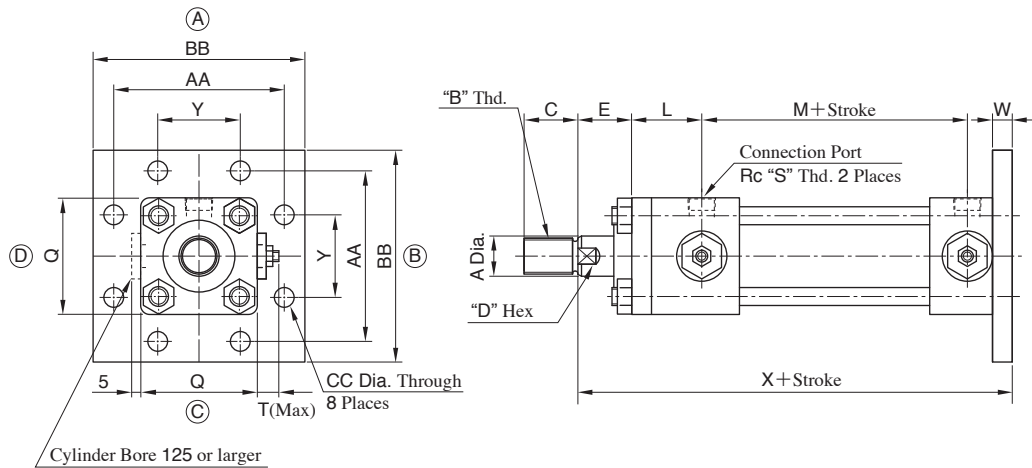

Options

Double Rod Type "N"

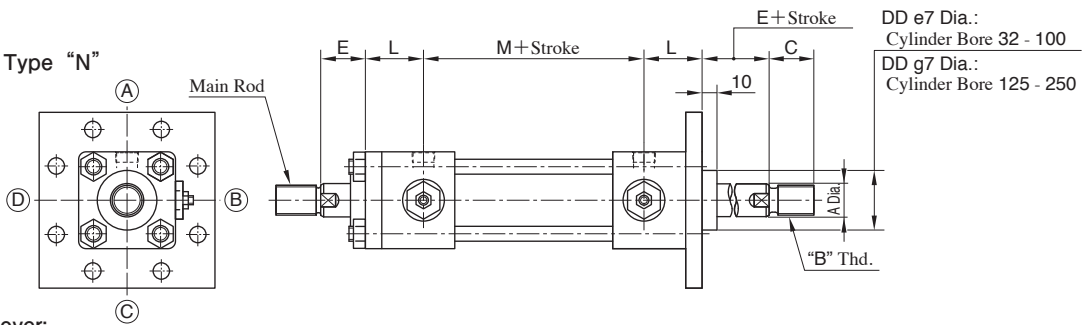

With Dust Cover:

Refer to SD type page J-24 for dimensions of dust cover.

Cylinder Bore	A				B			C*1			D			DD			E	L	M	Q	S	T	W	X	Y	AA	BB	CC
	Rod Size		Rod Size			Rod Size			Rod Size			Rod Size																
	"A"	"B"	"C"	"A"	"B"	"C"	"A"	"B"	"C"	"A"	"B"	"C"	"A"	"B"	"C"													
32	-	18	14	-	M16 x 1.5	M12 x 1.25	-	25 (32)	18 (24)	-	14	12	-	34	34	30	39	88	58	3/8	12	11	182	40	88	109	11	
40	28	22	18	M24 x 1.5	M20 x 1.5	M16 x 1.5	35 (48)	30 (40)	25 (32)	24	19	14	46	40	36	30	39	88	65	3/8	12	11	182	46	95	118	11	
50	36	28	22	M30 x 1.5	M24 x 1.5	M20 x 1.5	45 (60)	35 (48)	30 (40)	30	24	19	55	46	40	30	44	96	80	1/2	12	13	198	58	115	145	14	
63	45	36	28	M39 x 1.5	M30 x 1.5	M24 x 1.5	60 (78)	45 (60)	35 (48)	41	30	24	65	55	46	35	42	104	94	1/2	12	15	213	65	132	165	18	
80	56	45	36	M48 x 1.5	M39 x 1.5	M30 x 1.5	75 (96)	60 (78)	45 (60)	50	41	30	80	65	55	35	48	118	110	3/4	12	18	237	87	155	190	18	
100	70	56	45	M64 x 2.0	M48 x 1.5	M39 x 1.5	95 (128)	75 (96)	60 (78)	65	50	41	95	80	65	40	54	120	138	3/4	12	20	252	109	190	230	22	
125	90	70	56	M80 x 2.0	M64 x 2.0	M48 x 1.5	120 (140)	95 (128)	75 (96)	85	65	50	115	95	80	45	63	134	168	1	15	24	289	130	224	272	26	
140	100	80	63	M95 x 2.0	M72 x 2.0	M56 x 2.0	140 (165)	110 (128)	80 (112)	95	75	55	125	105	85	50	65	142	188	1	15	26	306	145	250	300	26	
150	106	85	67	M100 x 2.0	M76 x 2.0	M60 x 2.0	150 (175)	115 (128)	85 (120)	100	80	60	135	110	90	50	67	147	196	1	15	28	318	155	270	320	30	
160	110	90	70	M100 x 2.0	M80 x 2.0	M64 x 2.0	150 (175)	120 (140)	95 (128)	105	85	65	140	115	95	55	66	158	215	1	15	31	339	170	285	345	33	
180	125	100	80	M120 x 2.0	M95 x 2.0	M72 x 2.0	180 (210)	140 (165)	110 (128)	120	95	75	150	125	105	55	75	172	235	1 1/4	15	33	363	185	315	375	33	
200	140	110	90	M130 x 2.0	M100 x 2.0	M80 x 2.0	195 (225)	150 (175)	120 (140)	135	105	85	170	140	115	55	85	184	262	1 1/2	15	37	393	206	355	425	36	
220	160	125	100	M150 x 2.0	M120 x 2.0	M95 x 2.0	225 (260)	180 (210)	140 (175)	155	120	95	195	150	125	60	89	184	292	1 1/2	15	41	406	230	395	475	42	
250	180	140	110	M170 x 2.0	M130 x 2.0	M100 x 2.0	255 (295)	195 (225)	150 (175)	175	135	105	215	170	140	65	106	200	325	2	15	46	457	250	425	515	45	

*1. Only long rod end thread type : the dimension "C" is the value in parentheses.

FE : Rod Rectangular Flange.....Nominal Pressure 7 · 14 MPa

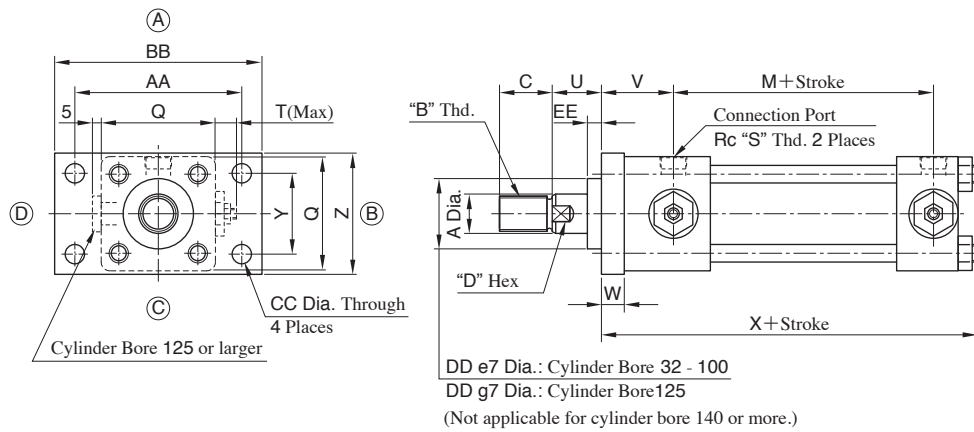

Options

Double Rod Type "N"

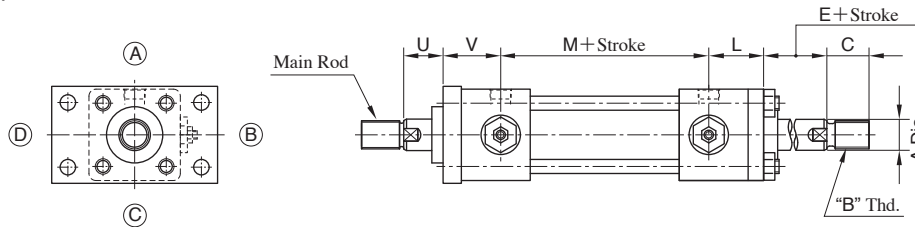

With Dust Cover:

Refer to SD type page J-24 for dimensions of dust cover.

Cylinder Bore	A			B			C*1			D			DD			E	L	M	Q	S	T	U	V	W	X	Y	Z	AA	BB	CC	EE
	Rod Size			Rod Size			Rod Size			Rod Size			Rod Size																		
	"A"	"B"	"C"	"A"	"B"	"C"	"A"	"B"	"C"	"A"	"B"	"C"	"A"	"B"	"C"																
32	-	18	14	-	M16 x 1.5	M12 x 1.25	-	25 (32)	18 (24)	-	14	12	-	34	34	30	39	88	58	3/8	12	28	41	13	152	40	63	88	109	11	8
40	28	22	18	M24 x 1.5	M20 x 1.5	M16 x 1.5	35 (48)	30 (40)	25 (32)	24	19	14	46	40	36	30	39	88	65	3/8	12	28	41	13	154	46	69	95	118	11	8
50	36	28	22	M30 x 1.5	M24 x 1.5	M20 x 1.5	45 (60)	35 (48)	30 (40)	30	24	19	55	46	40	30	44	96	80	1/2	12	25	49	18	173	58	85	115	145	14	5
63	45	36	28	M39 x 1.5	M30 x 1.5	M24 x 1.5	60 (78)	45 (60)	35 (48)	41	30	24	65	55	46	35	42	104	94	1/2	12	30	47	20	182.5	65	98	132	165	18	5
80	56	45	36	M48 x 1.5	M39 x 1.5	M30 x 1.5	75 (96)	60 (78)	45 (60)	50	41	30	80	65	55	35	48	118	110	3/4	12	29	54	24	206.5	87	118	155	190	18	4
100	70	56	45	M64 x 2.0	M48 x 1.5	M39 x 1.5	95 (128)	75 (96)	60 (78)	65	50	41	95	80	65	40	54	120	138	3/4	12	32	62	28	219.5	109	150	190	230	22	2
125	90	70	56	M80 x 2.0	M64 x 2.0	M48 x 1.5	120 (140)	95 (128)	75 (96)	85	65	50	115	95	80	45	63	134	168	1	15	36	72	33	252	130	175	224	272	26	1
140	100	80	63	M95 x 2.0	M72 x 2.0	M56 x 2.0	140 (165)	110 (128)	80 (112)	95	75	55	-	-	-	50	65	142	188	1	15	39	76	37	266	145	195	250	300	26	-
150	106	85	67	M100 x 2.0	M76 x 2.0	M60 x 2.0	150 (175)	115 (128)	85 (120)	100	80	60	-	-	-	50	67	147	196	1	15	39	78	39	276	155	210	270	320	30	-
160	110	90	70	M100 x 2.0	M80 x 2.0	M64 x 2.0	150 (175)	120 (140)	95 (128)	105	85	65	-	-	-	55	66	158	215	1	15	45	76	41	291.5	170	225	285	345	33	-
180	125	100	80	M120 x 2.0	M95 x 2.0	M72 x 2.0	180 (210)	140 (165)	110 (128)	120	95	75	-	-	-	55	75	172	235	1 1/4	15	42	88	46	315	185	243	315	375	33	-
200	140	110	90	M130 x 2.0	M100 x 2.0	M80 x 2.0	195 (225)	150 (175)	120 (140)	135	105	85	-	-	-	55	85	184	262	1 1/2	15	41	99	51	344	206	272	355	425	36	-
220	160	125	100	M150 x 2.0	M120 x 2.0	M95 x 2.0	225 (260)	180 (210)	140 (175)	155	120	95	-	-	-	60	89	184	292	1 1/2	15	43	106	58	356	230	310	395	475	42	-
250	180	140	110	M170 x 2.0	M130 x 2.0	M100 x 2.0	255 (295)	195 (225)	150 (175)	175	135	105	-	-	-	65	106	200	325	2	15	46	125	65	402	250	335	425	515	45	-

*1. Only long rod end thread type : the dimension "C" is the value in parentheses.

FY : Rod Rectangular Flange.....Nominal Pressure 7 · 14 MPa

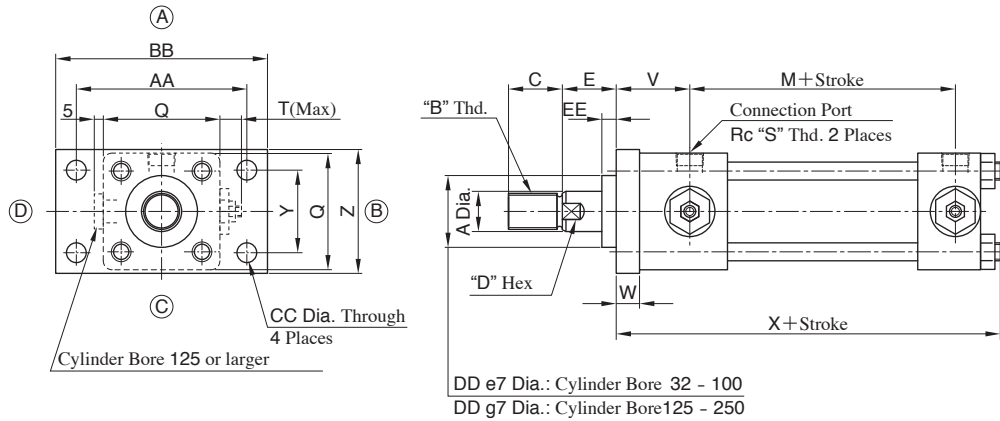

Options

Double Rod Type "N"

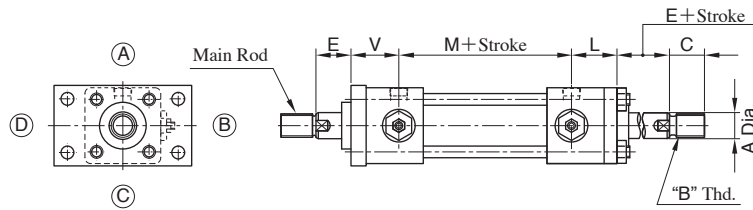

With Dust Cover:

Refer to SD type page J-24 for dimensions of dust cover.

Cylinder Bore	A			B			C*1			D			DD			E	L	M	Q	S	T	V	W	X	Y	Z	AA	BB	CC	EE
	Rod Size			Rod Size			Rod Size			Rod Size			Rod Size																	
	"A"	"B"	"C"	"A"	"B"	"C"	"A"	"B"	"C"	"A"	"B"	"C"	"A"	"B"	"C"															
32	-	18	14	-	M16 x 1.5	M12 x 1.25	-	25 (32)	18 (24)	-	14	12	-	34	34	30	39	88	58	3/8	12	41	13	152	40	63	88	109	11	8
40	28	22	18	M24 x 1.5	M20 x 1.5	M16 x 1.5	35 (48)	30 (40)	25 (32)	24	19	14	46	40	36	30	39	88	65	3/8	12	41	13	154	46	69	95	118	11	8
50	36	28	22	M30 x 1.5	M24 x 1.5	M20 x 1.5	45 (60)	35 (48)	30 (40)	30	24	19	55	46	40	30	44	96	80	1/2	12	49	18	173	58	85	115	145	14	10
63	45	36	28	M39 x 1.5	M30 x 1.5	M24 x 1.5	60 (78)	45 (60)	35 (48)	41	30	24	65	55	46	35	42	104	94	1/2	12	47	20	182.5	65	98	132	165	18	10
80	56	45	36	M48 x 1.5	M39 x 1.5	M30 x 1.5	75 (96)	60 (78)	45 (60)	50	41	30	80	65	55	35	48	118	110	3/4	12	54	24	206.5	87	118	155	190	18	10
100	70	56	45	M64 x 2.0	M48 x 1.5	M39 x 1.5	95 (128)	75 (96)	60 (78)	65	50	41	95	80	65	40	54	120	138	3/4	12	62	28	219.5	109	150	190	230	22	10
125	90	70	56	M80 x 2.0	M64 x 2.0	M48 x 1.5	120 (140)	95 (128)	75 (96)	85	65	50	115	95	80	45	63	134	168	1	15	72	33	252	130	175	224	272	26	10
140	100	80	63	M95 x 2.0	M72 x 2.0	M56 x 2.0	140 (165)	110 (128)	80 (112)	95	75	55	125	105	85	50	65	142	188	1	15	76	37	266	145	195	250	300	26	10
150	106	85	67	M100 x 2.0	M76 x 2.0	M60 x 2.0	150 (175)	115 (128)	85 (120)	100	80	60	135	110	90	50	67	147	196	1	15	78	39	276	155	210	270	320	30	10
160	110	90	70	M100 x 2.0	M80 x 2.0	M64 x 2.0	150 (175)	120 (140)	95 (128)	105	85	65	140	115	95	55	66	158	215	1	15	76	41	291.5	170	225	285	345	33	10
180	125	100	80	M120 x 2.0	M95 x 2.0	M72 x 2.0	180 (210)	140 (165)	110 (128)	120	95	75	150	125	105	55	75	172	235	1 1/4	15	88	46	315	185	243	315	375	33	10
200	140	110	90	M130 x 2.0	M100 x 2.0	M80 x 2.0	195 (225)	150 (175)	120 (140)	135	105	85	170	140	115	55	85	184	262	1 1/2	15	99	51	344	206	272	355	425	36	10
220	160	125	100	M150 x 2.0	M120 x 2.0	M95 x 2.0	225 (260)	180 (210)	140 (175)	155	120	95	195	150	125	60	89	184	292	1 1/2	15	106	58	356	230	310	395	475	42	10
250	180	140	110	M170 x 2.0	M130 x 2.0	M100 x 2.0	255 (295)	195 (225)	150 (175)	175	135	105	215	170	140	65	106	200	325	2	15	125	65	402	250	335	425	515	45	10

*1. Only long rod end thread type : the dimension "C" is the value in parentheses.

FF : Cap Rectangular Flange.....Nominal Pressure 7 · 14 MPa

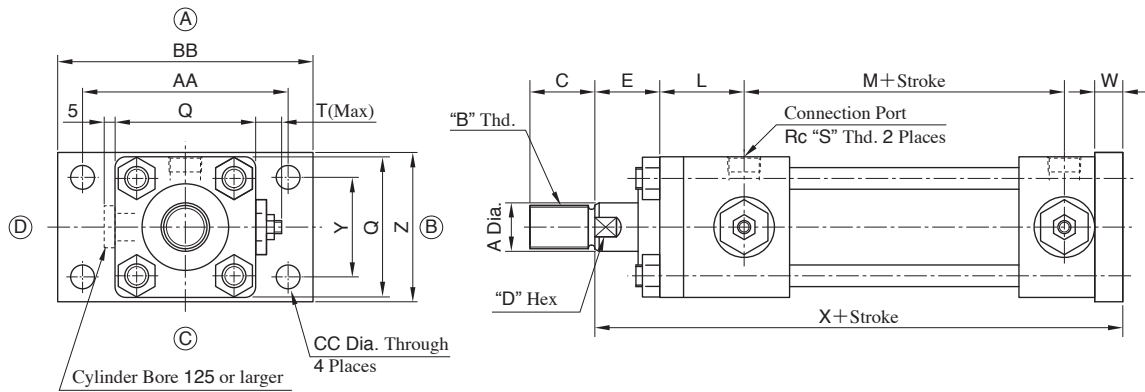

Options

Double Rod Type "N"

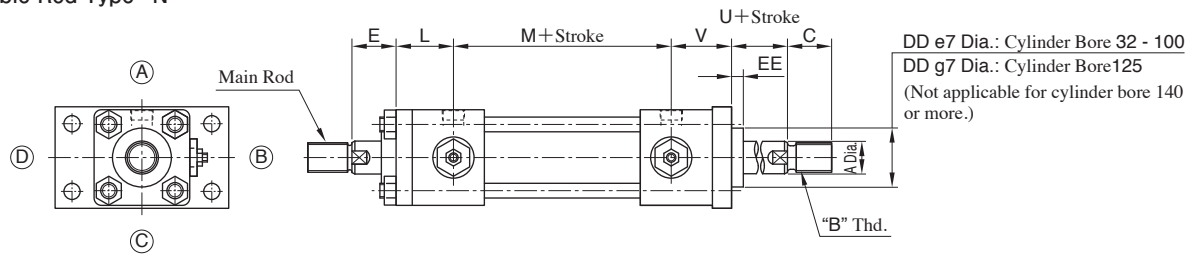

With Dust Cover:

Refer to SD type page J-24 for dimensions of dust cover.

Cylinder Bore	A			B			C*1			D			DD		E	L	M	Q	S	T	U	V	W	X	Y	Z	AA	BB	CC	EE
	Rod Size			Rod Size			Rod Size			Rod Size			Rod Size																	
	"A"	"B"	"C"	"A"	"B"	"C"	"A"	"B"	"C"	"A"	"B"	"C"	"B"	"C"																
32	-	18	14	-	M16 x 1.5	M12 x 1.25	-	25 (32)	18 (24)	-	14	12	34	34	30	39	88	58	3/8	12	28	41	13	184	40	63	88	109	11	8
40	28	22	18	M24 x 1.5	M20 x 1.5	M16 x 1.5	35 (48)	30 (32)	25 (32)	24	19	14	40	36	30	39	88	65	3/8	12	28	41	13	184	46	69	95	118	11	8
50	36	28	22	M30 x 1.5	M24 x 1.5	M20 x 1.5	45 (60)	35 (48)	30 (40)	30	24	19	46	40	30	44	96	80	1/2	12	25	49	18	203	58	85	115	145	14	5
63	45	36	28	M39 x 1.5	M30 x 1.5	M24 x 1.5	60 (78)	45 (60)	35 (48)	41	30	24	55	46	35	42	104	94	1/2	12	30	47	20	218	65	98	132	165	18	5
80	56	45	36	M48 x 1.5	M39 x 1.5	M30 x 1.5	75 (96)	60 (78)	45 (60)	50	41	30	65	55	35	48	118	110	3/4	12	29	54	24	243	87	118	155	190	18	4
100	70	56	45	M64 x 2.0	M48 x 1.5	M39 x 1.5	95 (128)	75 (96)	60 (78)	65	50	41	80	65	40	54	120	138	3/4	12	32	62	28	260	109	150	190	230	22	2
125	90	70	56	M80 x 2.0	M64 x 2.0	M48 x 1.5	120 (140)	95 (128)	75 (96)	85	65	50	95	80	45	63	134	168	1	15	36	72	33	298	130	175	224	272	26	1
140	100	80	63	M95 x 2.0	M72 x 2.0	M56 x 2.0	140 (165)	110 (128)	80 (112)	95	75	55	-	-	50	65	142	188	1	15	39	76	37	317	145	195	250	300	26	-
150	106	85	67	M100 x 2.0	M76 x 2.0	M60 x 2.0	150 (175)	115 (128)	85 (120)	100	80	60	-	-	50	67	147	196	1	15	39	78	39	329	155	210	270	320	30	-
160	110	90	70	M100 x 2.0	M80 x 2.0	M64 x 2.0	150 (175)	120 (140)	95 (128)	105	85	65	-	-	55	66	158	215	1	15	45	76	41	349	170	225	285	345	33	-
180	125	100	80	M120 x 2.0	M95 x 2.0	M72 x 2.0	180 (210)	140 (165)	110 (128)	120	95	75	-	-	55	75	172	235	1 1/4	15	42	88	46	376	185	243	315	375	33	-
200	140	110	90	M130 x 2.0	M100 x 2.0	M80 x 2.0	195 (225)	150 (175)	120 (140)	135	105	85	-	-	55	85	184	262	1 1/2	15	41	99	51	407	206	272	355	425	36	-
220	160	125	100	M150 x 2.0	M120 x 2.0	M95 x 2.0	225 (260)	180 (210)	140 (175)	155	120	95	-	-	60	89	184	292	1 1/2	15	43	106	58	423	230	310	395	475	42	-
250	180	140	110	M170 x 2.0	M130 x 2.0	M100 x 2.0	255 (295)	195 (225)	150 (175)	175	135	105	-	-	65	106	200	325	2	15	46	125	65	476	250	335	425	515	45	-

*1. Only long rod end thread type : the dimension "C" is the value in parentheses.

CA : Cap Detachable Eye.....Nominal Pressure 7 · 14 MPa

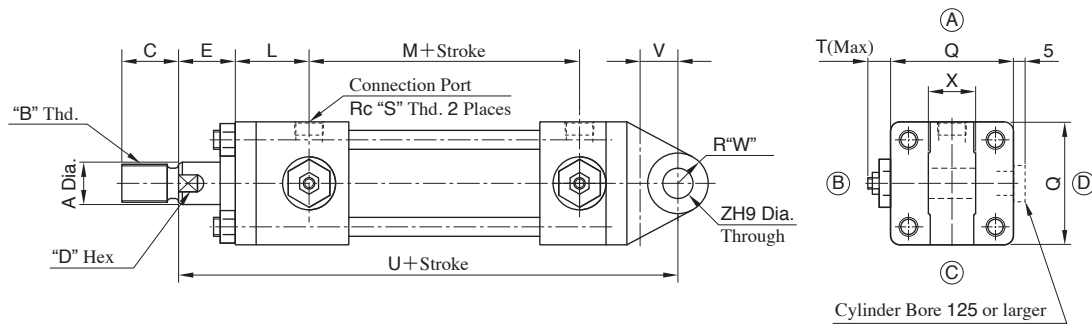

Options

With Dust Cover:

Refer to SD type page J-24 for dimensions of dust cover.

Cylinder Bore	A			B			C*1			D			E	L	M	Q	S	T	U	V	W	X	Z
	Rod Size			Rod Size			Rod Size			Rod Size													
	"A"	"B"	"C"	"A"	"B"	"C"	"A"	"B"	"C"	"A"	"B"	"C"											
32	-	18	14	-	M16 x 1.5	M12 x 1.25	-	25 (32)	18 (24)	-	14	12	30	39	88	58	3/8	12	209	20	16	25 ^{-0.1} _{-0.4}	16
40	28	22	18	M24 x 1.5	M20 x 1.5	M16 x 1.5	35 (48)	30 (40)	25 (32)	24	19	14	30	39	88	65	3/8	12	209	20	16	25 ^{-0.1} _{-0.4}	16
50	36	28	22	M30 x 1.5	M24 x 1.5	M20 x 1.5	45 (60)	35 (48)	30 (40)	30	24	19	30	44	96	80	1/2	12	230	25	20	31.5 ^{-0.1} _{-0.4}	20
63	45	36	28	M39 x 1.5	M30 x 1.5	M24 x 1.5	60 (78)	45 (60)	35 (48)	41	30	24	35	42	104	94	1/2	12	261	40	31.5	40 ^{-0.1} _{-0.4}	31.5
80	56	45	36	M48 x 1.5	M39 x 1.5	M30 x 1.5	75 (96)	60 (78)	45 (60)	50	41	30	35	48	118	110	3/4	12	291	40	31.5	40 ^{-0.1} _{-0.4}	31.5
100	70	56	45	M64 x 2.0	M48 x 1.5	M39 x 1.5	95 (128)	75 (96)	60 (78)	65	50	41	40	54	120	138	3/4	12	316	50	40	50 ^{-0.1} _{-0.4}	40
125	90	70	56	M80 x 2.0	M64 x 2.0	M48 x 1.5	120 (140)	95 (128)	75 (96)	85	65	50	45	63	134	168	1	15	365	62	55	63 ^{-0.1} _{-0.4}	50
140	100	80	63	M95 x 2.0	M72 x 2.0	M56 x 2.0	140 (165)	110 (128)	80 (112)	95	75	55	50	65	142	188	1	15	400	79	65	80 ^{-0.1} _{-0.6}	63
150	106	85	67	M100 x 2.0	M76 x 2.0	M60 x 2.0	150 (175)	115 (128)	85 (120)	100	80	60	50	67	147	196	1	15	412	82	65	80 ^{-0.1} _{-0.6}	63
160	110	90	70	M100 x 2.0	M80 x 2.0	M64 x 2.0	150 (175)	120 (140)	95 (128)	105	85	65	55	66	158	215	1	15	445	89	75	80 ^{-0.1} _{-0.6}	71
180	125	100	80	M120 x 2.0	M95 x 2.0	M72 x 2.0	180 (210)	140 (165)	110 (128)	120	95	75	55	75	172	235	1 1/4	15	480	100	80	100 ^{-0.1} _{-0.6}	80
200	140	110	90	M130 x 2.0	M100 x 2.0	M80 x 2.0	195 (225)	150 (175)	120 (140)	135	105	85	55	85	184	262	1 1/2	15	526	115	90	125 ^{-0.1} _{-0.6}	90
220	160	125	100	M150 x 2.0	M120 x 2.0	M95 x 2.0	225 (260)	180 (210)	140 (175)	155	120	95	60	89	184	292	1 1/2	15	550	125	100	125 ^{-0.1} _{-0.6}	100
250	180	140	110	M170 x 2.0	M130 x 2.0	M100 x 2.0	255 (295)	195 (225)	150 (175)	175	135	105	65	106	200	325	2	15	596	125	110	125 ^{-0.1} _{-0.6}	100

★1. Only long rod end thread type : the dimension "C" is the value in parentheses.

CB : Cap Detachable Clevis.....Nominal Pressure 7 · 14 MPa

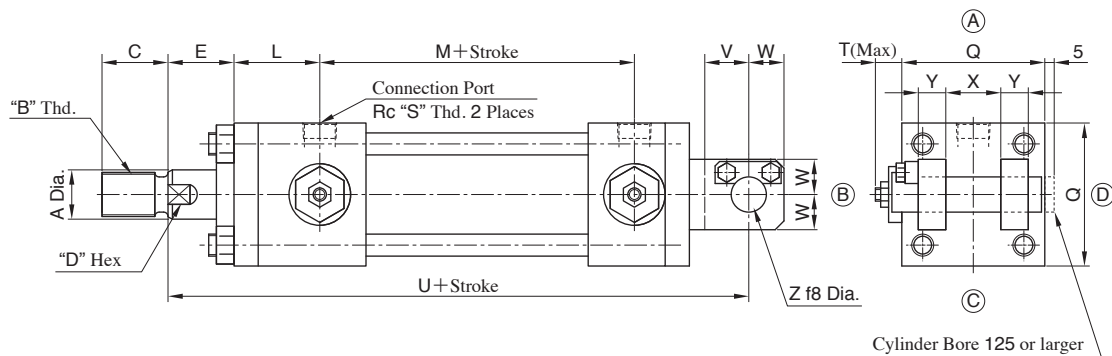

Option

With Dust Cover:

Refer to SD type page J-24 for dimensions of dust cover.

Cylinder Bore	A			B			C*1			D			E	L	M	Q	S	T	U	V	W	X	Y	Z
	Rod Size			Rod Size			Rod Size			Rod Size														
	"A"	"B"	"C"	"A"	"B"	"C"	"A"	"B"	"C"	"A"	"B"	"C"												
32	-	18	14	-	M16 x 1.5	M12 x 1.25	-	25 (32)	18 (24)	-	14	12	30	39	88	58	3/8	12	209	20	16	25 ^{+0.4} _{+0.1}	12.5	16
40	28	22	18	M24 x 1.5	M20 x 1.5	M16 x 1.5	35 (48)	30 (40)	25 (32)	24	19	14	30	39	88	65	3/8	12	209	20	16	25 ^{+0.4} _{+0.1}	12.5	16
50	36	28	22	M30 x 1.5	M24 x 1.5	M20 x 1.5	45 (60)	35 (48)	30 (40)	30	24	19	30	44	96	80	1/2	12	230	25	20	31.5 ^{+0.4} _{+0.1}	16	20
63	45	36	28	M39 x 1.5	M30 x 1.5	M24 x 1.5	60 (78)	45 (60)	35 (48)	41	30	24	35	42	104	94	1/2	12	261	40	30	40 ^{+0.4} _{+0.1}	20	31.5
80	56	45	36	M48 x 1.5	M39 x 1.5	M30 x 1.5	75 (96)	60 (78)	45 (60)	50	41	30	35	48	118	110	3/4	12	291	40	30	40 ^{+0.4} _{+0.1}	20	31.5
100	70	56	45	M64 x 2.0	M48 x 1.5	M39 x 1.5	95 (128)	75 (96)	60 (78)	65	50	41	40	54	120	138	3/4	12	316	50	40	50 ^{+0.4} _{+0.1}	25	40
125	90	70	56	M80 x 2.0	M64 x 2.0	M48 x 1.5	120 (140)	95 (128)	75 (96)	85	65	50	45	63	134	168	1	15	365	62	50	63 ^{+0.4} _{+0.1}	31.5	50
140	100	80	63	M95 x 2.0	M72 x 2.0	M56 x 2.0	140 (165)	110 (128)	80 (112)	95	75	55	50	65	142	188	1	15	400	79	65	80 ^{+0.6} _{+0.1}	40	63
150	106	85	67	M100 x 2.0	M76 x 2.0	M60 x 2.0	150 (175)	115 (128)	85 (120)	100	80	60	50	67	147	196	1	15	412	82	65	80 ^{+0.6} _{+0.1}	40	63
160	110	90	70	M100 x 2.0	M80 x 2.0	M64 x 2.0	150 (175)	120 (140)	95 (128)	105	85	65	55	66	158	215	1	15	445	89	75	80 ^{+0.6} _{+0.1}	40	71
180	125	100	80	M120 x 2.0	M95 x 2.0	M72 x 2.0	180 (210)	140 (165)	110 (128)	120	95	75	55	75	172	235	1 1/4	15	480	100	80	100 ^{+0.6} _{+0.1}	50	80
200	140	110	90	M130 x 2.0	M100 x 2.0	M80 x 2.0	195 (225)	150 (175)	120 (140)	135	105	85	55	85	184	262	1 1/2	15	526	115	90	125 ^{+0.6} _{+0.1}	63	90
220	160	125	100	M150 x 2.0	M120 x 2.0	M95 x 2.0	225 (260)	180 (210)	140 (175)	155	120	95	60	89	184	292	1 1/2	15	550	125	100	125 ^{+0.6} _{+0.1}	63	100
250	180	140	110	M170 x 2.0	M130 x 2.0	M100 x 2.0	255 (295)	195 (225)	150 (175)	175	135	105	65	106	200	325	2	15	596	125	110	125 ^{+0.6} _{+0.1}	63	100

★1. Only long rod end thread type : the dimension "C" is the value in parentheses.

TA : Rod Trunnion.....Nominal Pressure 7 · 14 MPa

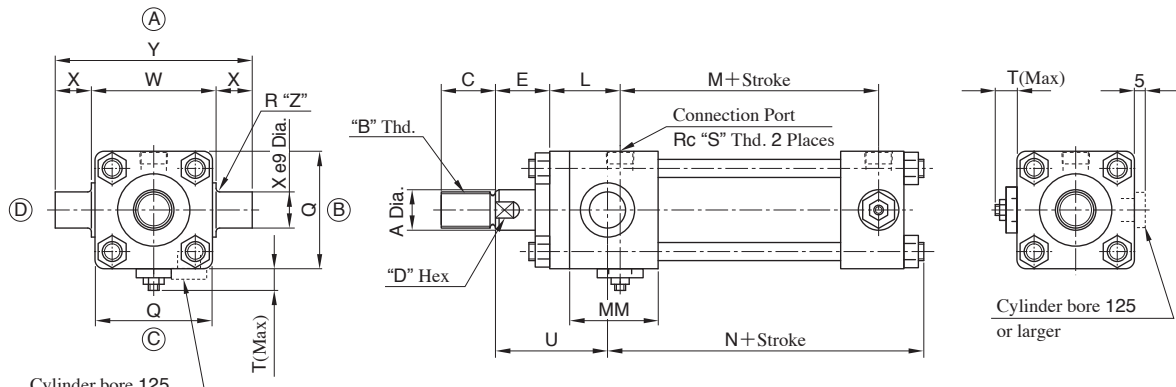

Positions of port at the rod side, cushion adjusting valve and air vent valve are only available below.

- Port position: (A)
- Cushion adjusting valve position: (C)
- Air vent valve position: (C)

Please specify the positions (A),(B),(C),(D) at cap cover side only.

Options

Double Rod Type "N"

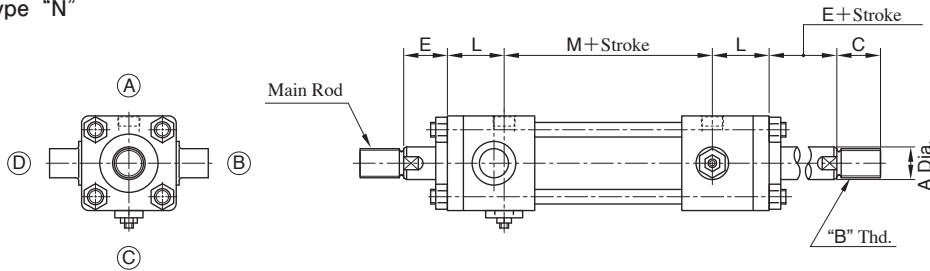

With Dust Cover:

Refer to SD type page J-24 for dimensions of dust cover.

Cylinder Bore	A		B			C★1			D			E	L	M	N	Q	S	T	U	W	X	Y	Z	MM	
	Rod Size		Rod Size			Rod Size			Rod Size																
	"A"	"B"	"C"	"A"	"B"	"C"	"A"	"B"	"C"	"A"	"B"														"C"
32	-	18	14	-	M16 x 1.5	M12 x 1.25	-	25 (32)	18 (24)	-	14	12	30	39	88	118	58	3/8	12	62	58 ⁰ _{-0.3}	20	98	2	49
40	28	22	18	M24 x 1.5	M20 x 1.5	M16 x 1.5	35 (48)	30 (40)	25 (32)	24	19	14	30	39	88	120	65	3/8	12	62	69 ⁰ _{-0.3}	20	109	2	49
50	36	28	22	M30 x 1.5	M24 x 1.5	M20 x 1.5	45 (60)	35 (48)	30 (40)	30	24	19	30	44	96	132	80	1/2	12	66	85 ⁰ _{-0.35}	25	135	2.5	56
63	45	36	28	M39 x 1.5	M30 x 1.5	M24 x 1.5	60 (78)	45 (60)	35 (48)	41	30	24	35	42	104	138	94	1/2	12	74	98 ⁰ _{-0.35}	31.5	161	2.5	44
80	56	45	36	M48 x 1.5	M39 x 1.5	M30 x 1.5	75 (96)	60 (78)	45 (60)	50	41	30	35	48	118	153	110	3/4	12	82	118 ⁰ _{-0.35}	31.5	181	2.5	50
100	70	56	45	M64 x 2.0	M48 x 1.5	M39 x 1.5	95 (128)	75 (96)	60 (78)	65	50	41	40	54	120	162	138	3/4	12	89	145 ⁰ _{-0.4}	40	225	3	57
125	90	70	56	M80 x 2.0	M64 x 2.0	M48 x 1.5	120 (140)	95 (128)	75 (96)	85	65	50	45	63	134	185	168	1	15	103	175 ⁰ _{-0.4}	50	275	3	67
140	100	80	63	M95 x 2.0	M72 x 2.0	M56 x 2.0	140 (165)	110 (128)	80 (112)	95	75	55	50	65	142	193	188	1	15	112	195 ⁰ _{-0.46}	63	321	4	74
150	106	85	67	M100 x 2.0	M76 x 2.0	M60 x 2.0	150 (175)	115 (128)	85 (120)	100	80	60	50	67	147	203	196	1	15	112	206 ⁰ _{-0.46}	63	332	4	74
160	110	90	70	M100 x 2.0	M80 x 2.0	M64 x 2.0	150 (175)	120 (140)	95 (128)	105	85	65	55	66	158	210	215	1	15	126	218 ⁰ _{-0.46}	71	360	4	81

★1. Only long rod end thread type : the dimension "C" is the value in parentheses.

TC : Intermediate Trunnion.....Nominal Pressure 7 · 14 MPa

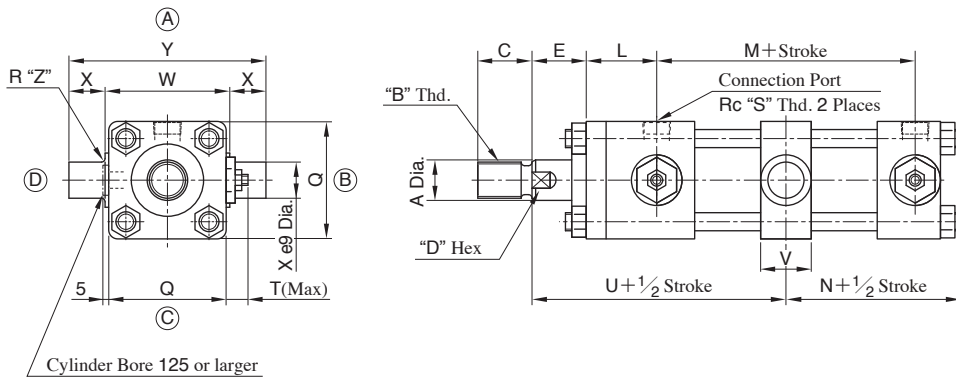

Options

Double Rod Type "N"

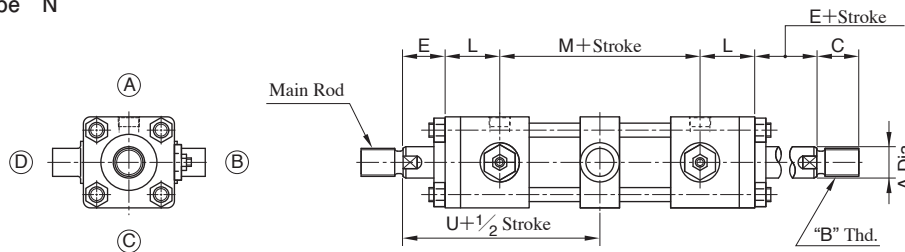

With Dust Cover:

Refer to SD type page J-24 for dimensions of dust cover.

Cylinder Bore	A			B			C*1			D			E	L	M	N	Q	S	T	U	V	W	X	Y	Z
	Rod Size			Rod Size			Rod Size			Rod Size															
	"A"	"B"	"C"	"A"	"B"	"C"	"A"	"B"	"C"	"A"	"B"	"C"													
32	-	18	14	-	M16 x 1.5	M12 x 1.25	-	25 (32)	18 (24)	-	14	12	30	39	88	67	58	3/8	12	113	30	58 ⁰ _{-0.3}	20	98	2
40	28	22	18	M24 x 1.5	M20 x 1.5	M16 x 1.5	35 (48)	30 (32)	25 (32)	24	19	14	30	39	88	69	65	3/8	12	113	30	69 ⁰ _{-0.3}	20	109	2
50	36	28	22	M30 x 1.5	M24 x 1.5	M20 x 1.5	45 (60)	35 (48)	30 (40)	30	24	19	30	44	96	77	80	1/2	12	121	38	85 ⁰ _{-0.35}	25	135	2.5
63	45	36	28	M39 x 1.5	M30 x 1.5	M24 x 1.5	60 (78)	45 (60)	35 (48)	41	30	24	35	42	104	80	94	1/2	12	132	45	98 ⁰ _{-0.35}	31.5	161	2.5
80	56	45	36	M48 x 1.5	M39 x 1.5	M30 x 1.5	75 (96)	60 (78)	45 (60)	50	41	30	35	48	118	89	110	3/4	12	146	45	118 ⁰ _{-0.35}	31.5	181	2.5
100	70	56	45	M64 x 2.0	M48 x 1.5	M39 x 1.5	95 (128)	75 (96)	60 (78)	65	50	41	40	54	120	95	138	3/4	12	156	57	145 ⁰ _{-0.4}	40	225	3
125	90	70	56	M80 x 2.0	M64 x 2.0	M48 x 1.5	120 (140)	95 (128)	75 (96)	85	65	50	45	63	134	111	168	1	15	177	58	175 ⁰ _{-0.4}	50	275	3
140	100	80	63	M95 x 2.0	M72 x 2.0	M56 x 2.0	140 (165)	110 (128)	80 (112)	95	75	55	50	65	142	117	188	1	15	188	78	195 ⁰ _{-0.46}	63	321	4
150	106	85	67	M100 x 2.0	M76 x 2.0	M60 x 2.0	150 (175)	115 (128)	85 (120)	100	80	60	50	67	147	121	196	1	15	194	78	206 ⁰ _{-0.46}	63	332	4
160	110	90	70	M100 x 2.0	M80 x 2.0	M64 x 2.0	150 (175)	120 (140)	95 (128)	105	85	65	55	66	158	129	215	1	15	207	88	218 ⁰ _{-0.46}	71	360	4
180	125	100	80	M120 x 2.0	M95 x 2.0	M72 x 2.0	180 (210)	140 (165)	110 (128)	120	95	75	55	75	172	141	235	1 1/4	15	216	98	243 ⁰ _{-0.46}	80	403	4
200	140	110	90	M130 x 2.0	M100 x 2.0	M80 x 2.0	195 (225)	150 (175)	120 (140)	135	105	85	55	85	184	153	262	1 1/2	15	232	108	272 ⁰ _{-0.52}	90	452	5
220	160	125	100	M150 x 2.0	M120 x 2.0	M95 x 2.0	225 (260)	180 (210)	140 (175)	155	120	95	60	89	184	158	292	1 1/2	15	241	117	300 ⁰ _{-0.52}	100	500	5
250	180	140	110	M170 x 2.0	M130 x 2.0	M100 x 2.0	255 (295)	195 (225)	150 (175)	175	135	105	65	106	200	177	325	2	15	271	117	335 ⁰ _{-0.57}	100	535	5

*1. Only long rod end thread type : the dimension "C" is the value in parentheses.

Options

Rod End Attachment

T-End (Rod End Eye): Option Code "L"

Y-End (Rod End Clevis): Option Code "M"

Approx. Mass kg

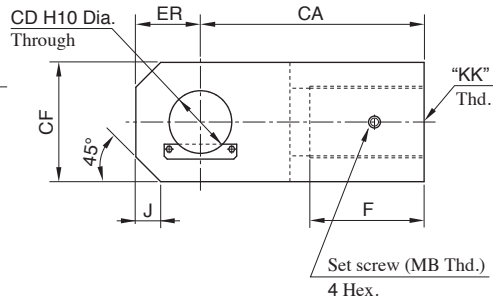
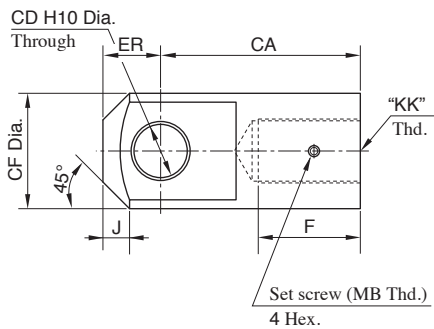
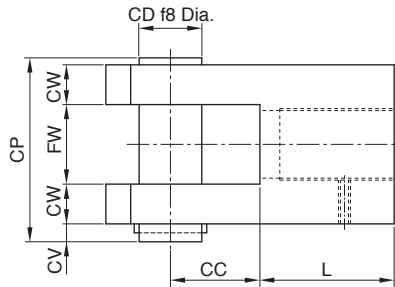
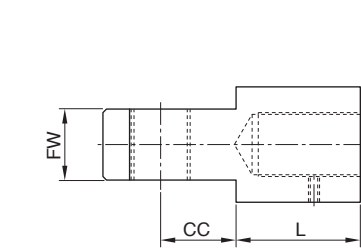

Cylinder Bore	Rod End Attachment	
	T-End (L)	Y-End (M)
32	B	0.5
	C	0.6
40	B	0.4
	C	0.6
50	B	0.9
	C	1.1
63	B	2.4
	C	3.5
80	B	2.1
	C	3.4
100	B	4.2
	C	7.5
125	B	8.4
	C	14.8
140	B	19.0
	C	28.5
150	B	16.8
	C	27.1
160	B	22.4
	C	34.5

Option Code "L"

Cylinder Bore	Rod Size	KK	F	CA	CC	CD	CF	ER	FW	J	L
32	B M16x1.5	34	60	23	16	39	20	25 ^{-0.1} _{-0.4}	8	37	
	C M12x1.25	27									
40	B M20x1.5	39	60	23	16	39	20	25 ^{-0.1} _{-0.4}	8	37	
	C M16x1.5	34									
50	B M24x1.5	44	70	28	20	49	25	31.5 ^{-0.1} _{-0.4}	10	42	
	C M20x1.5	39									
63	B M30x1.5	50	115	43	31.5	62	35	40 ^{-0.1} _{-0.4}	15	72	
	C M24x1.5	44									
80	B M39x1.5	65	115	43	31.5	62	35	40 ^{-0.1} _{-0.4}	15	72	
	C M30x1.5	50									
100	B M48x1.5	80	145	55	40	79	40	50 ^{-0.1} _{-0.4}	20	90	
	C M39x1.5	65									
125	B M64x2.0	100	180	65	50	100	50	63 ^{-0.1} _{-0.4}	25	115	
	C M48x1.5	80									
140	B M72x2.0	115	225	85	63	130	65	80 ^{-0.1} _{-0.6}	30	140	
	C M56x2.0	85									
150	B M76x2.0	120	225	85	63	130	65	80 ^{-0.1} _{-0.6}	30	140	
	C M60x2.0	90									
160	B M80x2.0	125	240	90	71	140	70	80 ^{-0.1} _{-0.6}	35	150	
	C M64x2.0	100									

Option Code "M"

Cylinder Bore	Rod Size	KK	F	CA	CC	CD	CF	ER	CW	FW	CV	CP	J	L
32	B M16x1.5	33	60	27	16	32	16	12.5	25 ^{+0.4} _{+0.1}	12	68	4	33	
	C M12x1.25	33												
40	B M20x1.5	33	60	27	16	32	16	12.5	25 ^{+0.4} _{+0.1}	12	68	4	33	
	C M16x1.5	33												
50	B M24x1.5	38	70	32	20	40	20	16	31.5 ^{+0.4} _{+0.1}	12	80	10	38	
	C M20x1.5	38												
63	B M30x1.5	50	115	50	31.5	60	30	20	40 ^{+0.4} _{+0.1}	12	98	12	65	
	C M24x1.5	40												
80	B M39x1.5	65	115	50	31.5	60	30	20	40 ^{+0.4} _{+0.1}	12	98	12	65	
	C M30x1.5	50												
100	B M48x1.5	85	145	60	40	80	40	25	50 ^{+0.4} _{+0.1}	18	125	15	85	
	C M39x1.5	65												
125	B M64x2.0	100	180	70	50	100	50	31.5	63 ^{+0.4} _{+0.1}	18	150	20	110	
	C M48x1.5	80												
140	B M72x2.0	115	225	90	63	120	65	40	80 ^{+0.6} _{+0.1}	18	185	25	135	
	C M56x2.0	85												
150	B M76x2.0	120	225	90	63	120	65	40	80 ^{+0.6} _{+0.1}	18	185	25	135	
	C M60x2.0	90												
160	B M80x2.0	125	240	100	71	140	70	40	80 ^{+0.6} _{+0.1}	18	185	30	140	
	C M64x2.0	100												

★ Please consult us separately for cylinder bore 180 or larger. (special design products)

Options

Lock Nut : Option Code "K"

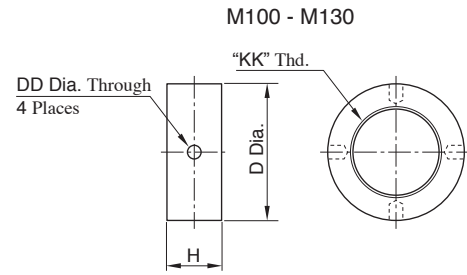
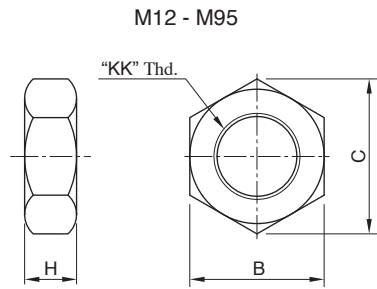

KK	H	B	C	Approx.Mass kg	KK	H	B	C	Approx.Mass kg
M12×1.25	7	19	21.9	0.02	M56×2	30	80	92.4	0.77
M16×1.5	10	22	25.4	0.02	M60×2	33	85	98.1	0.94
M20×1.5	12	27	31.2	0.03	M64×2	35	90	104	1.10
M24×1.5	14	32	37	0.05	M72×2	38	100	115	1.44
M30×1.5	17	41	47.3	0.11	M76×2	40	105	121	1.65
M39×1.5	20	55	63.5	0.24	M80×2	43	110	127	1.93
M48×1.5	26	70	80.8	0.52	M95×2	47	130	150	2.90

KK	H	D	DD	Z	Approx.Mass kg
M100×2	60	150	15	18	4.9
M120×2	72	180	15	18	8.9
M130×2	78	200	20	25	11.9

List for Seals

CJT₁₄₀⁷⁰ - *32 - 50

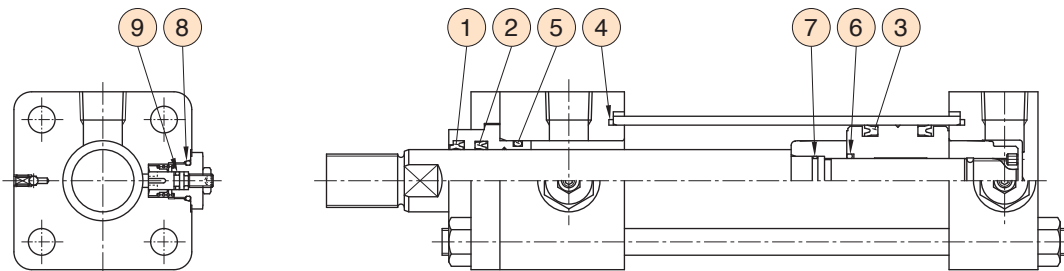

Cylinder Bore Rod Size	Model Numbers for Seal Kit	Item	Name								
			①	②	③	④ ^{★3}	⑤	⑥	⑦ ^{★4}	⑧	⑨
			Dust Seal	Rod Packing	Piston Packing	Packing for Cover	O-Ring for Bush	O-Ring for Piston (OR NBR-90 P(G) * *-N)	O-Ring for Cushion Ring	O-Ring for Plug	O-Ring for Slide Rod (OR NBR-70-1 P5-N)
32	B	KS-CJT32B-20	SDR-18	SKY-18	SKY-24	GR-32	P21	P12	S12	P14	P5
	C	KS-CJT32C-20	SDR-14	SKY-14							
	40	A	KS-CJT40A-20	SDR-28	SKY-28	SKY-30	GR-40	G30	P16	S16	P14
B		KS-CJT40B-20	SDR-22	SKY-22	G25						
C		KS-CJT40C-20	SDR-18	SKY-18							
50	A	KS-CJT50A-20	SDR-36	SKY-36	SKY-40	GR-50	G40	P20	S20	P14	P5
	B	KS-CJT50B-20	SDR-28	SKY-28			G30				
	C	KS-CJT50C-20	SDR-22	SKY-22							

★1. Please specify the seal kit numbers above when ordering the seals.

★2. Material of standard packings is Nitrile-Rubber. Please select Fluoro-Rubber packing material if Phosphate Esters oil is used. Please specify "F-" in addition to the model of seal kit after "KS".

★3. Packing code "GR" of item No.4 is square O-ring.

★4. O-ring code "S" of item No.7 is special O-ring.

Note : The packing code changes without notice.

List of Seals

CJT₁₄₀⁷⁰ - * 63 - 250

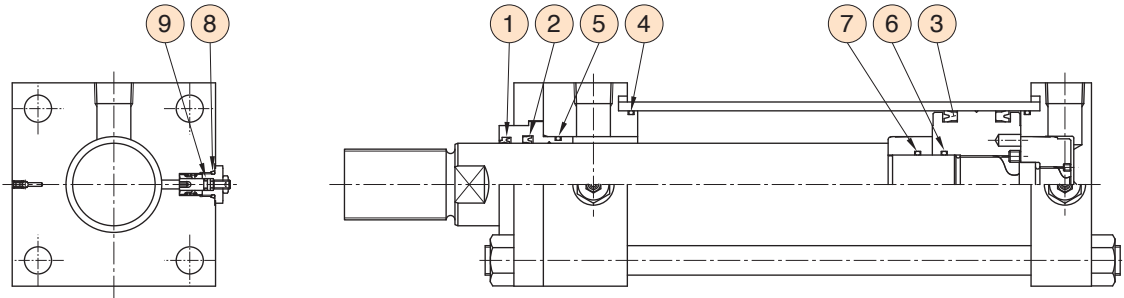

Cylinder Bore	Rod Size	Model Numbers for Seal Kit	Q'ty	Item									
				Name									
				①	②	③	④	⑤	⑥	⑦	⑧	⑨	
				Dust Seal	Rod Packing	Piston Packing	Packing for Cover	O-Ring for Bush	O-Ring for Piston	O-Ring for Cushion Ring	O-Ring for Plug	O-Ring for Slide Rod (OR NBR-70-1) P**-N	
				1	1	2	2	1	1	1	★3	★3	
63	A	KS-CJT 63A-20		SDR- 45	SKY- 45A	SKY- 53	G 55	G 50	G25	-	P14	P5	
	B	KS-CJT 63B-20		SDR- 36	SKY- 36			G 40		G25			
	C	KS-CJT 63C-20		SDR- 28	SKY- 28			G 60		P31			
80	A	KS-CJT 80A-20		SDR- 56	SKY- 56	SKY- 71	G 75	G 60	P31	-	P14	P5	
	B	KS-CJT 80B-20		SDR- 45	SKY- 45A			G 50		P31			
	C	KS-CJT 80C-20		SDR- 36	SKY- 36			G 75		G50			
100	A	KS-CJT100A-20		SDR- 70	SKY- 70	SKY- 85	G 95	G 75	G40	-	P14	P5	
	B	KS-CJT100B-20		SDR- 56	SKY- 56			G 60		G40			
	C	KS-CJT100C-20		SDR- 45	SKY- 45A			G 95		G40			
125	A	KS-CJT125A-20		SDR- 90	SKY- 90	SKY-112A	G120	G 95	G50	G50	P18, P14	P7, P5	
	B	KS-CJT125B-20		SDR- 70	SKY- 70			G 75		G50	P18	P7	
	C	KS-CJT125C-20		SDR- 56	SKY- 56			G 110		G50	-	P18, P14	P7, P5
140	A	KS-CJT140A-20		SDR-100	SKY-100	SKY-125	G135	G 110	G50	-	P18	P7	
	B	KS-CJT140B-20		SDR- 80	SKY- 80			G 85		G50			
	C	KS-CJT140C-20		SDR- 63	SKY- 63			G 115		G55			-
150	A	KS-CJT150A-20		SDR-106	SKY-106	SKY-136	G145	G 115	G55	-	P18	P7	
	B	KS-CJT150B-20		SDR- 85	SKY- 85			G 90		G55			
	C	KS-CJT150C-20		SDR- 67	SKY- 67			G 125		G60			-
160	A	KS-CJT160A-20		SDR-110	SKY-110	SKY-145	G150	G 125	G60	-	P18	P7	
	B	KS-CJT160B-20		SDR- 90	SKY- 90			G 95		G60			
	C	KS-CJT160C-20		SDR- 70	SKY- 70			G 140		G70			-
180	A	KS-CJT180A-20		SDR-125	SKY-125	SKY-165	G170	G 140	G70	-	P18	P7	
	B	KS-CJT180B-20		SDR-100	SKY-100			G 110		G70			
	C	KS-CJT180C-20		SDR- 80	SKY- 80			G 155		G75			-
200	A	KS-CJT200A-20		SDR-140	SKY-140	SKY-180	G190	G 155	G75	-	P18	P7	
	B	KS-CJT200B-20		SDR-110	SKY-110			G 125		G75			
	C	KS-CJT200C-20		SDR- 90	SKY- 90			G 175		G85			-
220	A	KS-CJT220A-20		SDR-160	SKY-160	SKY-200	G210	G 175	G85	-	P18	P7	
	B	KS-CJT220B-20		SDR-125	SKY-125			G 140		G85			
	C	KS-CJT220C-20		SDR-100	SKY-100			G 195		G95			-
250	A	KS-CJT250A-20		SDR-180	SKY-180	SKY-230	G240	G 195	G95	-	P18	P7	
	B	KS-CJT250B-20		SDR-140	SKY-140			G 155		G95			
	C	KS-CJT250C-20		SDR-110	SKY-110								

★1. Please specify the seal kit numbers above when ordering the seals.
 ★2. Material of standard packings is Nitrile-Rubber. Please select Fluoro-Rubber packing material if Phosphate Esters oil is used. Please specify "F-" in addition to the model of seal kit after "KS".
 ★3. There are 2 O-Rings.
 The large O-Rings (1 each) / Cap Side, The small O-Rings (1 each) / Rod Side.
 Note : The packing code changes without notice.