

Pressure Reducing and Relieving Valves

Pressure reducing and relieving valves are composite pressure control valves having pressure reducing and counterbalancing functions developed for hydraulic balancing circuits.

Specifications

Model Numbers	Max. Operating Pres. MPa	Pres. Adj. Range MPa	Max. Flow L/min	Relieving Flow L/min	Drain Flow L/min	Approx. Mass kg
RBG-03- *-10	14	0.6 - 13.5	50	50	0.6 - 1	4.2
RBG-06- *-10	25	0.8 - 24.5	125	125	1.5 - 2	11

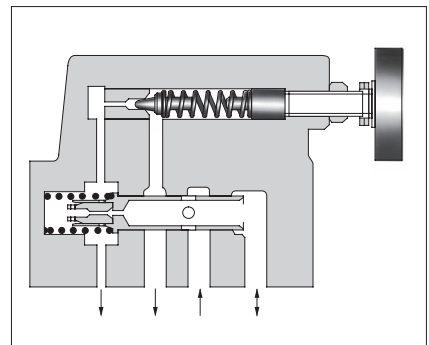
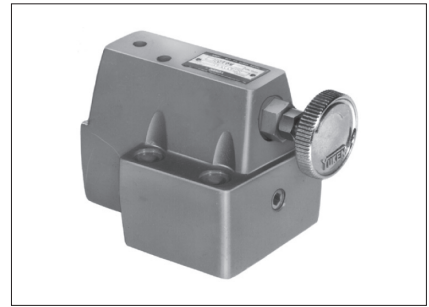

Model Number Designation

RB	G	-03	-R	-10
Series Number	Type of Mounting	Valve Size	Drain Type	Design Number
RB : Pressure Reducing and Relieving Valves	G : Sub-plate Mounting	03 06	None: Internal Drain R : External Drain	10

Graphic Symbols

Internal Drain

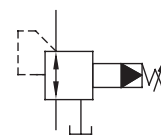

External Drain

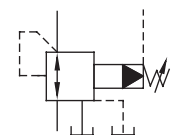
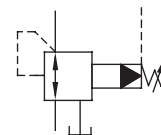
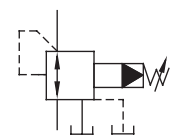

Vent Connection

Instructions

- To use remote control relief valve in the venting circuit, see page C-3. If the internal volume of the vent line is too large, chattering is likely to occur. Thus, as far as possible reduce the inside diameter and the length of the pipe.
- To adjust the pressure, loosen the lock nut and turn the pressure adjustment handle slowly clockwise for higher pressures and anti-clockwise for lower pressures. After adjustments, do not forget to tighten the lock nut.
- Connect the tank pipe not to any other line but directly to the reservoir.

Sub-plates

Valve Model Numbers	Sub-plate Model Numbers	Thread Size Rc	Approx. Mass kg
RBG-03	RBGM-03-10	3/8	1.6
	RBGM-03X-10	1/2	
RBG-06	RBGM-06-10	3/4	4.8
	RBGM-06X-10	1	

- Sub-plates are available. Specify the sub-plate model number from the table above. When sub-plates are not used, the mounting surface should have a good machined finish. (1/16")

Accessories

Mounting Bolts

Valve Model Numbers	Socket Head Cap Screw
RBG-03	M10×65L 4 pcs.
RBG-06	M10×70L 4 pcs.

RBG-03

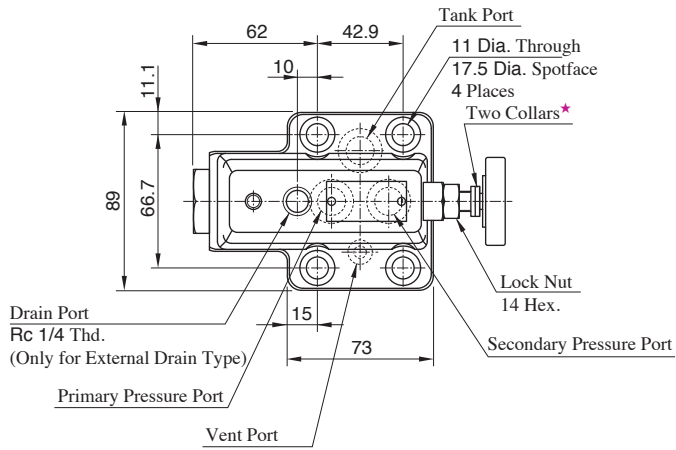

★ Pressure is limited by collars fitted. If a working pressure cannot be attained, remove some collars. One collar is equivalent to 10 MPa.

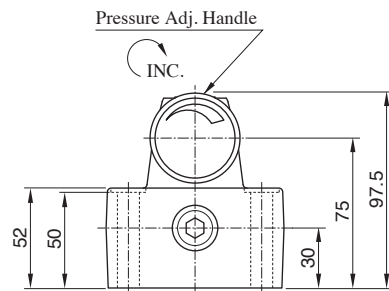
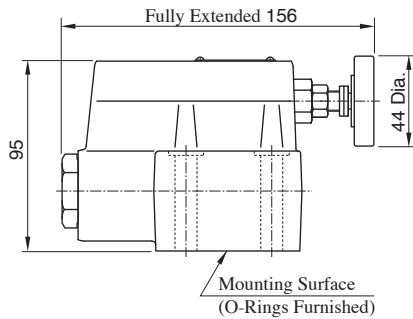

RBG-06

★ Pressure is limited by collars fitted. If a working pressure cannot be attained, remove some collars. One collar is equivalent to 10 MPa.

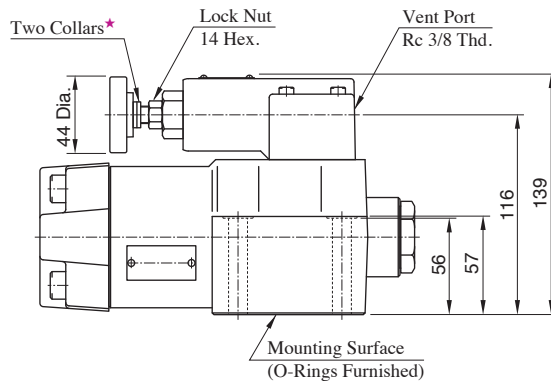
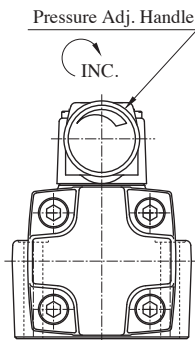
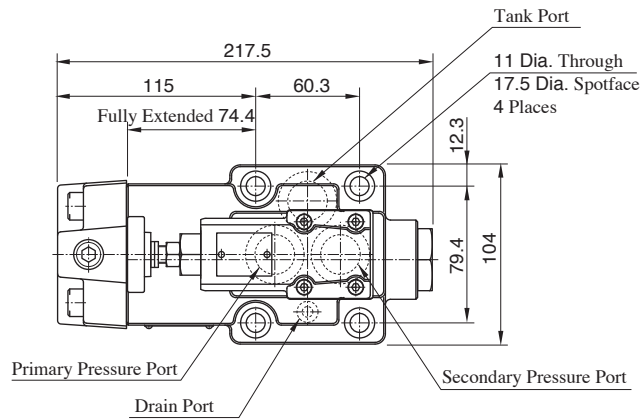

Sub-plate

RBGM-03 *

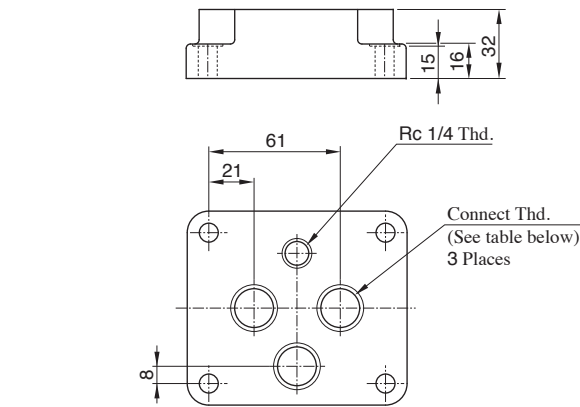
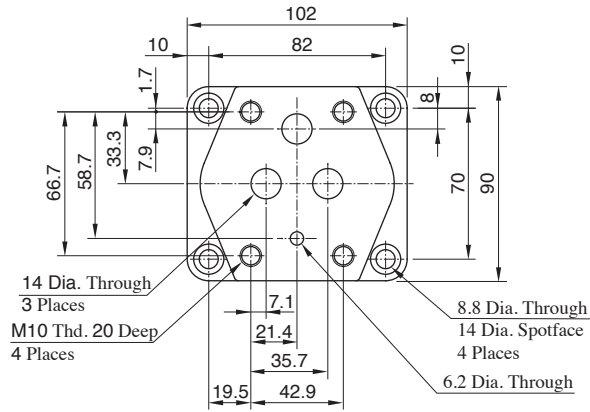

Sub-plate Model Numbers	Thread Size Rc
RBGM-03-10	3/8
RBGM-03X-10	1/2

RBGM-06 *

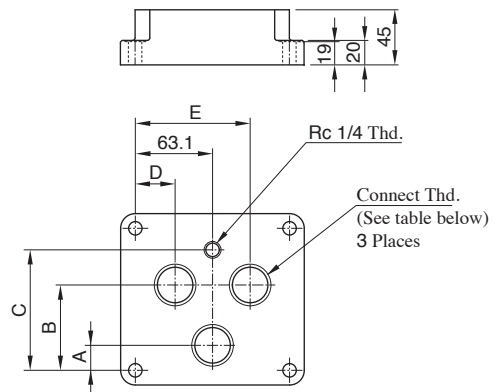
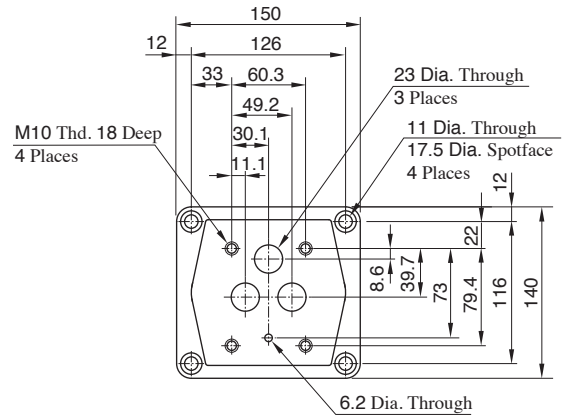

Sub-plate Model Numbers	Thread Size Rc	A	B	C	D	E
RBGM-06-10	3/4	20.7	65.7	95	37.1	89.1
RBGM-06X-10	1	20.4	69.7	98.4	32.5	93.8

Nominal Override Characteristics

Hydraulic Fluid: Viscosity 35 mm²/s
Specific Gravity 0.850

--- Relieving
— Reducing

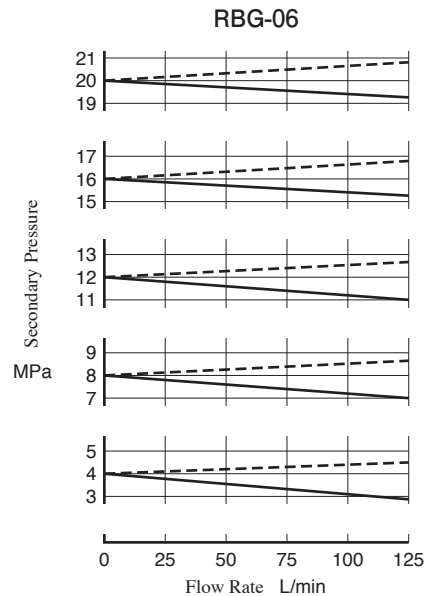
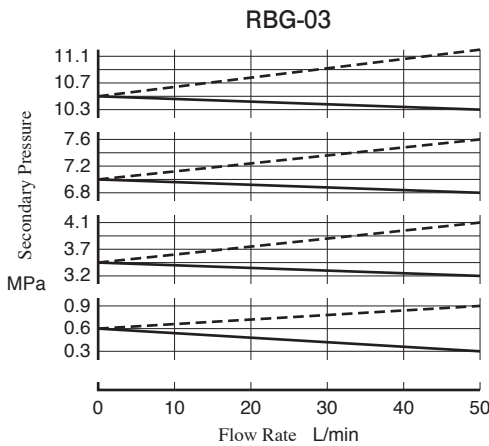

Min. Adj. Pressure & Vent Pressure

Hydraulic Fluid: Viscosity 35 mm²/s
Specific Gravity 0.850

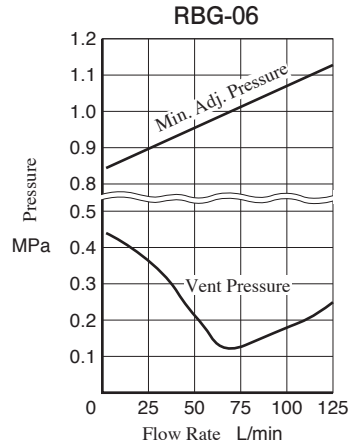
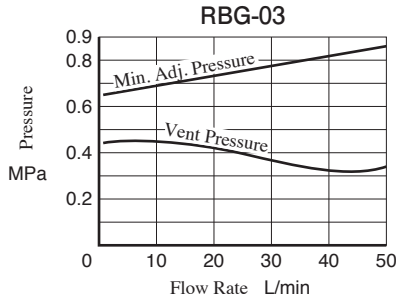

Pressure Drop

Hydraulic Fluid: Viscosity 35 mm²/s
Specific Gravity 0.850

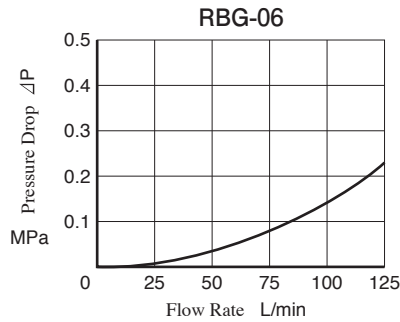
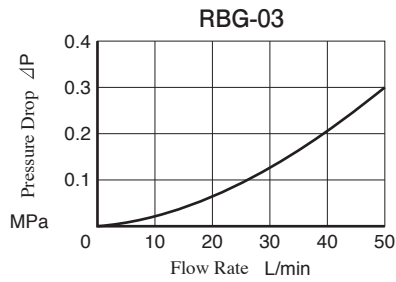

- For any other viscosity, multiply the factors in the table right.
- For any other specific gravity (G'), the pressure drop (P') may be obtained from the formula below.
 $\Delta P' = \Delta P (G'/0.850)$

Viscosity mm ² /s	15	20	30	40	50	60	70	80	90	100
Factor	0.81	0.87	0.96	1.03	1.09	1.14	1.19	1.23	1.27	1.30

List of Seals

RBG-03

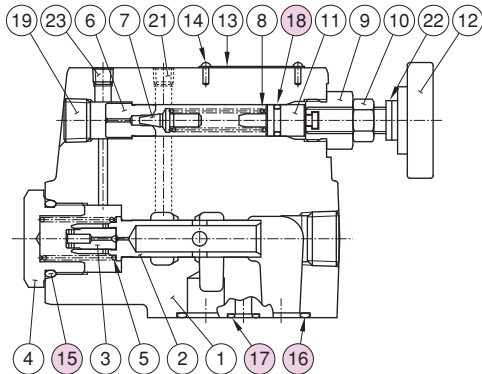

Item	Name of Parts	Part Numbers	Qty.
15	O-Ring	OR NBR-90 P24-N	1
16	O-Ring	OR NBR-90 P18-N	3
17	O-Ring	OR NBR-90 P9-N	1
18	O-Ring	OR NBR-70-1 P9-N	1

RBG-06

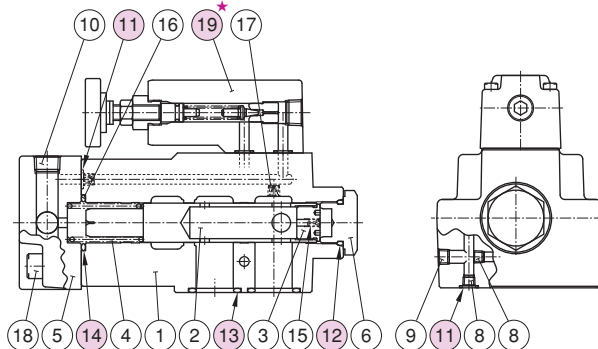

Item	Name of Parts	Part Numbers	Qty.
11	O-Ring	OR NBR-90 P9-N	2
12	O-Ring	OR NBR-90 P24-N	1
13	O-Ring	OR NBR-90 P28-N	3
14	O-Ring	OR NBR-90 P30-N	1

★ For details of pilot relief valves item ⑱, see page C-4, DG-01.