

## Frequency Response

<Conditions>

● Hydraulic Circuit: Port A/B Closed ● Supply Pressure : 14 MPa

### ● LSVG-03-4/10/20/40-10

Amplifier : AMLS-A-D48- \* -10 (Power Supply: 48 V DC)

Input Signal  $\pm 25\%$

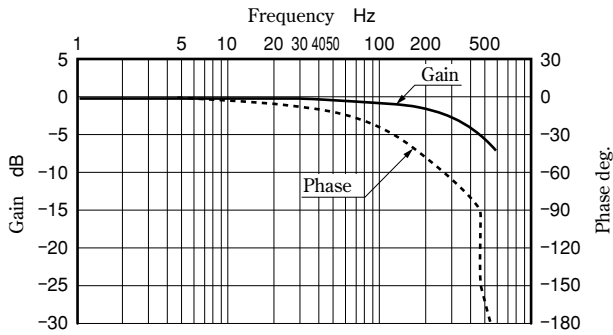

Input Signal  $\pm 100\%$

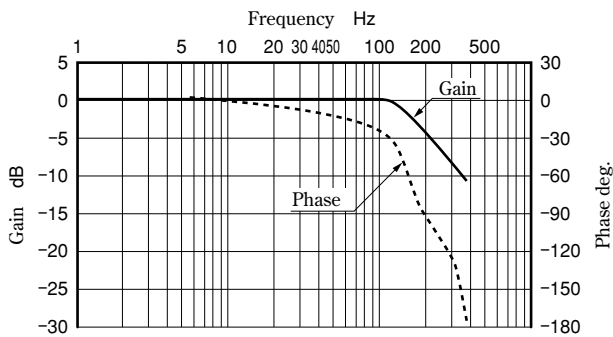

Amplifier : AMLS-A-D24- \* -10 (Power Supply: 24 V DC)

Input Signal  $\pm 25\%$

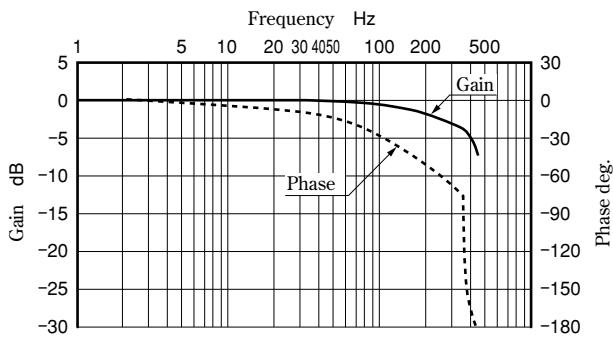

Input Signal  $\pm 100\%$

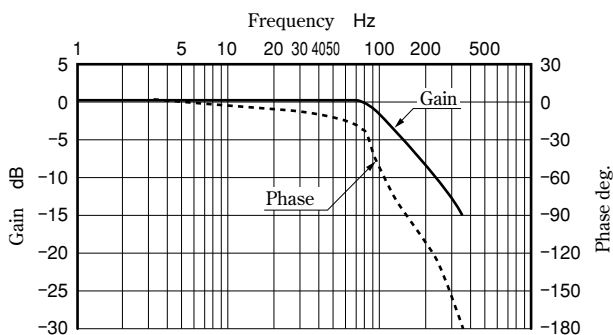

### ● LSVG-03-60-10

Amplifier : AMLS-B-D48- \* -10 (Power Supply: 48 V DC)

Input Signal  $\pm 25\%$

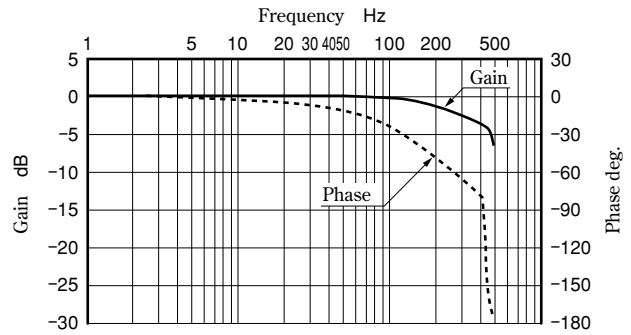

Input Signal  $\pm 100\%$

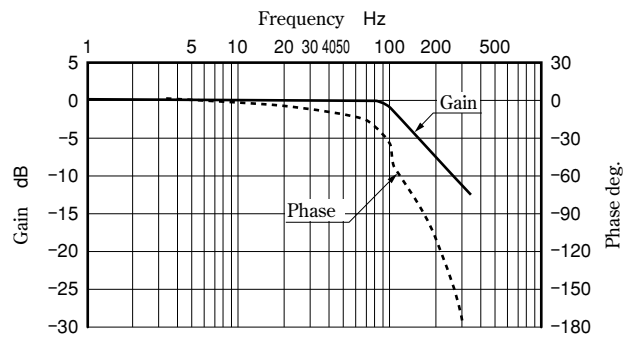

Amplifier : AMLS-B-D24- \* -10 (Power Supply: 24 V DC)

Input Signal  $\pm 25\%$

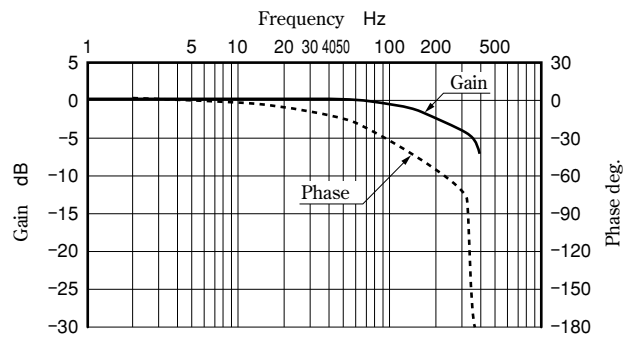

Input Signal  $\pm 100\%$

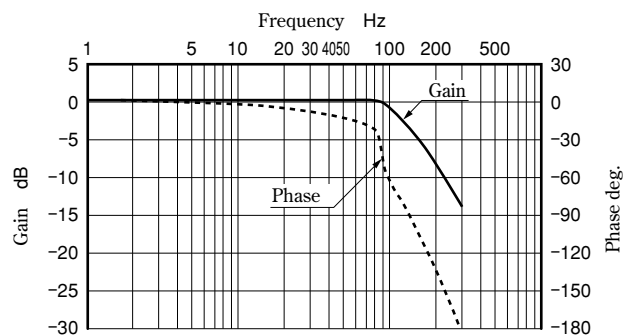

# Tow Stage Type High-Speed Linear Servo Valves

Two stage type linear servo valves are a type of high-flow servo valve that has a direct type high speed linear servo valve in its pilot stage to drive the main spool. These valves control the positions of the pilot and main spools with electrical feedback, achieving high accuracy and response.

- High flow**  
 The valves consist of two stages to provide a high flow rate (Rated flow at  $\Delta P = 7 \text{ MPa}$ : 750 - 3800 L/min).
- High accuracy**  
 The valves have a low hysteresis of 0.1 % or less, achieving high accuracy. They allow the main unit to operate with much higher repeatability.
- High response characteristics**  
 The valves provide significantly high levels of step and frequency responses, which are typically used as measures of response characteristics; the step response is 8 ms ( $0 \leftrightarrow 100 \%$ ), and the frequency response is 105 Hz/ $-90^\circ$  ( $\pm 25 \%$  amplitude) (Representative values for LSVHG-06-900). Thus, the valves ensure the achievement of unprecedented high response.
- Excellent contamination resistance**  
 As is the case with the direct type linear servo valves, the permissible level of fluid contamination for these valves is up to NAS 1638 class 10.

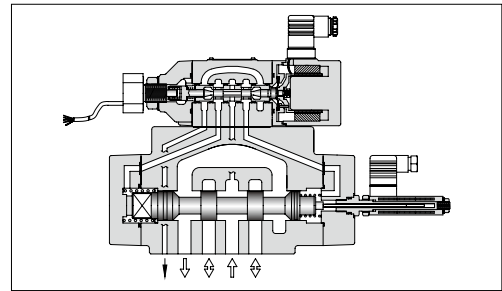
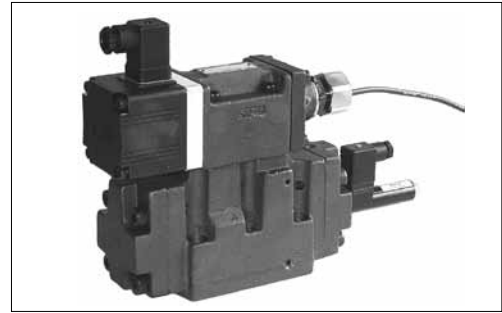

Graphic Symbols

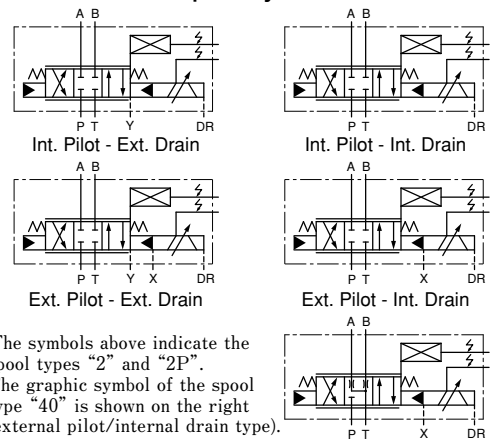

## Model Number Designation

F—	LSVHG	—06	—900	—2P	—E	T	—R	—A	—10
Fluid Type	Series Number	Valve Size	Rated Flow @ $\Delta P = 7 \text{ MPa}$	Spool Type	Pilot Connection	Drain Connection	Cable Departure Direction	Fail-safe Function	Design Number
F : Special Seals for Phosphate Ester Type Fluid (Omit if not required)	LSVHG : Two Stage Type High Speed Linear Servo Valves	04	750 : 750 L/min	2 : 10% Overlap 	None : Internal Pilot  E : External Pilot	None : External Drain  T : Internal Drain	(Viewed from the linear motor side) None : Upper (Standard) R : Right L : Left	None : P→B→A→T Position Valve Opening: Full  A : P→A→B→T Position Valve Opening: Full	10
		06	900 : 900 L/min 1300 : 1300 L/min	40 : Open Centre A, B & T 					20
		10	3800 : 3800 L/min	2P : Zero Lap  (Dual Flow Gain)					

## Exclusive Amplifiers

To ensure stable performance, it is recommended to use Yuken's AMLS series linear servo amplifiers.

Valve Model Number	Amplifier Model
LSVHG-04-750	AMLS-C2-D * - * -10
LSVHG-06-900	AMLS-C-D * - * -10
LSVHG-06-1300 LSVHG-10-3800	AMLS-D-D * - * -10

## Attachment

Model Number	Mounting Bolt	Qty.	Bolt Tightening Torque
LSVHG-04	Hex. Soc. Head Cap Screw:M 6 ×55L	2	12.9 - 15.9 Nm
	Hex. Soc. Head Cap Screw:M10×60L	4	60.6 - 74.1 Nm
LSVHG-06	Hex. Soc. Head Cap Screw:M12×85L	6	104 - 127 Nm
LSVHG-10	Hex. Soc. Head Cap Screw:M20×90L	6	494 - 603 Nm

## Characteristics of LSVHG-06-1300 (Fluid Viscosity: 30 mm<sup>2</sup>/s)

### No-Load Flow Characteristics

<Conditions> ● Valve Pressure Difference: 1 MPa (Pressure Difference per Land : 0.5 MPa)

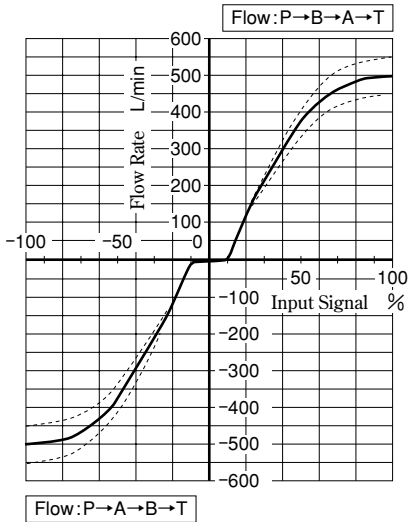

Around Null Position Input Signal -20 ⇔ +20 %

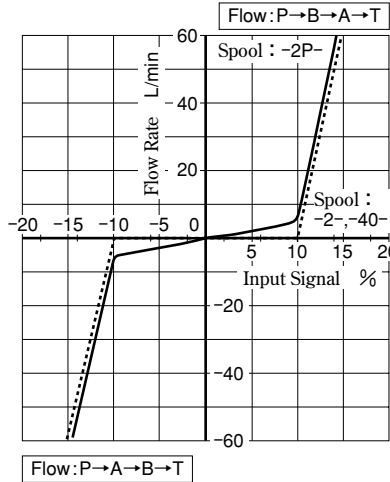

### Load Flow Characteristics

<Conditions>

● Input Signal : 100 %

Note) Tolerance for Load Flow : ±10 %

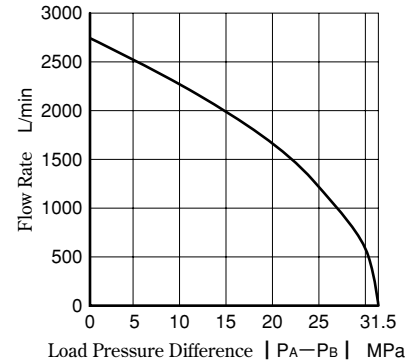

### Step Response

<Conditions> ● Input Signal : 0 ⇔ 100 % ● Supply/Pilot Pressure : 14 MPa

Amplifier : AMLS-D-D48 \* -10 (Power Supply: 48 V DC)

Amplifier : AMLS-D-D24 \* -10 (Power Supply: 24 V DC)

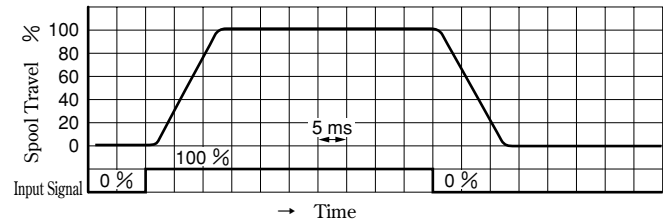
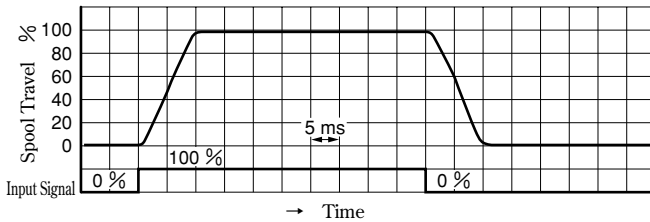

### Frequency Response

<Conditions> ● Hydraulic Circuit: Port A/B Closed ● Supply/Pilot Pressure : 14 MPa

Amplifier : AMLS-D-D48 \* -10 (Power Supply: 48 V DC)

Amplifier : AMLS-D-D24 \* -10 (Power Supply: 24 V DC)

