

03 Series Modular Valves

Type of Modular Valve

Class	Name and Model Numbers	Graphic Symbols	Page	Class	Name and Model Numbers	Graphic Symbols	Page
Solenoid Operated Directional Valves	(S-) DSG-03-***-50 E-DSG-03-***-D*-50 T-DSG-03-***-D24*-50 G-DSG-03-***-51		★	Flow Control Valves	Temperature Compensated Throttle and Check Valves (for "A&B-Lines", Meter-out) MSTW-03-X-20		F-58
	Pressure Control Valves	Relief Valves (for "P-Line") MBP-03-**-70			F-48	Throttle Valves (for "P-Line") MSP-03-30	
Relief Valves (for "A-Line") MBA-03-**-70			F-48	Check and Throttle Valves (for "P-Line") MSCP-03-20		F-61	
Relief Valves (for "B-Line") MBB-03-**-70			F-48	Throttle and Check Valves (for "A-Line", Meter-out) MSA-03-X-70		F-62	
Relief Valves (for "A&B-Lines") MBW-03-**-70			F-48	Throttle and Check Valves (for "A-Line", Meter-in) MSA-03-Y-70		F-62	
Reducing Valves (for "P-Line") MRP-03-**-70			F-50	Throttle and Check Valves (for "B-Line", Meter-out) MSB-03-X-70		F-62	
Reducing Valves (for "A-Line") MRA-03-**-70			F-50	Throttle and Check Valves (for "B-Line", Meter-in) MSB-03-Y-70		F-62	
Reducing Valves (for "B-Line") MRB-03-**-70			F-50	Throttle and Check Valves (for "A&B-Lines", Meter-out) MSW-03-X-70		F-62	
Reducing Valves for Low Pressure Setting (for "P-Line") MRLP-03-10			F-52	Throttle and Check Valves (for "A&B-Lines", Meter-in) MSW-03-Y-70		F-62	
Reducing Valves for Low Pressure Setting (for "A-Line") MRLA-03-10			F-52	Directional Control Valves	Check Valves (for "P-Line") MCP-03-**-70		F-64
Reducing Valves for Low Pressure Setting (for "B-Line") MRLB-03-10			F-52		Check Valves (for "A-Line") MCA-03-**-70		F-64
Sequence Valves (for "P-Line") MHP-03-**-20			F-54		Check Valves (for "B-Line") MCB-03-**-70		F-64
Counterbalance Valves (for "A-Line") MHA-03-**-20			F-54		Check Valves (for "T-Line") MCT-03-**-70		F-64
Counterbalance Valves (for "B-Line") MHB-03-**-20			F-54		Check Valves (for "A&B-Lines") MCW-03-**-70		F-64
Flow Control Valves (for "P-Line") MFP-03-11			F-56		Check Valves (for "P&T-Lines") MCPT-03-P*-T*-10		F-66
Flow Control and Check Valves (for "A-Line", Meter-in) MFA-03-X-11			F-56		Anti-Cavitation Valves MAC-03-10		F-67
Flow Control and Check Valves (for "A-Line", Meter-in) MFA-03-Y-11			F-56		Pilot Operated Check Valves (for "A-Line") MPA-03-**-70		F-68
Flow Control and Check Valves (for "B-Line", Meter-out) MFB-03-X-11			F-56		Pilot Operated Check Valves (for "B-Line") MPB-03-**-70		F-68
Flow Control and Check Valves (for "B-Line", Meter-in) MFB-03-Y-11			F-56		Pilot Operated Check Valves (for "A&B-Lines") MPW-03-**-70		F-68
Flow Control and Check Valves (for "A&B-Lines", Meter-out) MFW-03-X-11		F-56	Modular Plates and Mounting Bolts		End Plates (Blocking Plates) MDC-03-A-10		F-70
Flow Control and Check Valves (for "A&B-Lines", Meter-in) MFW-03-Y-11		F-56			End Plates (Bypass Plates) MDC-03-B-10		F-70
Temperature Compensated Throttle and Check Valves (for "A-Line", Meter-out) MSTA-03-X-20		F-58		Connecting Plates MDS-03-10		F-70	
Temperature Compensated Throttle and Check Valves (for "B-Line", Meter-out) MSTB-03-X-20		F-58		Base Plates MMC-03-T-**-21		F-71	
				Bolt Kits MBK-03-**-10		F-73	

★ Refer to the relevant pages of catalog "E: DIRECTIONAL CONTROLS"

Relief Modular Valves

Specifications

Model Numbers	Max. Operating Pressure MPa	Max. Flow L/min
MB *-03 *-70	35	120

Model Number Designation

MBA	-03	-B	-70
Series Number	Valve Size	Pres. Adj. Range MPa	Design Number
MBP: Relief Valve for P-Line MBA: Relief Valve for A-Line MBB: Relief Valve for B-Line MBW: Relief Valve for A&B-Lines	03	B: ★-7 C: 3.5-14 K: 7-35	70

★See the "Min. Adjustment Pressure" of this page.

Instructions

The minimum adjustment pressure equals the value obtained from the minimum adjustment pressure characteristics plus the tank line back pressure of this page. This back pressure should include the value of the T-line pressure drop characteristics of the valves stacked to the base plate side of the modular valve. To make pressure adjustment, loosen the lock nut and turn the pressure adjustment screw clockwise or anti-clockwise. For an increase of pressure, turn the screw clockwise. Be sure to re-tighten the lock nut firmly after making adjustment to the pressure.

In case of a small flow, the setting pressure may become unstable. To avoid this, refer to the minimum flow characteristic curve of the this page and use the valve within a range as shown with .

Typical Performance Characteristics

Hydraulic Fluid: Viscosity 35 mm²/s, Specific Gravity 0.850

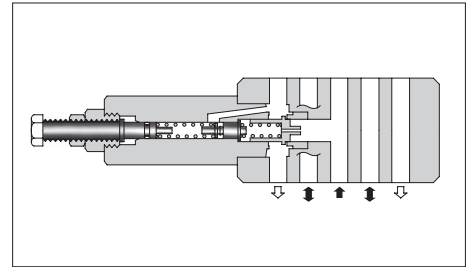
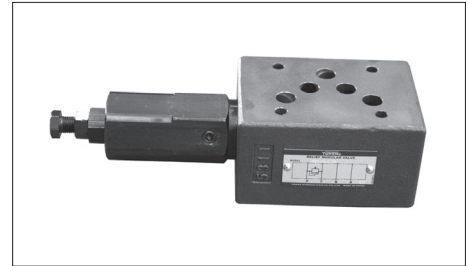
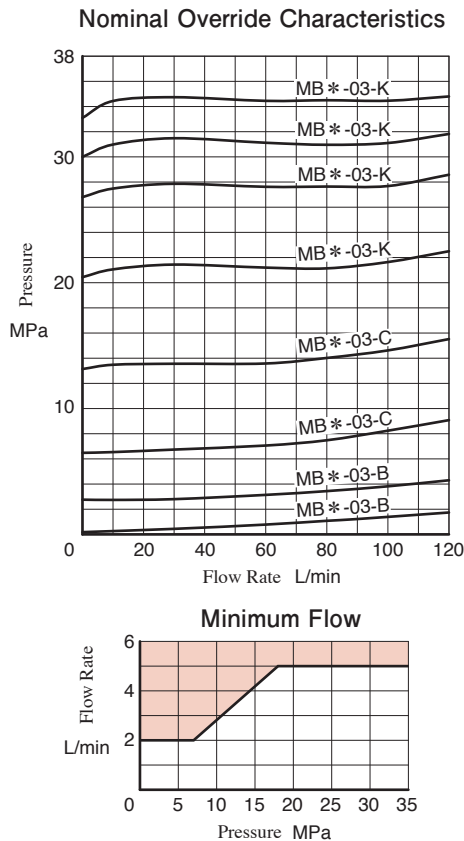

Model Numbers	Graphic Symbols	Graphic Symbols
MBP-03		
MBA-03		
MBB-03		
MBW-03		

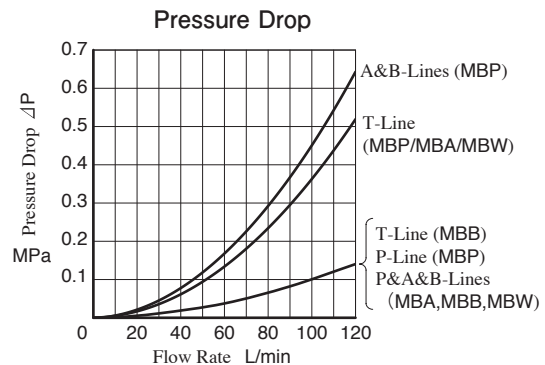
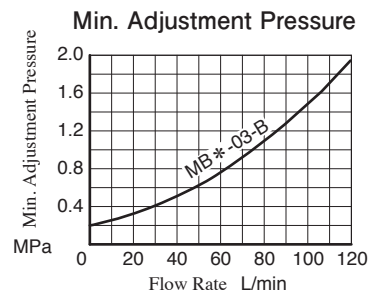

MBW-03

Approx. Mass.....4.0kg

MBP-03, MBA-03

MBP FullyExtended 209
MBA FullyExtended 207

Approx. Mass.....3.4 kg

For other dimensions, refer to (MBW-03) in the drawing left.

MBB-03

FullyExtended 207

Approx. Mass.....3.4 kg

For other dimensions, refer to (MBW-03) in the drawing left.

List of Seals

MBP-03
MBA-03
MBB-03
MBW-03

MBP-03
MBA-03

- MBP-03: The pressure adjustment part is assembled on the right side.
- MBW-03: The pressure adjustment part is assembled on the both sides.

Item	Name of Parts	Part Numbers	Qty.			
			MBP-03	MBA-03	MBB-03	MBW-03
1	O-Ring	AS568-014 (NBR-90)	5	5	5	5
2	O-Ring	OR NBR-70-1 P6-N	1	1	1	2
3	O-Ring	OR NBR-90 P16-N	1	1	1	2
4	O-Ring	OR NBR-90 P26-N	1	1	1	2

Reducing Modular Valves

Specifications

Model Numbers	Max. Operating Pressure MPa	Max. Flow L/min
MR*-03-A-70*	35	80
MR*-03-B/C/H-70		120

*If the pressure is set below 1.2 MPa, the maximum flow is limited. See the "Min. Adjustment Pressure vs. Max. Flow" of this page.

Model Number Designation

MRP	-03	-B	-70
Series Number	Valve Size	Pres. Adj. Range MPa	Design Number
MRP: Reducing Valve for P-Line MRA: Reducing Valve for A-Line MRB: Reducing Valve for B-Line	03	A: ★-3.5 B: 1-7 C: 3.5-14 H: 7-31.5	70

*See the "Min. Adjustment Pressure vs. Max. Flow" of this page.

Instructions

The minimum adjustment pressure equals the value obtained from the minimum adjustment pressure characteristics plus the tank line back pressure of this page. This back pressure should include the value of the T-line pressure drop characteristics of the valves stacked to the base plate side of the modular valve. To make pressure adjustment, loosen the lock nut and turn the pressure adjustment screw clockwise or anticlockwise. For an increase of pressure, turn the screw clockwise. Be sure to re-tighten the lock nut firmly after making adjustment to the pressure.

Typical Performance Characteristics

Hydraulic Fluid: Viscosity 35 mm²/s, Specific Gravity 0.850

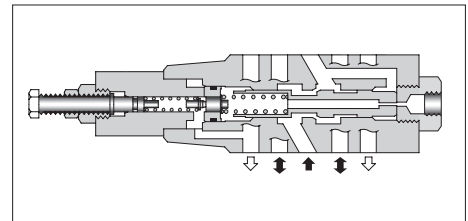
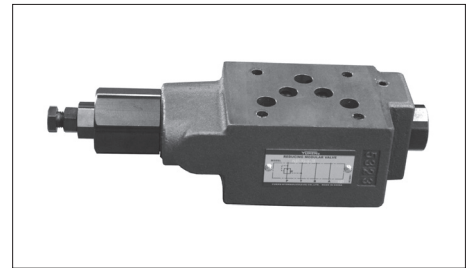

Model Numbers	Graphic Symbols	Graphic Symbols
MRP-03		
MRA-03		
MRB-03		

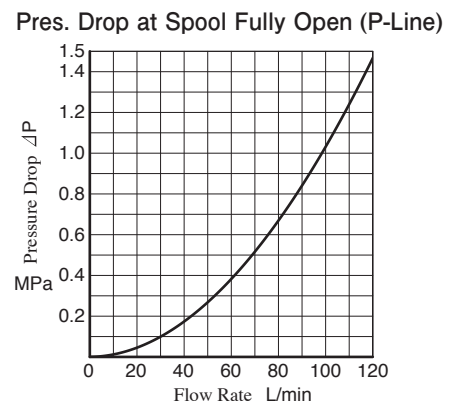
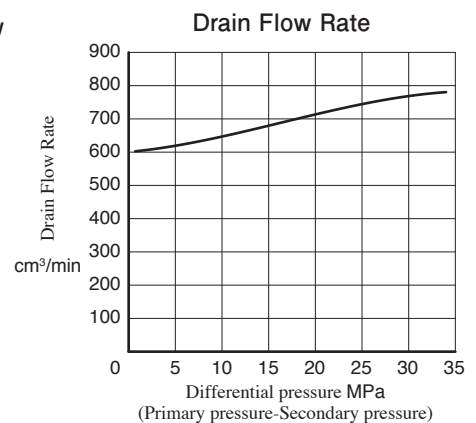
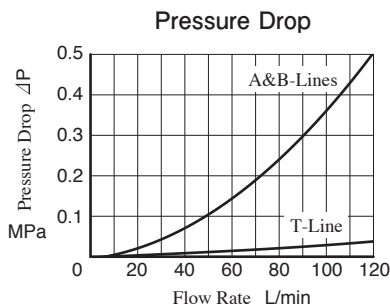
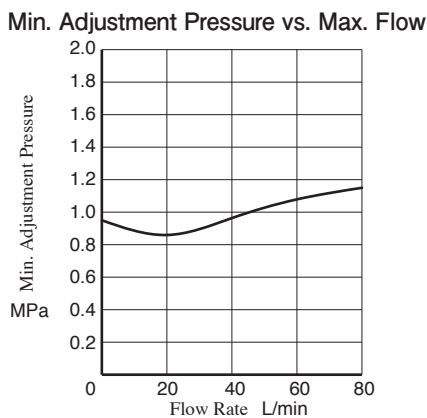
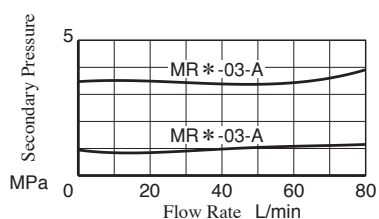
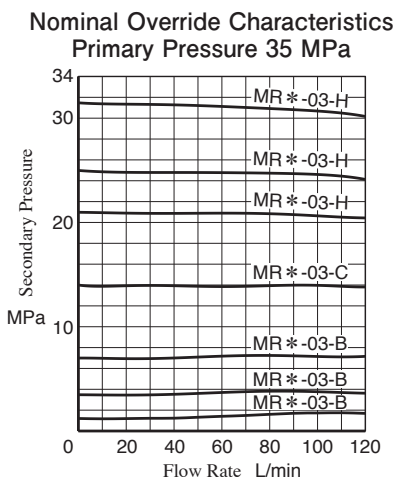

MRP-03
MRB-03

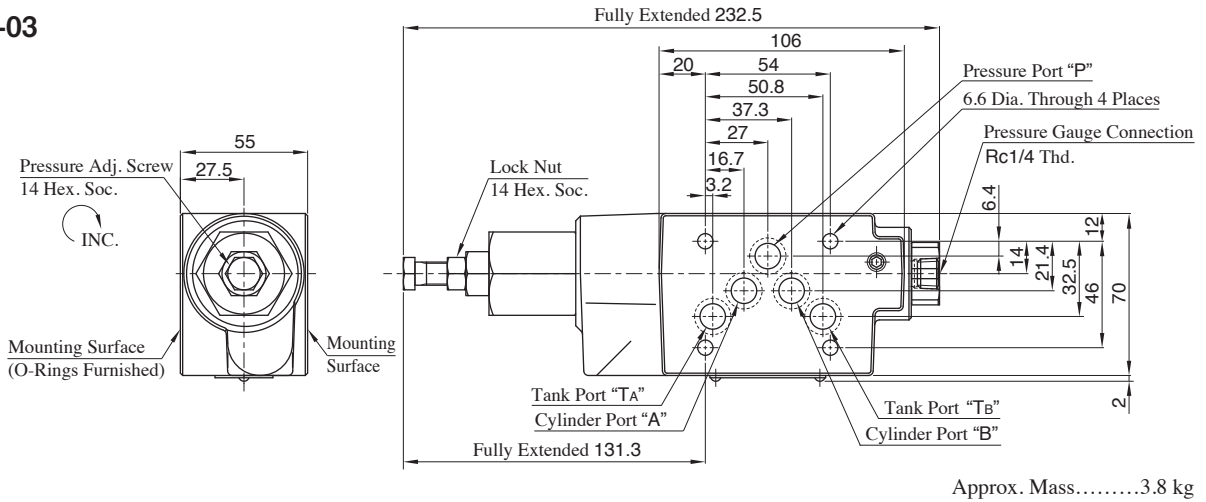

MRA-03

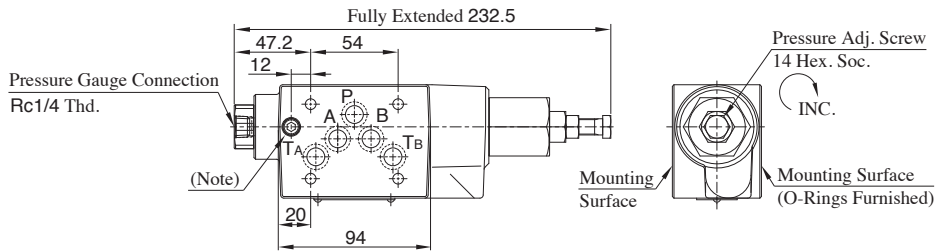

Note: If mounting surface dimension equipped with the valves based on ISO 4401-05-05-0-05, pilot port of stacking valves will interfere with bolt hole of MRA-03, so check gasket surface of the stacking valves.

List of Seals

MRP-03
MRA-03
MRB-03

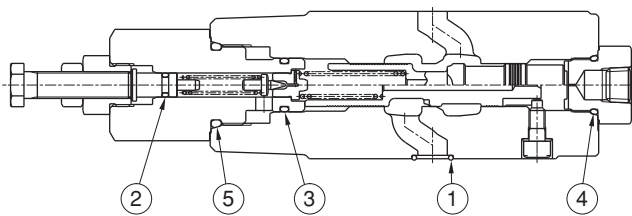

MRP-03

Item	Name of Parts	Part Numbers	Qty.
1	O-Ring	AS568-014 (NBR-90)	5
2	O-Ring	OR NBR-70-1 P6-N	1
3	O-Ring	OR NBR-90 P16-N	1
4	O-Ring	OR NBR-90 P18-N	1
5	O-Ring	OR NBR-90 P26-N	1

- MRA-03: The pressure adjustment part is assembled on the right side.
- MRB-03: The pressure adjustment part is assembled on the left side.

Reducing Modular Valves for Low Pressure Setting

Specifications

Model Numbers	Max. Operating Pressure MPa	Pres. Adj. Range MPa	Max.Flow L/min
MRL*-03-10	7	0.2-6.5	50*

★ If the pressure is set below 0.8 MPa, the maximum flow is limited. See the "Min. Adjustment Pressure vs. Max. Flow" of this page and during use, stay within the shaded zone on the graph.

Model Number Designation

MRLP	-03	-10
Series Number	Valve Size	Design Number
MRLP:Low Pressure Setting Type Reducing Valve for P-Line	03	10
MRLA:Low Pressure Setting Type Reducing Valve for A-Line		
MRLB:Low Pressure Setting Type Reducing Valve for B-Line		

Instructions

If there is a pressure in drain line, it is added to the secondary setting pressure. Hence, drain line must be connected to tank directly with a low back pressure close to atmospheric pressure.

Typical Performance Characteristics

Hydraulic Fluid: Viscosity 35 mm²/s, Specific Gravity 0.850

Pres. Drop at Spool Fully Open (P-Line)

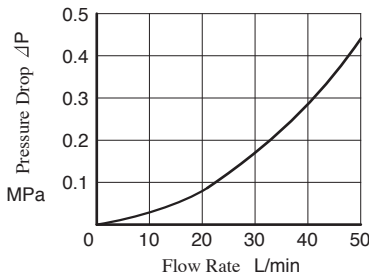

Pressure Drop

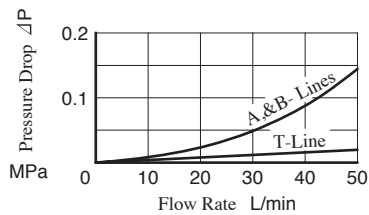

Min. Adjustment Pressure vs. Max. Flow

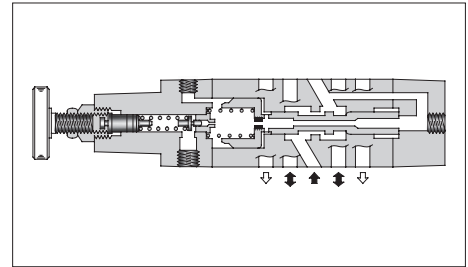
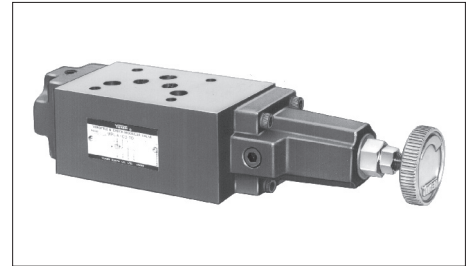
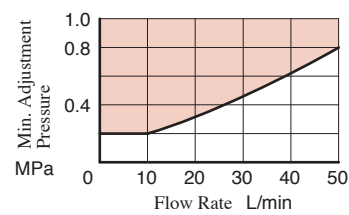

Model Numbers	Graphic Symbols	Graphic Symbols
MRLP-03		
MRLA-03		
MRLB-03		

**MRLP-03
MRLB-03**

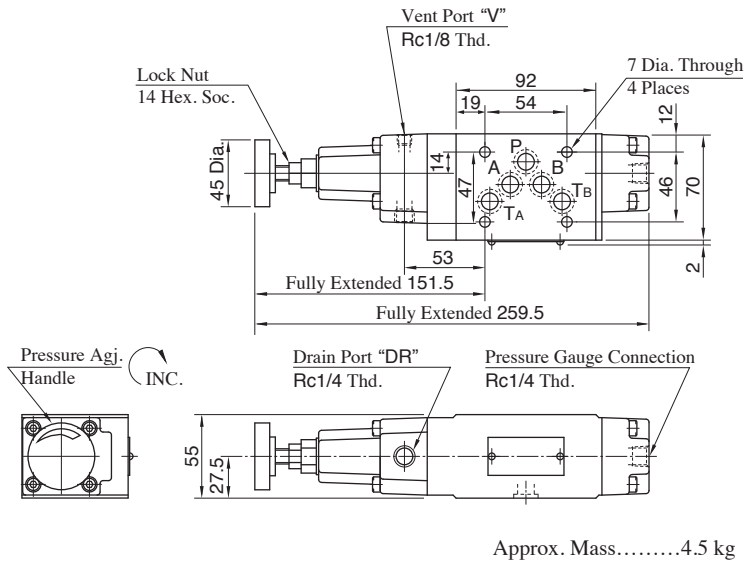

MRLA-03

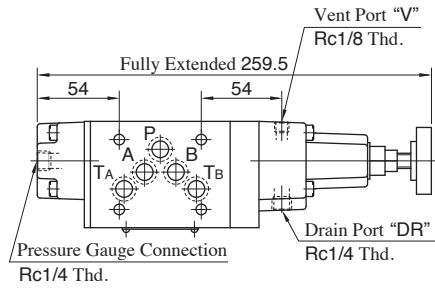

Approx. Mass.....4.5 kg

For other dimensions, refer to "MRLP-03/MRLB-03" in the drawing left.

List of Seals

**MRLP-03
MRLA-03
MRLB-03**

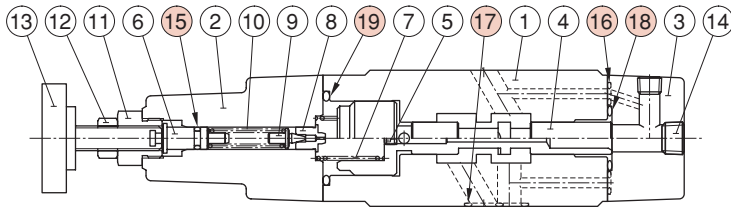

MRLP-03

- MRLA-03: The pressure adjustment part is assembled on the right side.
- MRLB-03: The cover will be rotated 180 degrees with respect to MRLP.

Item	Name of Parts	Part Numbers	Qty.
15	O-Ring	OR NBR-70-1 P6-N	1
16	O-Ring	OR NBR-90 P6-N	2
17	O-Ring	AS568-014 (NBR-90)	5
18	O-Ring	OR NBR-90 P22-N	1
19	O-Ring	OR NBR-90 P32-N	1

Sequence Modular Valves / Counterbalance Modular

Specifications

Model Numbers	Max. Operating Pressure MPa	Max. Flow L/min	Free Flow L/min
MHP-03- *-20	25	50	—
MH*-03- *-20			70

Model Number Designation

MHP	-03	-C	-20
Series Number	Valve Size	Pres. Adj. Range MPa	Design Number
MHP: Sequence Valve for P-Line	03	N: ★-1.8 A: 1.8-3.5 B: 3.5-7 C: 7-14	20
MHA: Counterbalance Valve for A-Line MHB: Counterbalance Valve for B-Line			20

★See the "Min. Adjustment Pressure vs. Max. Flow" of this page.

Instructions

The minimum adjustment pressure equals the value obtained from the minimum adjustment pressure characteristics plus the tank line back pressure of this page. This back pressure should include the value of the T-line pressure drop characteristics of the valves stacked to the base plate side of the modular valve.

To make pressure adjustment, loosen the lock nut and turn the pressure adjustment screw clockwise or anti-clockwise. For an increase of pressure, turn the screw clockwise. Be sure to re-tighten the lock nut firmly after making adjustment to the pressure.

Typical Performance Characteristics

Hydraulic Fluid: Viscosity 35 mm²/s, Specific Gravity 0.850

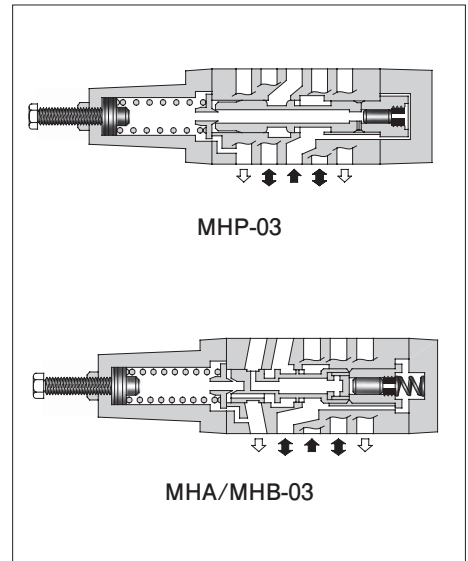
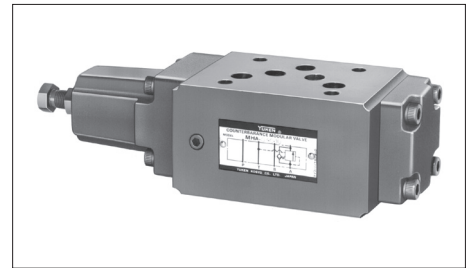
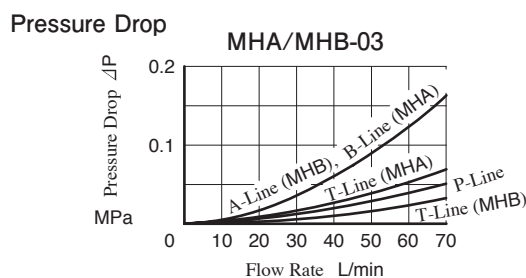
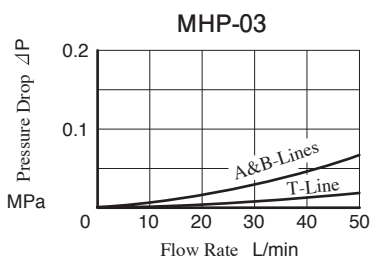
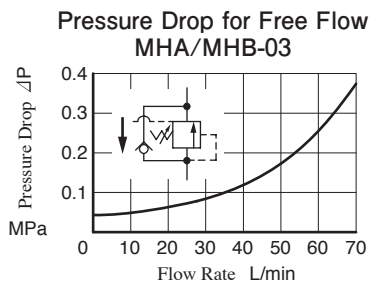
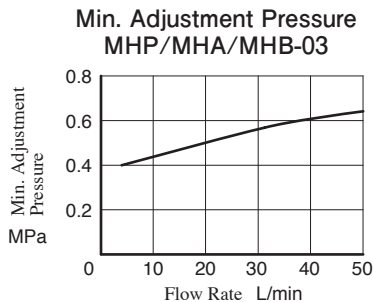

Model Numbers	Graphic Symbols	Graphic Symbols
MHP-03		
MHA-03		
MHB-03		

MHP-03

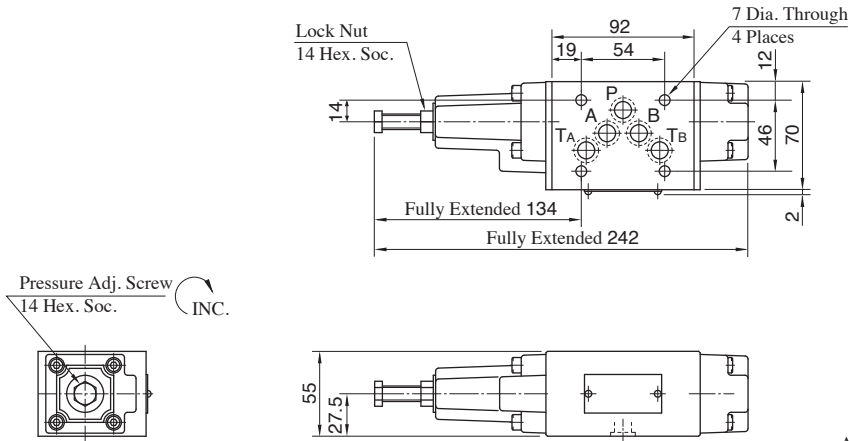

Approx. Mass.....3.5 kg

MHA-03

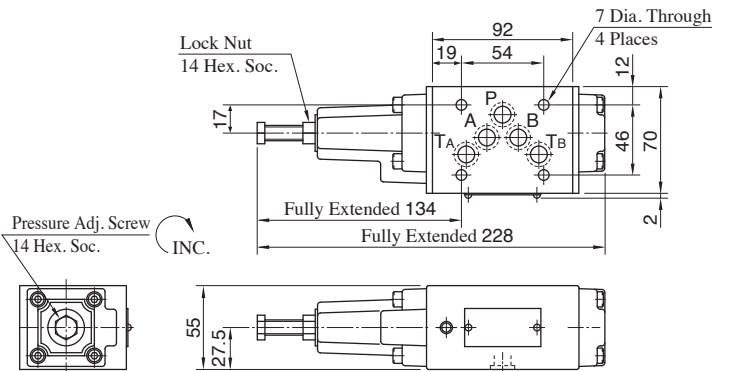

Approx. Mass.....3.5 kg

MHB-03

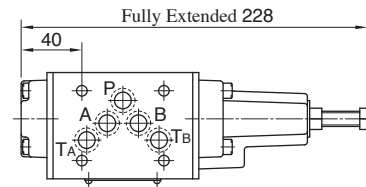

Approx. Mass.....3.5 kg

For other dimensions, refer to "MHA-03" in the drawing left..

List of Seals

MHP-03, MHA-03, MHB-03

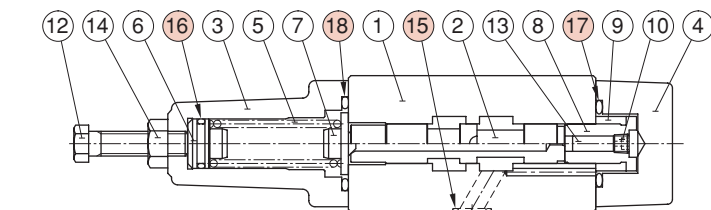

MHP-03

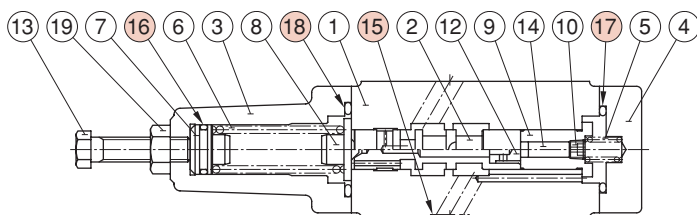

MHA-03

● MHB-03: The pressure adjustment part is assembled on the right side.

Item	Name of Parts	Part Numbers	Qty.
15	O-Ring	AS568-014 (NBR-90)	5
16	O-Ring	OR NBR-90 P16-N (OR NBR-70-1 P16-N)*	1
17	O-Ring	OR NBR-90 P29-N	1
18	O-Ring	OR NBR-90 P32-N	1

★ If use MHP-03, the O-Ring of item 16 use the one within brackets.

Pressure and Temperature Compensated Flow Control (and Check) Modular Valves

Specifications

Model Numbers	Max. Operating Pressure MPa	Max. Flow L/min	Free Flow L/min
MFP-03-11	16	50	—
MF*-03-*-11			70

Model Number Designation

MFA	-03	-X	-11
Series Number	Valve Size	Direction of Flow	Design Number
MFP: Pressure & Temperature Compensated Flow Control Valve for P-Line	03	—	11
MFA: Pressure & Temperature Compensated Flow Control & Check Valve for A-Line MFB: Pressure & Temperature Compensated Flow Control & Check Valve for B-Line MFW: Pressure & Temperature Compensated Flow Control & Check Valve for A&B-Lines		X: Meter-out Y: Meter-in	11

Instructions

- To make flow adjustment, loosen locking screw for the dial and turn the flow adjustment dial clockwise or anti-clockwise. Be sure to re-tighten the locking screw firmly after the adjustment of the flow rate.

Typical Performance Characteristics

Hydraulic Fluid: Viscosity 35 mm²/s, Specific Gravity 0.850

Min. Required Pressure Difference

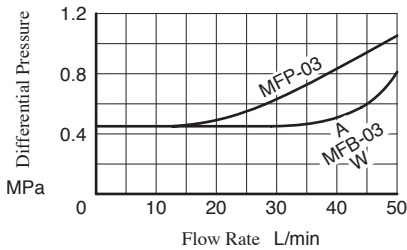

Min. Metered Flow

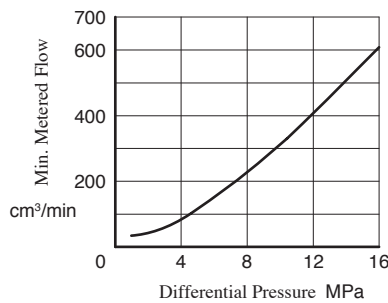

Metered Flow vs. Dial Position

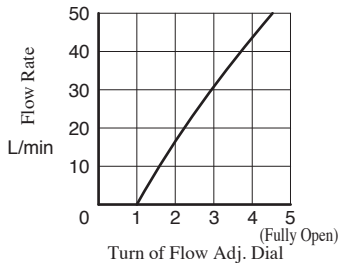

Pressure Drop

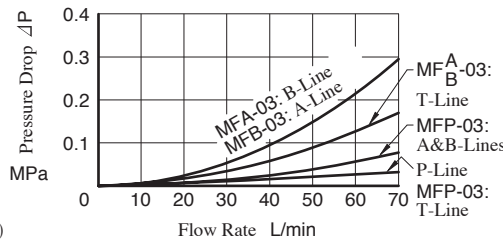

Pressure Drop for Free Flow

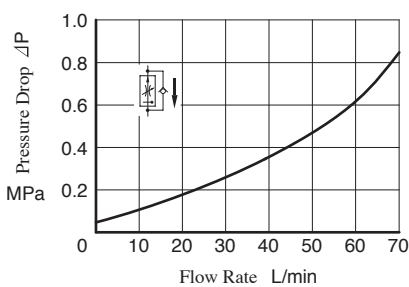

Metered Flow vs. Viscosity

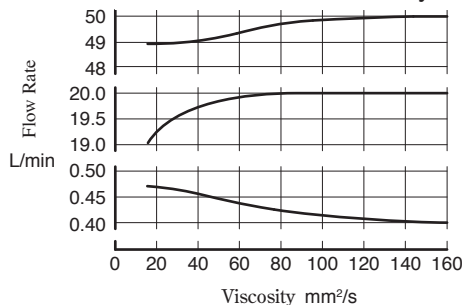

Metered Flow vs. Differential Pressure

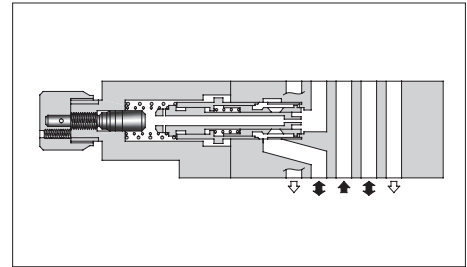
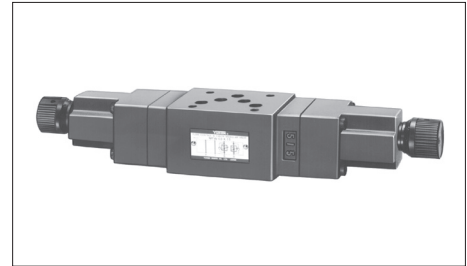
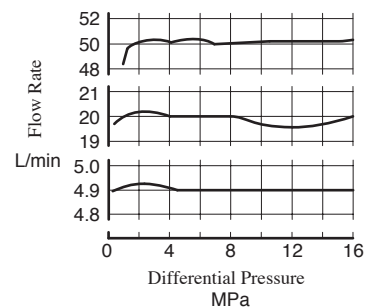

Model Numbers	Graphic Symbols
MFP-03	

Model Numbers	Graphic Symbols
MFA-03 -X	

MFB-03 -X	
MFW-03 -X	

Model Numbers	Graphic Symbols
MFA-03 -Y	

MFB-03 -Y	
MFW-03 -Y	

MFP-03

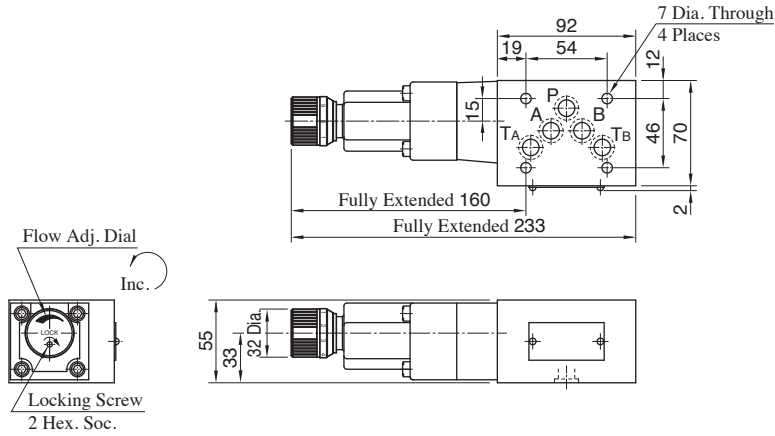

MFW-03-X Y

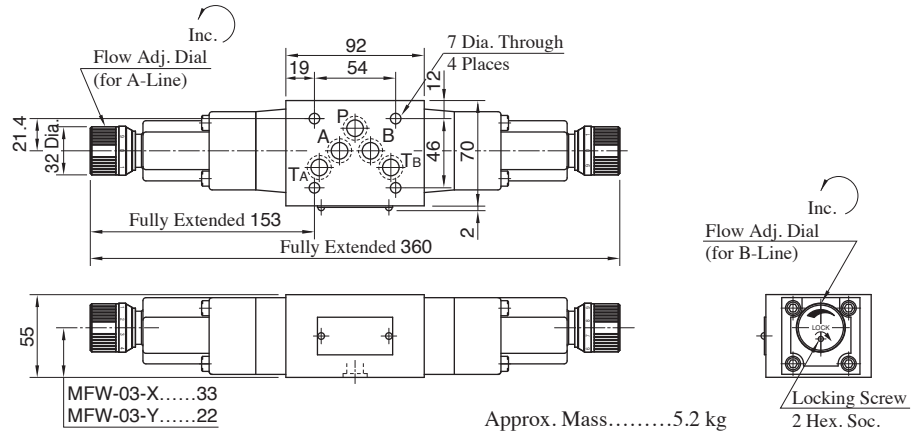

MFA-03-X Y

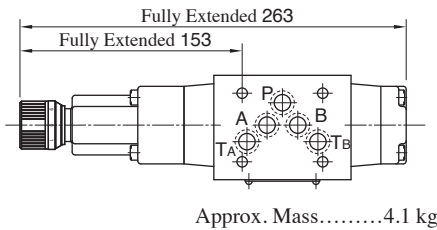

MFB-03-X Y

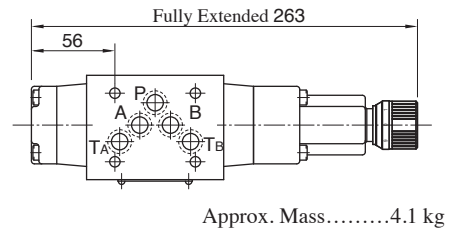

For other dimensions, refer to "MFW-03" in the drawing above.

List of Seals

MFP-03
MFA-03
MFB-03
MFW-03

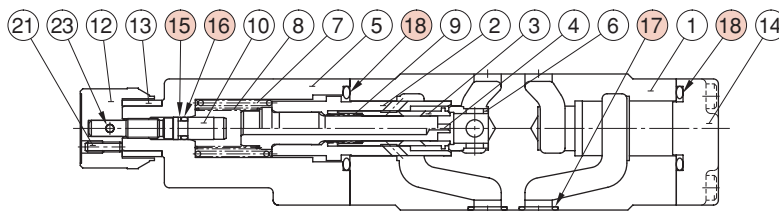

MFA-03

- MFP-03: The body ① is different.
- MFB-03: The flow adjustment part is built in the right side.
- MFW-03: The flow adjustment part is built in the both left and right sides.

Item	Name of Parts	Part Numbers	Qty.			
			MFP-03	MFA-03	MFB-03	MFW-03
15	Back-up Ring	BR JIS B 2401-4-T2-P6	1	1	1	2
16	O-Ring	OR NBR-70-1 P6-N	1	1	1	2
17	O-Ring	AS568-014 (NBR-90)	5	5	5	5
18	O-Ring	OR NBR-90 P28-N	1	2	2	2

Temperature Compensated Throttle and Check Modular Valves

Specifications

Model Numbers	Max. Operating Pressure MPa	Max. Differential Pressure MPa	Max. Metered Flow L/min	Min. Metered Flow L/min	Max. Free Flow L/min
MST*-03-X-20	25	25	70	2 (1)*	70

*The figures in parentheses are the values when the differential pressure is less than 3.5 MPa.

Model Number Designation

MSTA	-03	-X	-20
Series Number	Valve Size	Direction of Flow	Design Number
MSTA: for A-Line MSTB: for B-Line MSTW: for A&B-Lines	03	X: Meter-out	20

Temperature Compensated Throttle and Check Valve

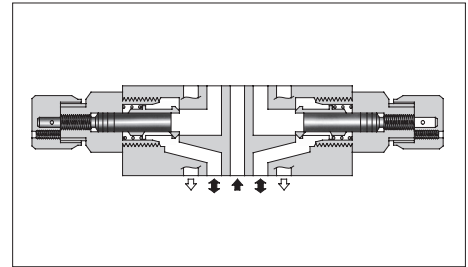
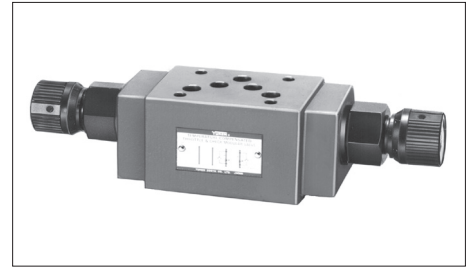

Typical Performance Characteristics

Hydraulic Fluid: Viscosity 35 mm²/s, Specific Gravity 0.850

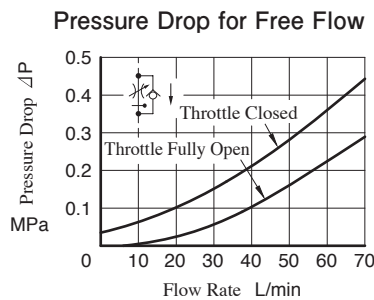
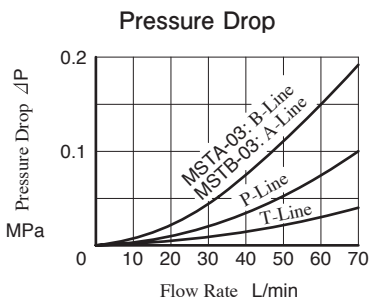

Metered Flow vs. Dial Position

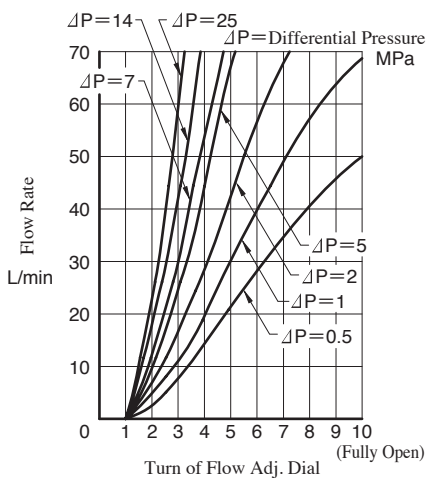

Metered Flow vs. Viscosity

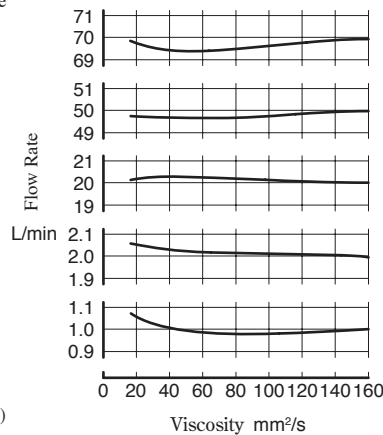

Model Numbers	Graphic Symbols	Detailed Graphic Symbols
	Meter-out	
MSTA-03-X		
MSTB-03-X		
MSTW-03-X		

Instructions

- To make flow rate adjustment, loosen locking screw for the dial and turn the flow adjustment dial clockwise or anti-clockwise. For a decrease of flow, turn the dial clockwise. Be sure to re-tighten the locking screw firmly after the adjustment of the flow rate.

Pressure Drop at Throttle Fully Open

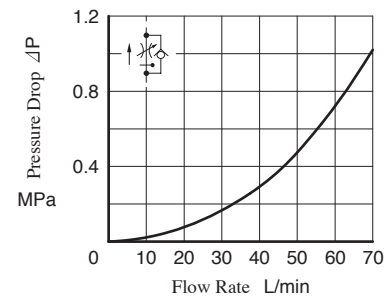

MSTW-03-X

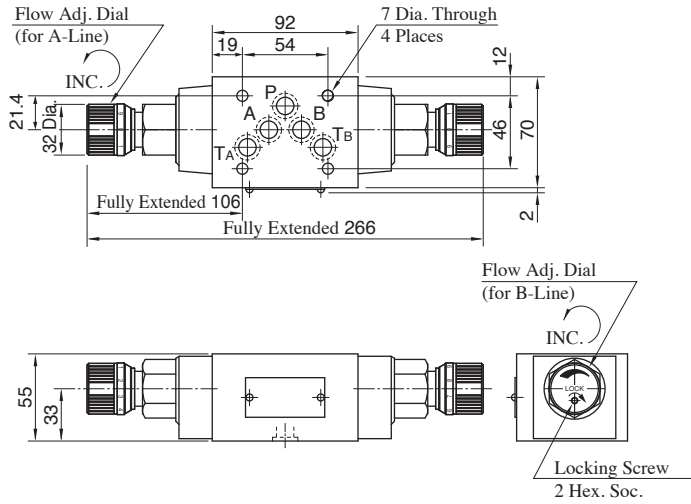

Approx. Mass.....3.7 kg

MSTA-03-X

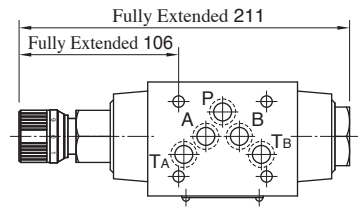

Approx. Mass.....3.5 kg

For other dimensions, refer to "MSTW-03" in the drawing left.

MSTB-03-X

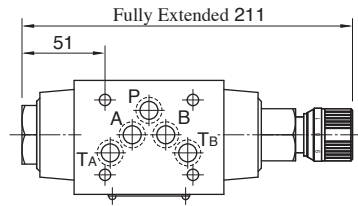

Approx. Mass.....3.5 kg

For other dimensions, refer to "MSTW-03" in the drawing left.

List of Seals

MSTA-03-X
MSTB-03-X
MSTW-03-X

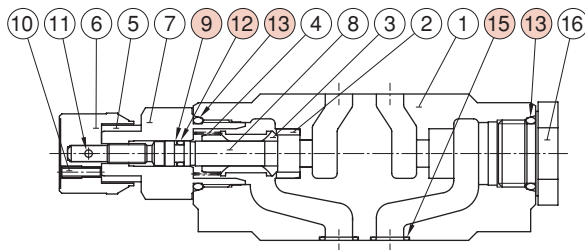

MSTA-03-X

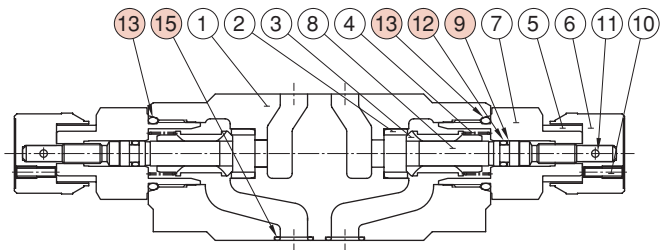

MSTW-03-X

●MSTB-03-X : The pressure adjustment part is built in the right side.

Item	Name of Parts	Part Numbers	Qty.		
			MSTA-03	MSTB-03	MSTW-03
9	Back-up Ring	900-VK411915-2	1	1	2
12	O-Ring	OR NBR-70-1 P7-N	1	1	2
13	O-Ring	OR NBR-90 P24-N	2	2	2
15	O-Ring	AS568-014 (NBR-90)	5	5	5

Throttle Modular Valves

Specifications

Model Numbers	Max. Operating Pressure MPa	Max. Flow L/min
MSP-03-30	25	70 *

★ Maximum flow decreases when the differential pressure is less than 1 MPa. See the "Pressure Drop at Throttle Fully Open" of this page.

Model Number Designation

MSP	-03	-30
Series Number	Valve Size	Design Number
MSP: Throttle Valve for P-Line	03	30

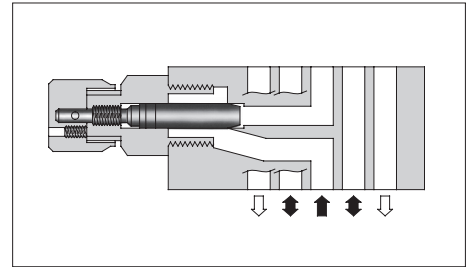
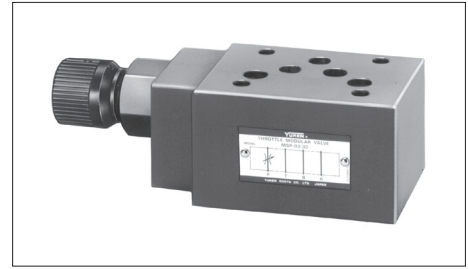

Graphic Symbols

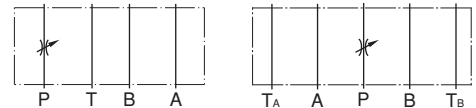

Instructions

- To make flow adjustment, loosen locking screw for the dial and turn the flow adjustment dial clockwise or anti-clockwise. Be sure to re-tighten the locking screw firmly after the adjustment of the flow rate.

Typical Performance Characteristics

Hydraulic Fluid: Viscosity 35 mm²/s, Specific Gravity 0.850

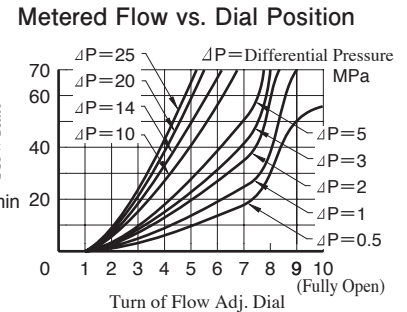
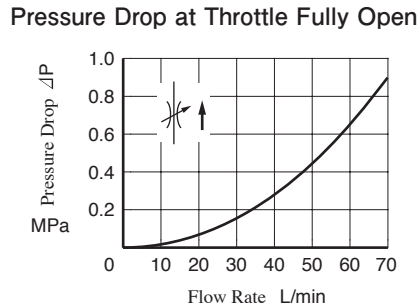
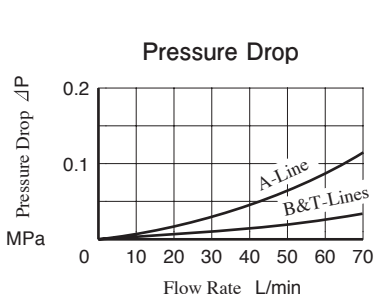

MSP-03

Approx. Mass.....3.0 kg

List of Seals

MSP-03

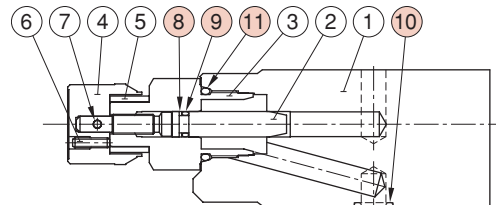

Item	Name of Parts	Part Numbers	Qty.
8	Back-up Ring	900-VK411915-2	1
9	O-Ring	OR NBR-70-1 P7-N	1
10	O-Ring	AS568-014 (NBR-90)	5
11	O-Ring	OR NBR-90 P24-N	1

Check and Throttle Modular Valves

Specifications

Model Numbers	Max. Operating Pressure MPa	Max. Flow L/min
MSCP-03-20	25	70 *

★Maximum flow decreases when the differential pressure is less than 0.8 MPa. See the "Pressure Drop at Throttle Fully Open" of this page.

Model Number Designation

MSCP	-03	-20
Series Number	Valve Size	Design Number
MSCP: Check & Throttle Valve for P-Line	03	20

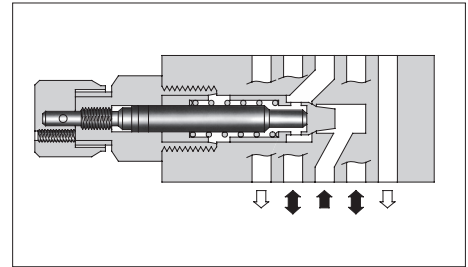
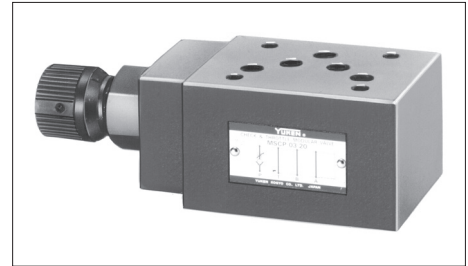

Instructions

- To make flow adjustment, loosen locking screw for the dial and turn the flow adjustment dial clockwise or anti-clockwise. Be sure to re-tighten the locking screw firmly after the adjustment of the flow rate.

Graphic Symbols

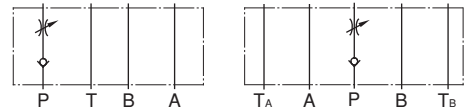

Typical Performance Characteristics

Hydraulic Fluid: Viscosity 35 mm²/s, Specific Gravity 0.850

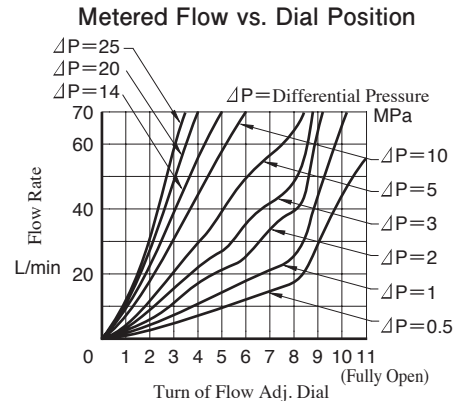
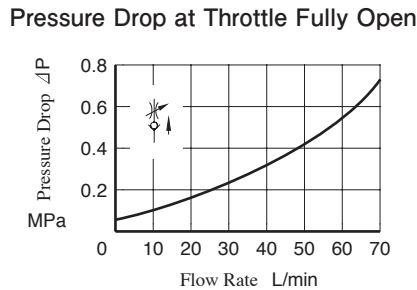
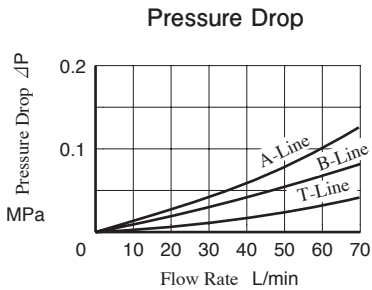

MSCP-03

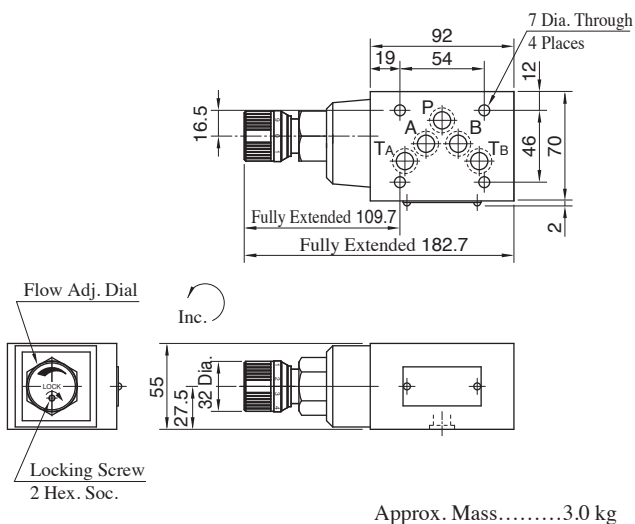

List of Seals

MSCP-03

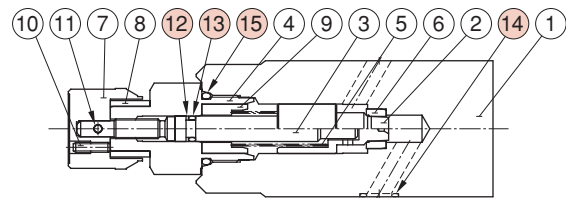

Item	Name of Parts	Part Numbers	Qty.
12	Back-up Ring	900-VK411915-2	1
13	O-Ring	OR NBR-70-1 P7-N	1
14	O-Ring	AS568-014 (NBR-90)	5
15	O-Ring	OR NBR-90 P24-N	1

03 Series Modular Valves

Throttle and Check Modular Valves

Specifications

Model Numbers	Max. Operating Pressure MPa	Max. Flow L/min
MS*-03*-70	35	160

Model Number Designation

MSA	-03	-X	-70
Series Number	Valve Size	Direction of Flow	Design Number
MSA: Throttle & Check Valve for A-Line MSB: Throttle & Check Valve for B-Line MSW: Throttle & Check Valve for A&B-Lines	03	X: Meter-out Y: Meter-in	70

Typical Performance Characteristics

Hydraulic Fluid: Viscosity 35 mm²/s, Specific Gravity 0.850

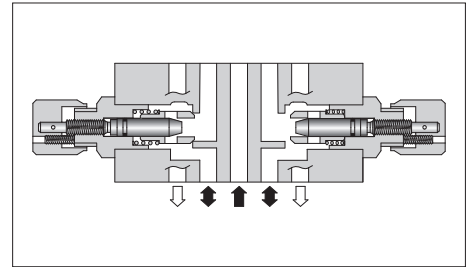
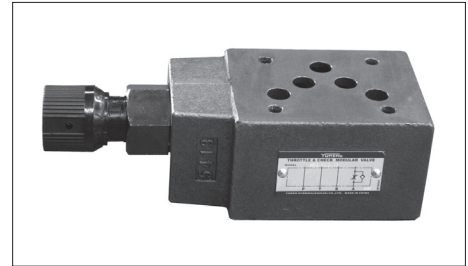
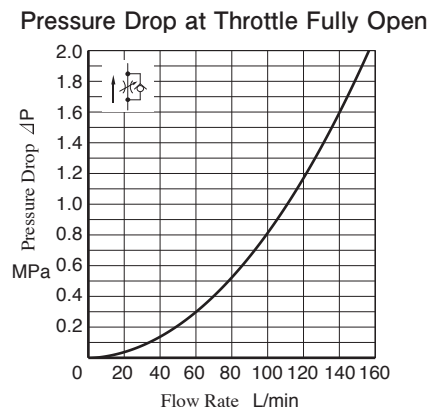
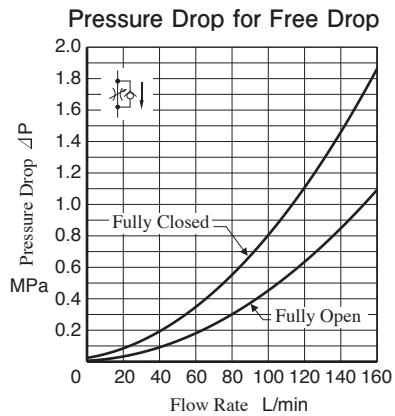
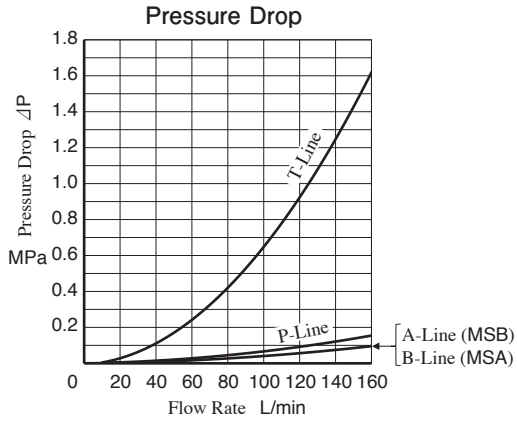

Model Numbers	Graphic Symbols	
MSA-03 -X		
MSB-03 -X		
MSW-03 -X		

Model Numbers	Graphic Symbols	
MSA-03 -Y		
MSB-03 -Y		
MSW-03 -Y		

Metered Flow vs. Dial Position

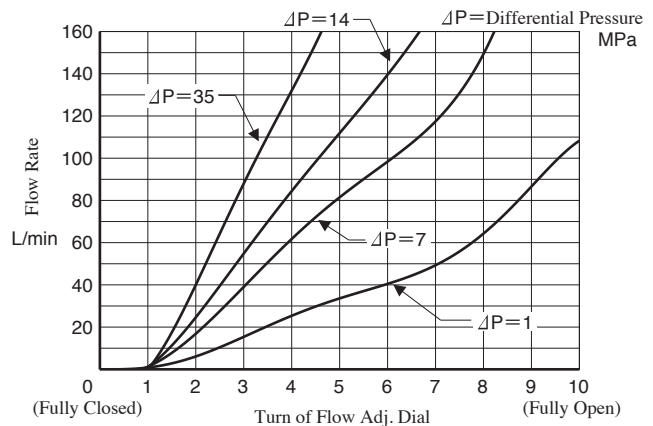

Instructions

- To make flow adjustment, loosen locking screw for the dial and turn the flow adjustment dial clockwise or anti-clockwise. Be sure to re-tighten the locking screw firmly after the adjustment of the flow rate.

MSW-03-X/Y

Approx. Mass.....3.5 kg

MSA-03-X/Y

Approx. Mass.....2.8 kg

For other dimensions, refer to "MSW-03" in the drawing left.

MSB-03-X/Y

Approx. Mass.....2.8 kg

For other dimensions, refer to "MSW-03" in the drawing left.

List of Seals

MSA-03
MSB-03
MSW-03

MSA-03

- MSB-03 : The flow adjustment part is built in the right side.
- MSW-03 : The flow adjustment part is built in the both left and right sides.

Item	Name of Parts	Part Numbers	Qty.		
			MSA-03	MSB-03	MSW-03
1	Back-up Ring	900-VK411915-2 (P7)	1	1	2
2	O-Ring	OR NBR-70-1 P7-N	1	1	2
3	O-Ring	AS568-014 (NBR-90)	5	5	5
4	O-Ring	OR NBR-90 P24-N	1	1	2

Check Modular Valves

Specifications

Model Numbers	Max. Operating Pressure MPa	Max. Flow L/min
MCP-03- *-70	35	120
MCA-03- *-70		
MCB-03- *-70		
MCW-03- *-70		
MCT-03- *-70		

Model Number Designation

MCP	-03	-0	-70
Series Number	Valve Size	Cracking Pressure MPa	Design Number
MCP:Check Valve for P-Line MCA:Check Valve for A-Line MCB:Check Valve for B-Line MCW:Check Valve for A&B-Lines MCT:Check Valve for T-Line	03	0: 0.035 2: 0.2 4: 0.4	70

Instructions

Tank Line Used

Check Valve function of MCT-03 is included in TA-Line.
Therefore, the tank line for a circuit that used this valve must be TA-Line.

Typical Performance Characteristics

Hydraulic Fluid: Viscosity 35 mm²/s, Specific Gravity 0.850

Pressure Drop for Free Flow

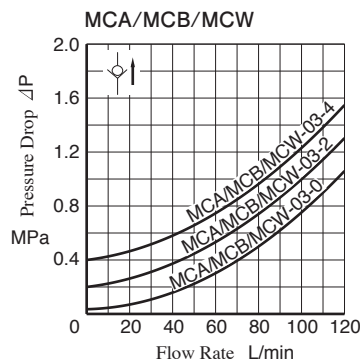
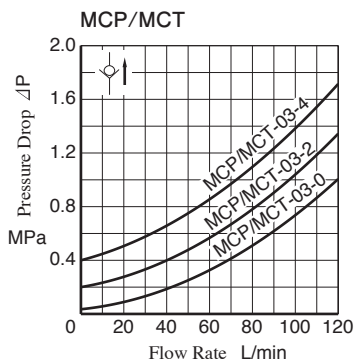

Pressure Drop

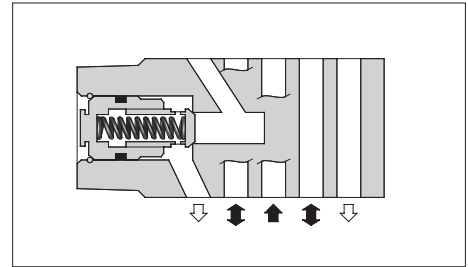
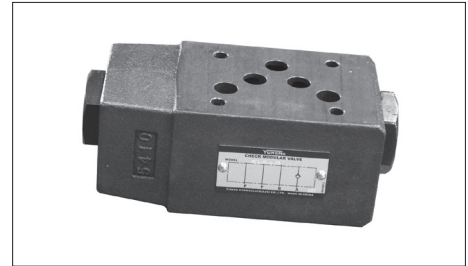
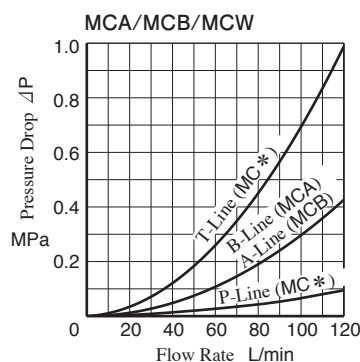
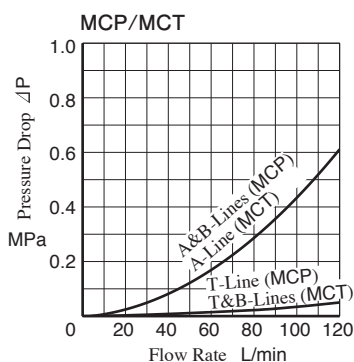

Model Numbers	Graphic Symbols	
MCP-03		
MCA-03		
MCB-03		
MCW-03		
MCT-03		

MCP-03

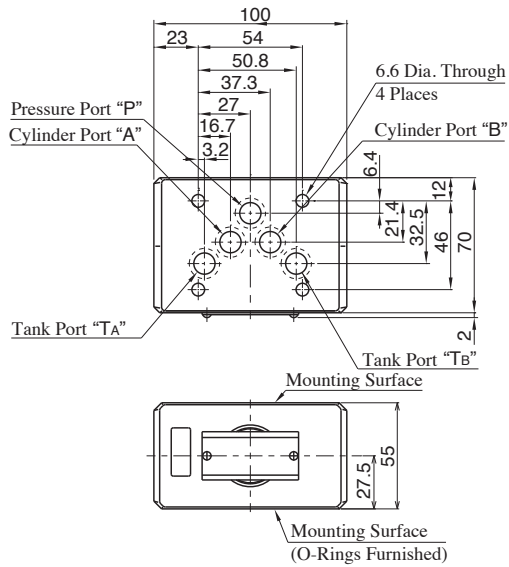

Approx. Mass.....2.6 kg

MCW-03

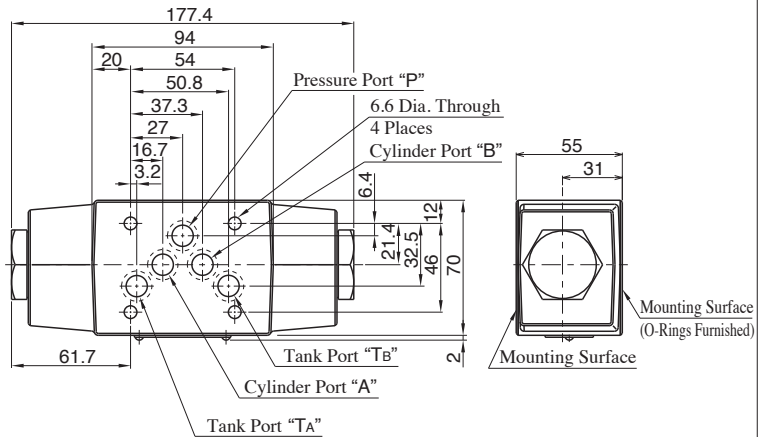

Approx. Mass.....3.7 kg

MCT-03

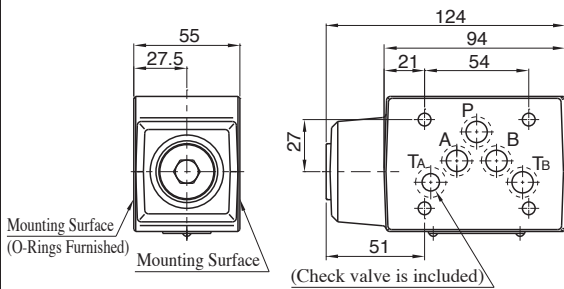

Approx. Mass.....3.0 kg

For other dimensions, refer to "MCW-03" in the drawing above.

MCA-03

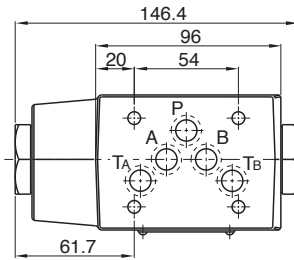

For other dimensions, refer to "MCW-03" in the drawing above.

MCB-03

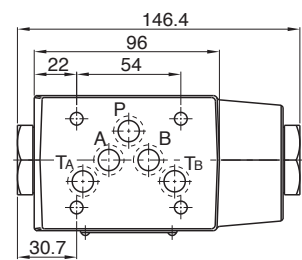

Approx. Mass.....3.0 kg

List of Seals

MCP-03

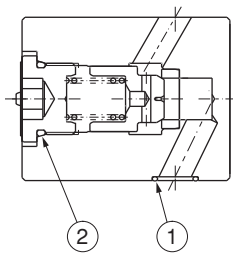

Item	Name of Parts	Part Numbers	Qty.
1	O-Ring	AS568-014 (NBR-90)	5
2	O-Ring	OR NBR-90 P21-N	1

MCT-03

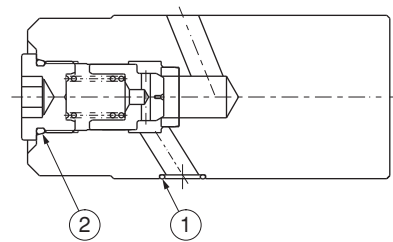

Item	Name of Parts	Part Numbers	Qty.
1	O-Ring	AS568-014 (NBR-90)	5
2	O-Ring	OR NBR-90 P21-N	1

**MCA-03
MCB-03
MCW-03**

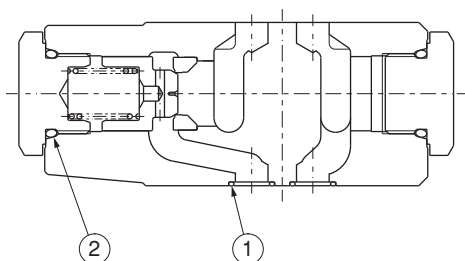

MCA-03

Item	Name of Parts	Part Numbers	Qty.
1	O-Ring	AS568-014 (NBR-90)	5
2	O-Ring	OR NBR-90 P24-N	2

- MCB-03: Check valve is assembled on the right side.
- MCW-03: Check valve is assembled on the both sides.

Check Modular Valves For “P&T” Lines

Specifications

Model Numbers	Max. Operating Pressure MPa	Max. Flow L/min
MCPT-03-P*-T*-10	25	70

Model Number Designation

MCPT	-03	-P0	-T0	-10
Series Number	Valve Size	Cracking Pressure of P-Line MPa	Cracking Pressure of T-Line MPa	Design Number
MCPT: Check Valve for P&T-Lines	03	P0: 0.035 P2: 0.2	P0: 0.035 P2: 0.2	10

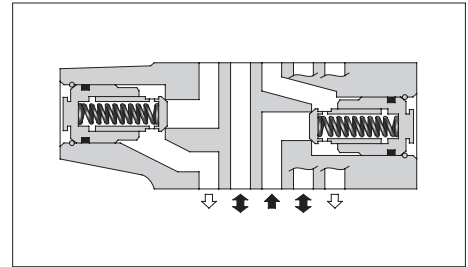
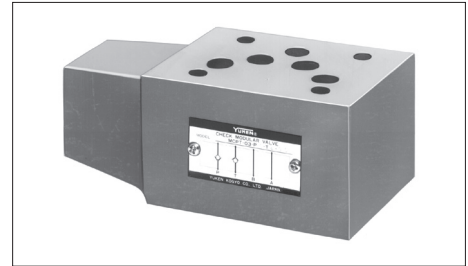

Instructions

Tank Line Used

Check Valve function of Tank Line is included in TA-Line.
Therefore, the tank line for a circuit that used this valve must be TA-Line.

Typical Performance Characteristics

Hydraulic Fluid: Viscosity 35 mm²/s, Specific Gravity 0.850

Graphic Symbols

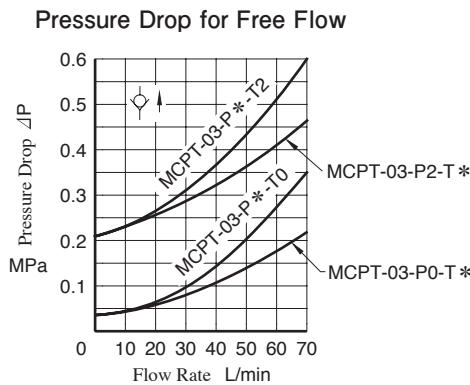
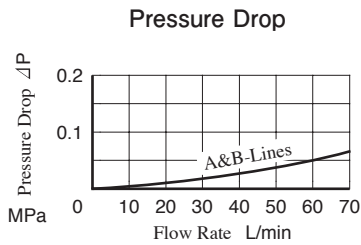
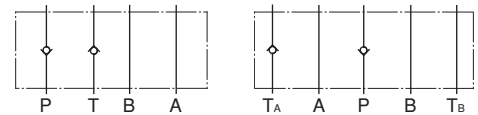

MCPT-03

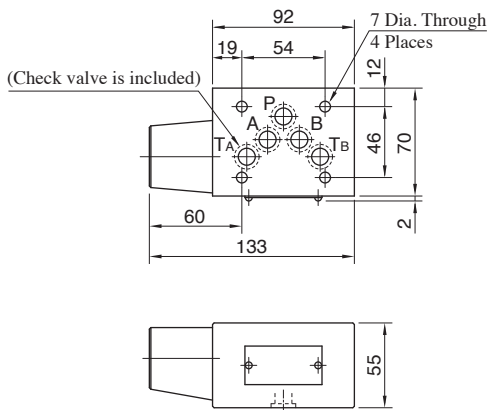

Approx. Mass.....2.7 kg

List of Seals

MCPT-03

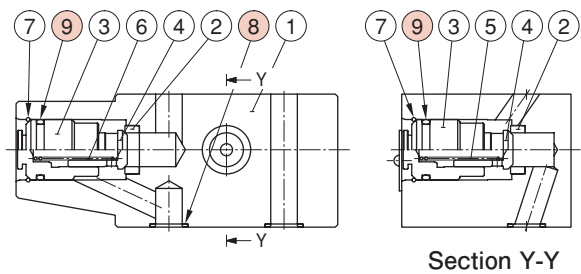

Item	Name of Parts	Part Numbers	Qty.
8	O-Ring	AS568-014 (NBR-90)	5
9	O-Ring	OR NBR-90 P21-N	2

Anti-Cavitation Modular Valves

Specifications

Model Numbers	Max. Operating Pressure MPa	Max. Flow L/min
MAC-03-10	25	70

Model Number Designation

MAC	-03	-10
Series Number	Valve Size	Design Number
MAC: Anti-Cavitation Valve	03	10

Typical Performance Characteristics

Hydraulic Fluid: Viscosity 35 mm²/s, Specific Gravity 0.850

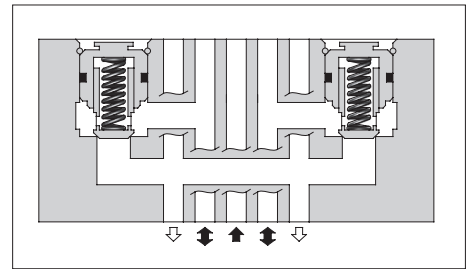
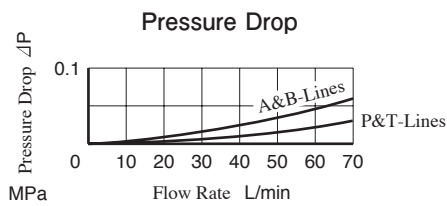

Graphic Symbols

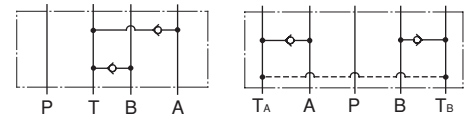

MAC-03

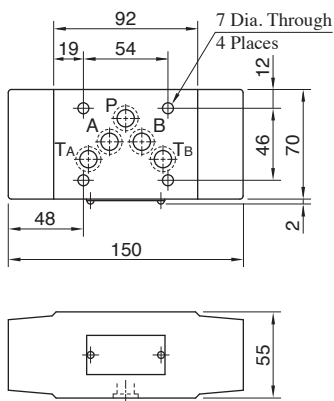

Approx. Mass.....3.8 kg

List of Seals

MAC-03

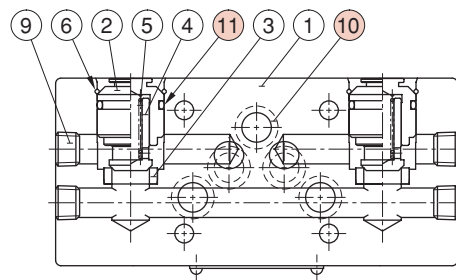

Item	Name of Parts	Part Numbers	Qty.
10	O-Ring	AS568-014 (NBR-90)	5
11	O-Ring	OR NBR-90 P21-N	2

03 Series Modular Valves

Pilot Operated Check Modular Valves

Specifications

Model Numbers		Max. Operating Pressure MPa	Max. Flow L/min
Standard	MP *-03-*-70	35	120
Low Pilot Pressure Control Type	MP *-03-*-L-70		

Model Number Designation

MPA	-03	-2	-L	-70
Series Number	Valve Size	Cracking Pressure MPa	Pilot Pressure Control Type	Design Number
MPA: Pilot Operated Check Valve for A-Line MPB: Pilot Operated Check Valve for B-Line MPW: Pilot Operated Check Valve for A&B-Lines	03	0: 0.035 2: 0.2 4: 0.4	None: Standard L: Low Pilot Pressure Control Type	70

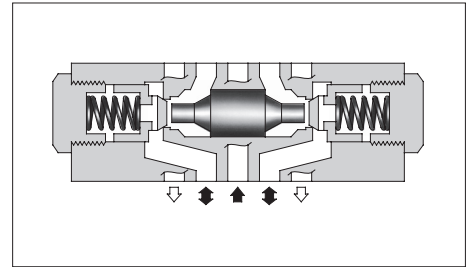
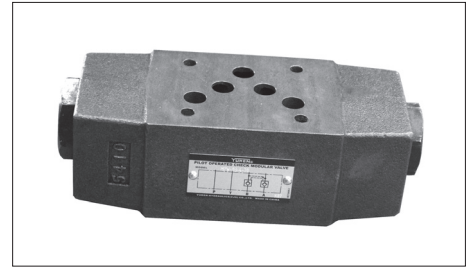

Typical Performance Characteristics

Hydraulic Fluid: Viscosity 35 mm²/s, Specific Gravity 0.850

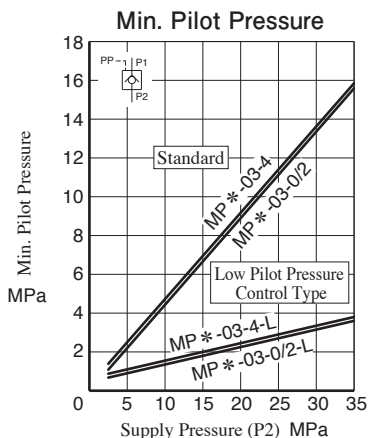
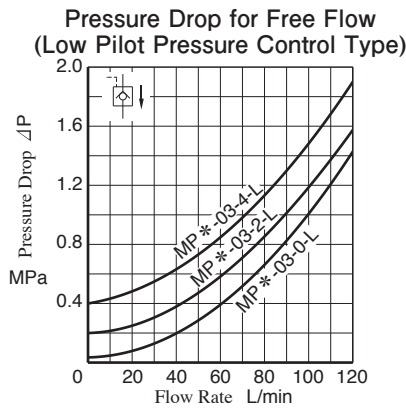
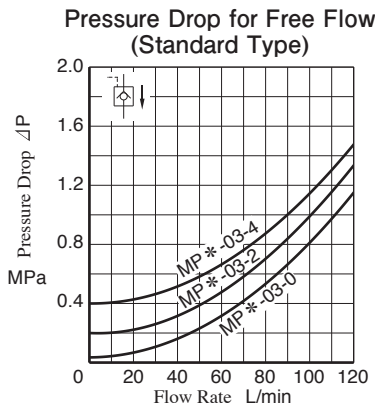
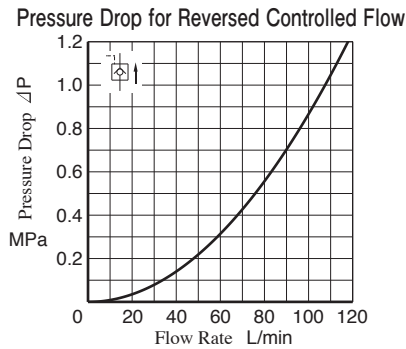
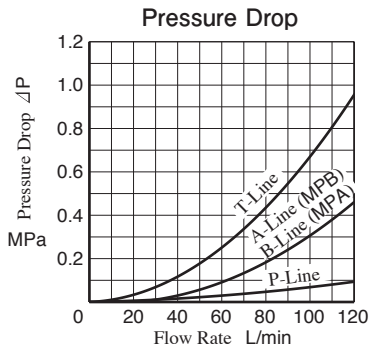

Model Numbers	Graphic Symbols	
MPA-03		
MPB-03		
MPW-03		

MPW-03

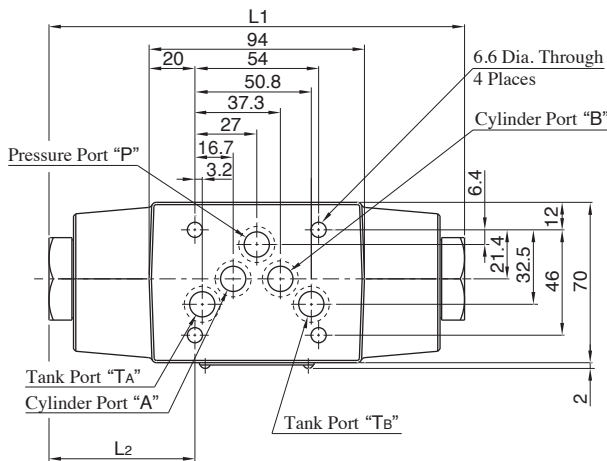

Model Numbers	L1	L2
MPW-03- *	177.4	61.7
MPW-03- *-L	181.4	63.7

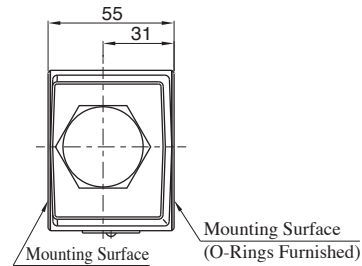

Approx. Mass.....3.7 kg

MPA-03

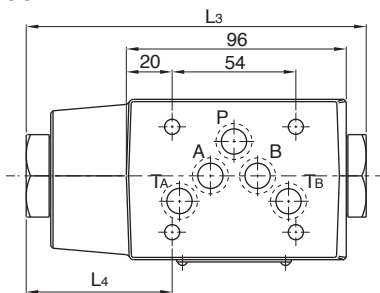

Model Numbers	L3	L4
MPA-03- *	146.4	61.7
MPA-03- *-L	148.4	63.7

Approx. Mass.....3.0 kg

For other dimensions, refer to "MPW-03" in the drawing above.

MPB-03

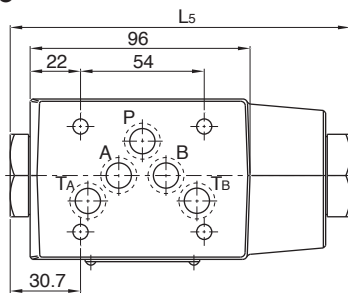

Model Numbers	L5
MPB-03- *	146.4
MPB-03- *-L	148.4

Approx. Mass.....3.0 kg

For other dimensions, refer to "MPW-03" in the drawing above.

List of Seals

MPA-03 MPB-03 MPW-03

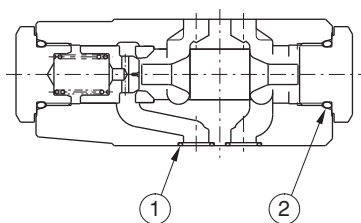

MPA-03

- MPB-03: Check valve is assembled on the right side.
- MPW-03: Check valve is assembled on the both left and right side.

Item	Name of Parts	Part Numbers	Qty.
1	O-Ring	AS568-014 (NBR-90)	5
2	O-Ring	OR NBR-90 P24-N	2

End Plates

Blocking plates are used for auxiliary mounting surface or for closing unnecessary circuits. Bypass plates are used for unidirectional circuits that require no solenoid operated directional valves.

Specifications

Model Numbers	Max. Operating Pressure MPa	Max. Flow L/min
MDC-03-* -10	25	70

Model Number Designation

MDC	-03	-A	-10
Series Number	Valve Size	Type of Plate	Design Number
MDC: End Plate	03	A: Blocking Plate B: Bypass Plate	10

Pressure Drop

Hydraulic Fluid: Viscosity 35 mm²/s,
Specific Gravity 0.850

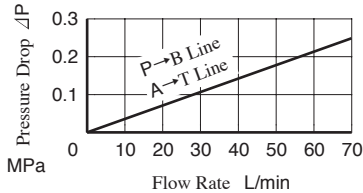

Model Numbers	Graphic Symbols	
MDC-03 -A		
MDC-03 -B		



MDC-03

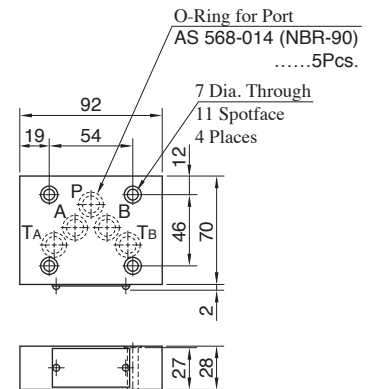

Approx. Mass.....1.2 kg

Connecting Plates

These plates are used for detecting pressure of each line.

Model Number Designation

MDS	-03	-10
Series Number	Valve Size	Design Number
MDS: Connecting Plate	03	10

Specifications

Model Numbers	Max. Operating Pressure MPa	Max. Flow L/min
MDS-03-10	25	70

Pressure Drop

Hydraulic Fluid: Viscosity 35 mm²/s,
Specific Gravity 0.850

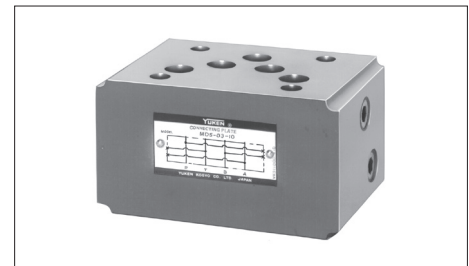
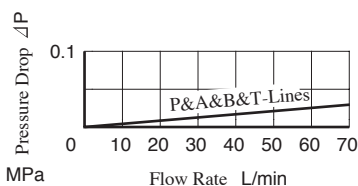

Graphic Symbols

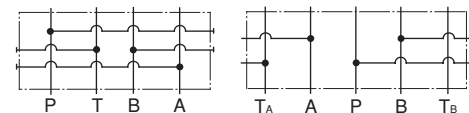

MDS-03

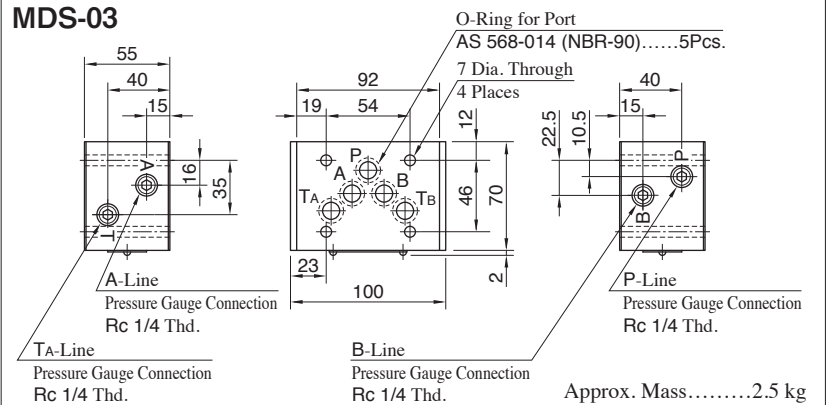

Approx. Mass.....2.5 kg

Base Plates For Modular Valves

Model Number Designation

MMC	-03	-T	-6	-21
Series Number	Plate Size	Type of Connection	Number of Stations	Design Number
MMC: Base Plate	03	T: Threaded Connection	1: 1 Station 5: 5 Stations 2: 2 Stations 6: 6 Stations 3: 3 Stations 7: 7 Stations 4: 4 Stations	21

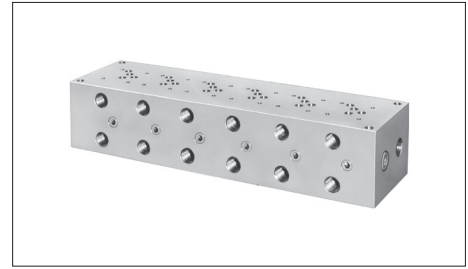

MMC-03-T-1

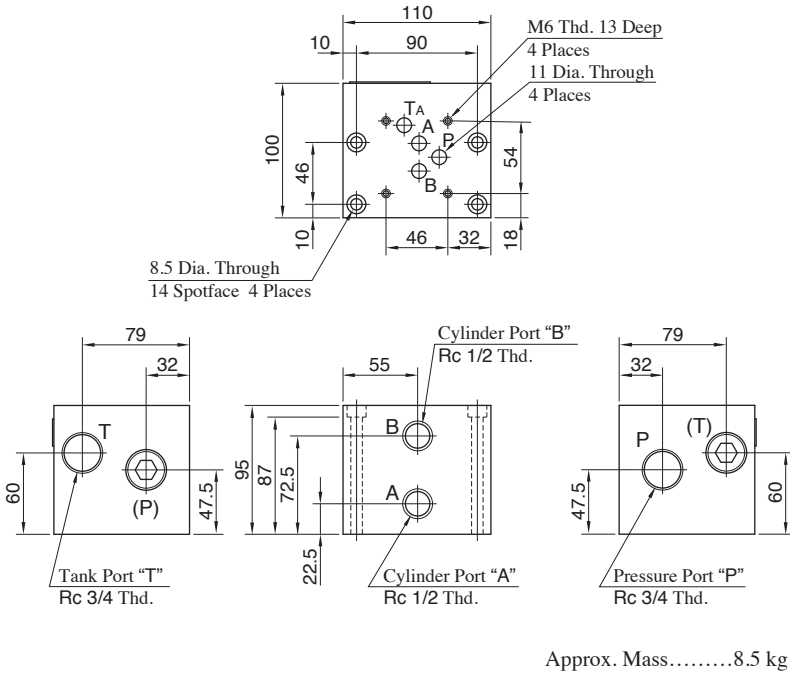

Specifications

Max. Operating Pressure.....25 MPa

Graphic Symbol Detailed Graphic Symbol

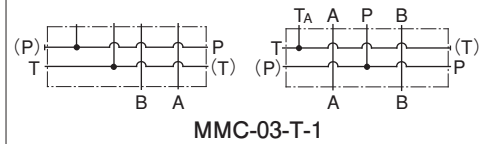

Graphic Symbol

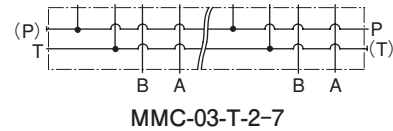

MMC-03-T-2-7

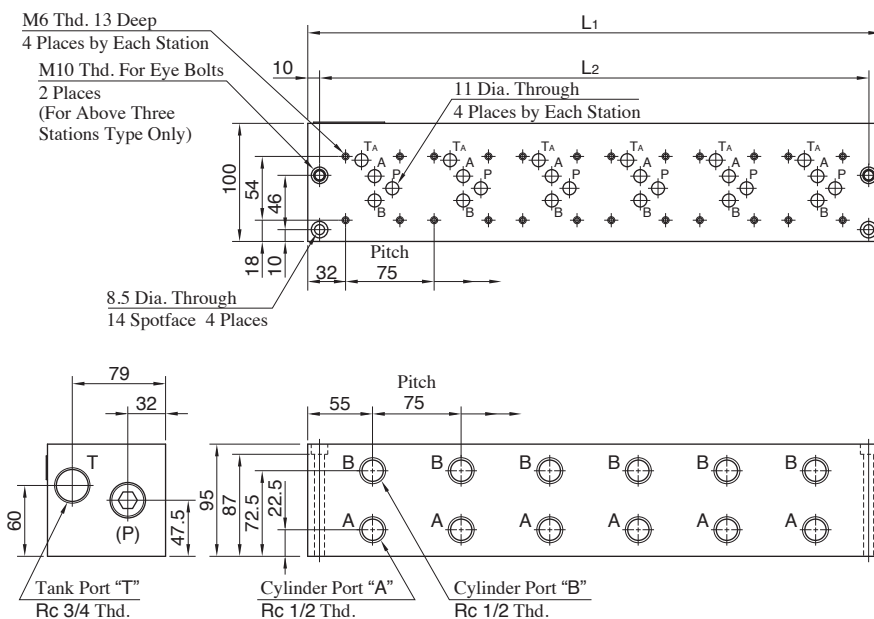

Model Numbers	L1	L2	Mass kg
MMC-03-T-2	185	165	14
MMC-03-T-3	260	240	19.5
MMC-03-T-4	335	315	25
MMC-03-T-5	410	390	30.5
MMC-03-T-6	485	465	36
MMC-03-T-7	560	540	41

03 Series Modular Valves

Pressure Drop

Hydraulic Fluid: Viscosity 35 mm²/s, Specific Gravity 0.850

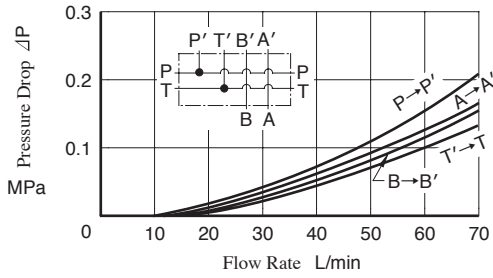

Mounting Surface Dimensions for 03 Series Modular Valve

When the standard base plate (MMC-03) is not used, the following mounting surface must be prepared. Also, the mounting surface must have a good machined finish. ($\frac{1.6}{\sqrt{R}}$)

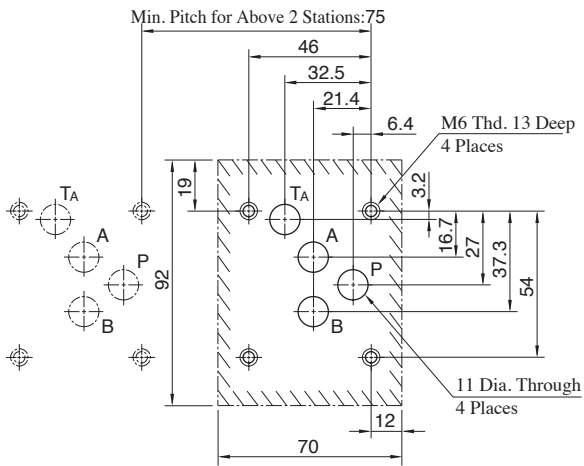

Instructions

● Although two ports are provided for both pressure port "P" and tank port "T", either may be used. However, the ports having (P) or (T) in the drawing are normally plugged. Remove the plugs of the ports when they are used. Make sure that the ports that are not currently used are properly plugged.

Spacer Kits

If 01 Series Modular Valves stacking on the 03 Base Plates, use this spacer.

If use, order by the model number below.

Model Numbers: DSGM-03-4010

Approx. Mass: 1kg

Accessories: Mounting Bolt 4 Pcs. : M6x25L

O-Ring 5 Pcs. : AS568-014 (NBR-90)

DSGM-03-4010

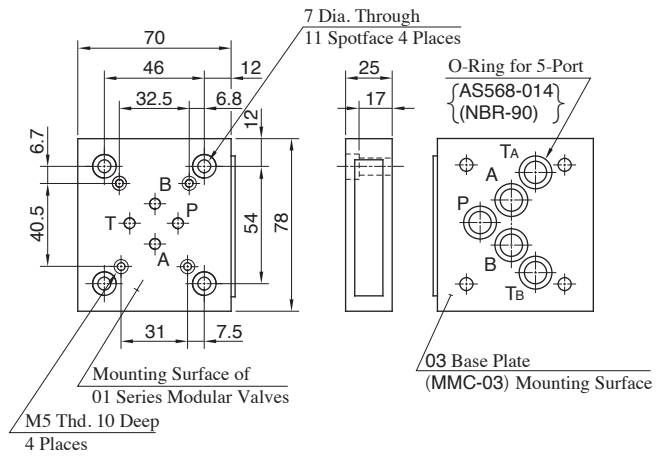

Note:

In the spacer above, 01 side "A" ⇔ 03 side "B", 01 side "B" ⇔ 03 side "A" are connected.

Mounting Bolt Kits For Modular Valves

Valves are mounted with four M6 stud bolts. Valve combination varies according to the circuit type. Hence, the mounting bolt kits are available on a combination type basis.

When ordering the mounting bolt kit, be sure to give the bolt kit model number from the table below.

Model Number Designation

MBK	-03	-04	-10
Series Number	Size of Modular Valve	Bolt Number	Design Number
MBK: Mounting Bolt Kits for Modular Valve	03	01, 02, 03, 04, 05 (Refer to the following chart)	10

Bolt Kits Selection Chart

Model Numbers	Quantity of valves to be stacked			Approx. Mass (1 Set) g
	Solenoid Operated Directional Valve (*-DSG-03)	End Plate (MDC-03)	Modular Valve or Connecting Plate (M** *-03)	
MBK-03-01-10	1	0	1	120
	0	1		
MBK-03-02-10	1	0	2	160
	0	1		
MBK-03-03-10	1	0	3	200
	0	1		
MBK-03-04-10	1	0	4	240
	0	1		
MBK-03-05-10	1	0	0	40
	0	1		



Bolt Kit Composition

Stud Bolt 4 Pcs. } 1 Set
Nut 4 Pcs. }

Note: In case of bolt kit model number having "05", four hexagon socket head cap screws only.

Tightening Torque..... 12-15 Nm

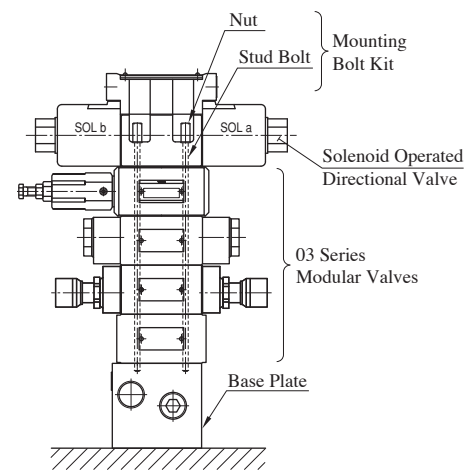

Stacking Example

MBK-03

Stud Bolt

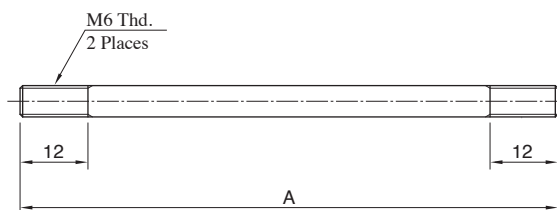

Nut

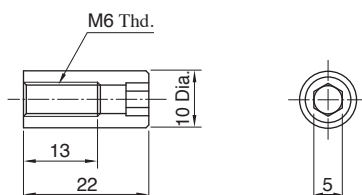

Bolt Number	A mm
01	103
02	158
03	213
04	268
05	Socket Head Cap Screw M6×35 L.

Interchangeability in Installation between Current and New Design

The following models of 03 Series Modular Valves have changed to 70 design numbers model to operate higher pressure and modification for large flow use.

Name	Model Numbers
Relief Modular Valves	MB * -03- * -70
Reducing Modular Valves	MR * -03- * -70
Throttle and Check Modular Valves	MS * -03- * -70
Check Modular Valves	MC * -03- * -70
Pilot Operated Check Modular Valves	MP * -03- * - * -70

Major Changes

- Max. Operating Pressure (35MPa) & Max. Flow have substantially increased respectively.
- Selectable low pilot operation type as standard model for Pilot Operated Check Modular Valves.

Mounting Interchangeability

Yes

Mounting surface is not changed from current models.

Specifications

Max. Operating Pressure

Name	Current		New	
	Model Numbers	Max. Operating Pressure MPa	Model Numbers	Max. Operating Pressure MPa
Relief Modular Valves	MB * -03- * -30	31.5	MB * -03- * -70	35
Reducing Modular Valves	MR * -03- * -30	25	MR * -03- * -70	
Throttle and Check Modular Valves	MS * -03- * -40		MS * -03- * -70	
Check Modular Valves	MCP/MCT-03- * -10 MCA/MCB/MCW-03- * -20		MC * -03- * -70	
Pilot Operated Check Modular Valves	MP * -03- * -20		MP * -03- * -70	
	MP * -03- * -2001		MP * -03- * -L-70	

Max. Flow

Name	Current		New	
	Model Numbers	Max. Flow L/min	Model Numbers	Max. Flow L/min
Relief Modular Valves	MB * -03- * -30	70	MB * -03- * -70	120
Reducing Modular Valves	MR * -03- * -30	70	MR * -03-A-70	80
			MR * -03-B/C/H-70	120
Throttle and Check Modular Valves	MS * -03- * -40	120	MS * -03- * -70	160
Check Modular Valves	MCP/MCT-03- * -10 MCA/MCB/MCW-03- * -20	70	MC * -03- * -70	120
			Pilot Operated Check Modular Valves	
	MP * -03- * -2001			

● Model Number Designation

Function Addition

Name	Model Numbers	Additional Functions
Pilot Operated Check Modular Valves	MP * -03- * -L-70	Low pilot operation type, selectable as standard product

Pressure Adjustment Range

Name	Current		New	
	Model Numbers	Pres. Adj. Range MPa	Model Numbers	Pres. Adj. Range MPa
Relief Modular Valves	MB * -03- * -30	B: ★-7 H: 3.5-31.5	MB * -03- * -70	B: ★-7 C: 3.5-14 K: 7-35
Reducing Modular Valves	MR * -03- * -30	B: 1-7 H: 3.5-24.5	MR * -03- * -70	A: ★-3.5 B: 1-7 C: 3.5-14 H: 7-31.5

Cracking Pressure

Name	Current		New	
	Model Numbers	Cracking Pressure MPa	Model Numbers	Cracking Pressure MPa
Check Modular Valves	MCP/MCT-03- * -10 MCA/MCB/MCW-03- * -20	0: 0.035 2: 0.2	MC * -03- * -70	0: 0.035 2: 0.2 2: 0.4
Pilot Operated Check Modular Valves	MP * -03- * -20 MP * -03- * -2001	2: 0.2 2: 0.4	MP * -03- * -70 MP * -03- * -L-70	0: 0.035 2: 0.2 4: 0.4

● Typical Performance Characteristics

Characteristics of all models have been changed.

● Approx. Mass

Name	Current		New	
	Model Numbers	Approx. Mass kg	Model Numbers	Approx. Mass kg
Relief Modular Valves	MBP/MBA/MBB-03- * -30	3.1	MBP/MBA/MBB-03- * -70	3.4
	MBW-03- * -30	3.8	MBW-03- * -70	4.0
Reducing Modular Valves	MR * -03- * -30	3.3	MR * -03- * -70	3.8
Throttle and Check Modular Valves	MSA/MSB-03- * -40	3.5	MSA/MSB-03- * -70	2.8
	MSW-03- * -40	3.7	MSW-03- * -70	3.5
Check Modular Valves	MCP-03- * -10	2.5	MCP-03- * -70	2.6
	MCA/MCB-03- * -20	3.5	MCA/MCB-03- * -70	3.0
	MCW-03- * -20	3.5	MCW-03- * -70	3.7
	MCT-03- * -10	2.8	MCT-03- * -70	3.0
Pilot Operated Check Modular Valves	MPA/MPB-03- * -20	3.5	MPA/MPB-03- * - * -70	3.0
	MPW-03- * -2001	3.5	MPW-03- * - * -70	3.7

● Dimensions

As of fully extended dimensions, height (55mm) and depth (70mm) are same between current and new models. Width is same except for the models below.

(1) Relief Modular Valves

MBW-03

Fully Extended L1

Fully Extended L2

MBP/MBA-03

Fully Extended L1

Fully Extended L2

MBB-03

Fully Extended L1

Fully Extended L2

Model Numbers		L1	L2
Current	MBP-03- *-30	214	134
	MBA-03- *-30	214	134
	MBB-03- *-30	214	—
New	MBW-03- *-30	320	133
	MBP-03- *-70	209	132
	MBA-03- *-70	207	132
	MBB-03- *-70	207	—
MBW-03- *-70	318	132	

(2) Reducing Modular Valves

MRP/MRB-03

Fully Extended L2

MRA-03

Fully Extended L2

Model Numbers		L2
Current	MR *-03- *-30	131
New	MR *-03- *-70	131.3

(3) Throttle and Check Modular Valves

MSW-03

Fully Extended L1

Fully Extended L2

MSA-03

Fully Extended L1

Fully Extended L2

MSB-03

Fully Extended L1

Fully Extended L2

Model Numbers		L1	L2
Current	MSA-03- *-40	193.5	91.5
	MSB-03- *-40	193.5	
	MSW-03- *-40	237	
New	MSA-03- *-70	180	106
	MSB-03- *-70	180	
	MSW-03- *-70	266	

(4) Check Modular Valves

MCA-03

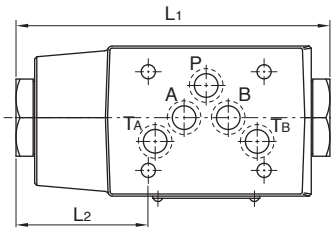

MCB-03

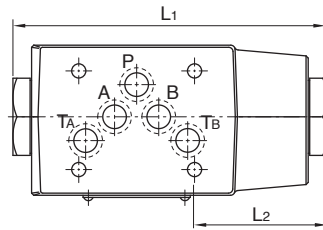

MCW-03

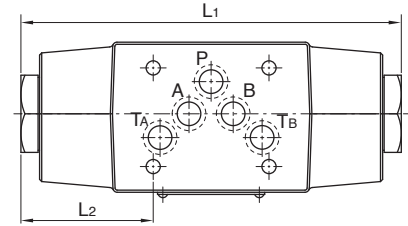

MCT-03

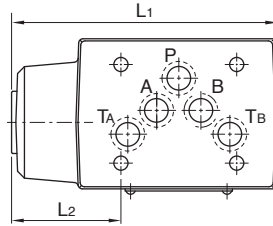

Model Numbers		L ₁	L ₂
Current	MCA/MCB-03- *-20	174	60
	MCW-03- *-20	174	60
	MCT-03- *-10	117	44
New	MCA/MCB-03- *-70	146.4	61.7
	MCW-03- *-70	177.4	61.7
	MCT-03- *-70	124	51

(5) Pilot Operated Check Modular Valves

MPA-03- *
MPA-03- *-L

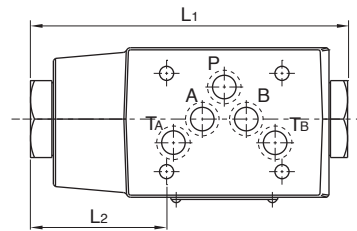

MPB-03- *
MPB-03- *-L

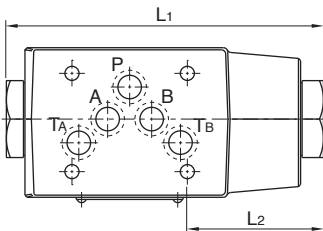

MPW-03- *
MPW-03- *-L

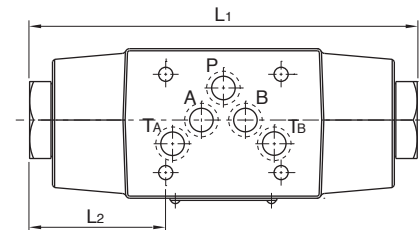

Model Numbers		L ₁	L ₂
Current	MPA/MPB-03- *-20	174	60
	MPW-03- *-20	174	60
	MPA/MPB-03- *-2001	178	62
	MPW-03- *-2001	178	62
New	MPA/MPB-03- *-70	146.4	61.7
	MPW-03- *-70	177.4	61.7
	MPA/MPB-03- *-L-70	148.4	63.7
	MPW-03- *-L-70	181.4	63.7