

Proportional Electro-Hydraulic Directional and Flow Control Valves

These valves are double-deck directional and flow control valves employing as their pilot the electro-hydraulic proportional pressure reducing valves with two proportional solenoids. The flow rate can be controlled by changing an input current to the solenoids and the direction of the flow can be controlled by providing the current to either solenoid of the two.

By combining the valves with the power amplifiers specially designed for the valves, the speed control, acceleration, deceleration and directional control can be done with a single valve, which eventually makes the hydraulic circuits simple and contributes the cost of the hydraulic systems.

Specifications

Descriptions		Model No.	EDFHG-03	EDFHG-04	EDFHG-06
Max. Operating Pressure		MPa	25		
Rated Flow ^{★1}		L/min	100	140	280
at Valve Pressure Difference: 1.0 MPa					
Pilot Pressure ^{★2}		MPa	1.5 - 16		
Pilot Flow	L/min	at Normal	1	1	1
		at Transition	3	4	6
Max. Tank Line Back Pressure		MPa	16	21	21
Max. Drain Line Back Pressure ^{★3}		MPa	3.0		
Rated Current		mA	800	980	900
Coil Resistance		Ω	10		
Hysteresis			5% or less ^{★4}		
Repeatability			1% or less ^{★4}		
Approx. Mass		kg	11	12	15

★1. The rated flow rate is valid at a differential pressure of 1.0 MPa of “P→A(B)” or “A(B)→T.”

★2. Take care to keep the difference between the pilot pressure and drain port back pressure consistently greater than 1.5 MPa.

★3. To obtain stable performance, keep the drain port back pressure low and minimize its fluctuations.

★4. The hysteresis and repeatability values indicated in the specifications for each control valve are determined under the following conditions:

- Hysteresis Value: Obtained when Yuken's applicable power amplifier is used.
- Repeatability Value: Obtained when Yuken's applicable power amplifier is used under the same conditions.

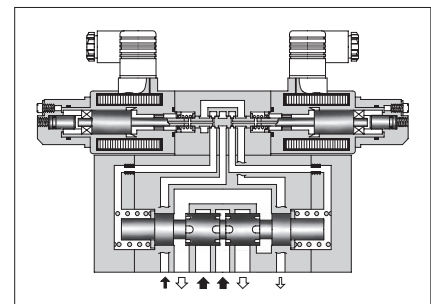
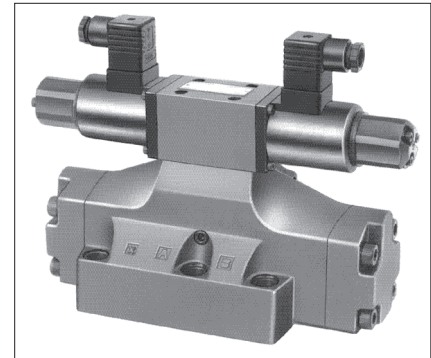

Graphic Symbols

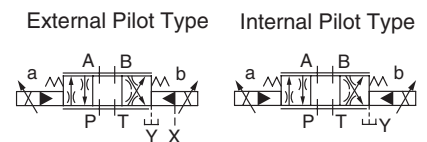

Model Number Designation

EDFH	G	-03	-100	-3C2	-XY	-E	-31
Series Number	Type of Mounting	Valve Size	Rated Flow L/min	Spool Type ^{★1}	Direction of Flow	Pilot Connection	Design Number
EDFH: Proportional Electro-Hydraulic Directional and Flow Control Valves	G: Sub-Plate Mounting	03	100	3C2 3C40 	XY: Meter-in Meter-out	E: External Pilot None: Internal Pilot	31
		04	140				31
		06	280				31

★1. Spool type shown in the column is for the center position.

Accessories

Mounting Bolts

Model Numbers	Socket Head Cap Screw	Qty.	Tightening Torque Nm
EDFHG-03	M6 × 35 L	4	12 - 15
EDFHG-04	M6 × 45 L	2	12 - 15
	M10 × 50 L	4	58 - 72
EDFHG-06	M12 × 60 L	6	100 - 123

Sub-Plate

Valve Model Numbers	Sub-Plate Model Numbers	Thread Size Rc	Approx. Mass kg
EDFHG-03	DHGM-03Y-10	3/4	4.7
EDFHG-04	DHGM-04-20	1/2	4.4
	DHGM-04X-20	3/4	4.1
EDFHG-06	DHGM-06-50	3/4	7.4
	DHGM-06X-50	1	

- Sub-plates are available. Specify the sub-plate model number from the table above. When sub-plates are not used, the mounting surface should have a good machined finish. (1/6)
- Sub-plates are those for solenoid controlled pilot operated directional valves. For details, contact us.

Applicable Power Amplifiers

For stable performance, it is recommended that Yuken's applicable power amplifiers be used (for details see page H-188).
 Model Numbers: SK1091-D24-10

Instructions

Manual Adjustment

In the event of an electric fault or emergency, a manual shift can be made by screwing in the manual adjustment screw. Take care, however, that this manual shift has no flows adjusting function. For this operation, set the pilot pressure (or P-port pressure on an internal-pilot model) below 7 MPa. After operation, be sure to return the manual adjustment screw completely to the original position.

During Piping

During piping work, special care should be taken so that the tank port "T" is constantly filled with hydraulic fluid. Because back pressure is applied, using a check valve whose cracking pressure is about 0.04 MPa is recommended. Also, connect the tank port piping directly to the oil tank, but do not connect it other piping. For this reason, be sure to immerse the pipe end in fluid.

Sub Plates: DHGM-03Y

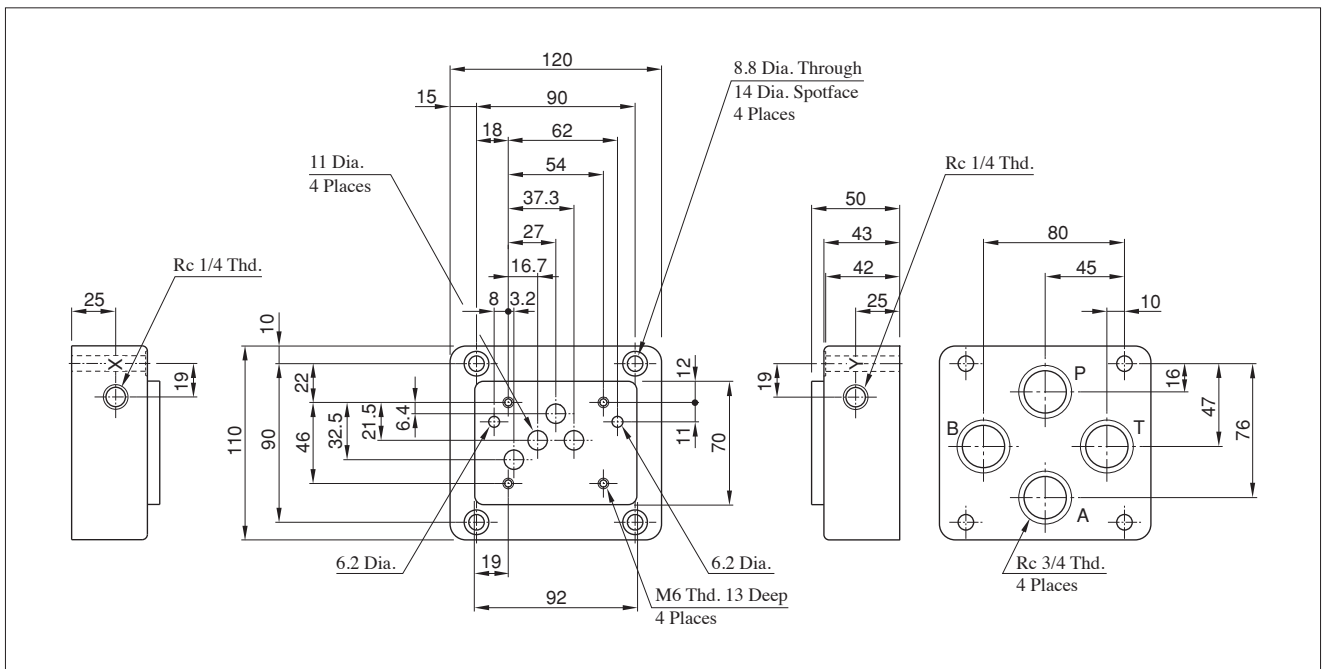

EDFHG-03

Mounting Surface: Conform to ISO 4401-05-05-0-05

★ Of the two tank ports "T", the tank port in the left side is normally used in our standard sub-plate, though, either side of the tank port "T" can be used without problem.

Note) For valve mounting surface dimensions, see the dimensional drawings of sub-plates (page H-158) in common use.

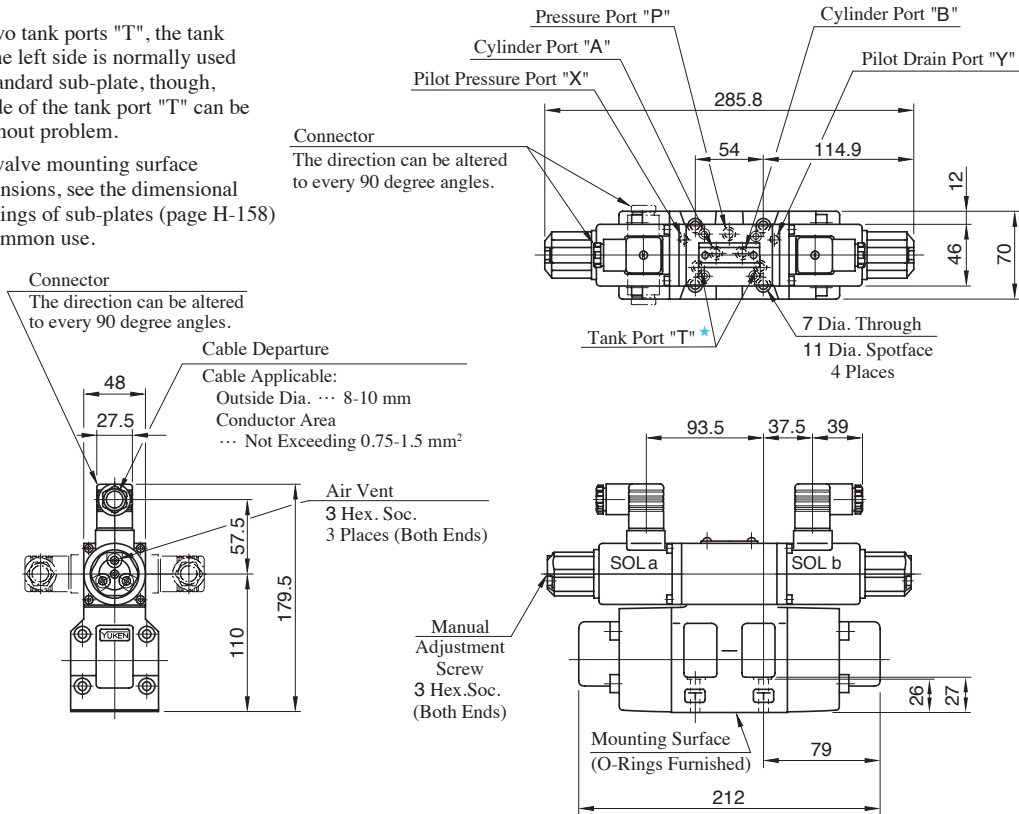

EDFHG-04

Mounting Surface: Conform to ISO 4401-07-07-0-05

★ Position of cable departure can be changed. For details, refer to above EDFHG-03.

Note) For valve mounting surface dimensions, see the dimensional drawings of sub-plates (page H-62) in common use.

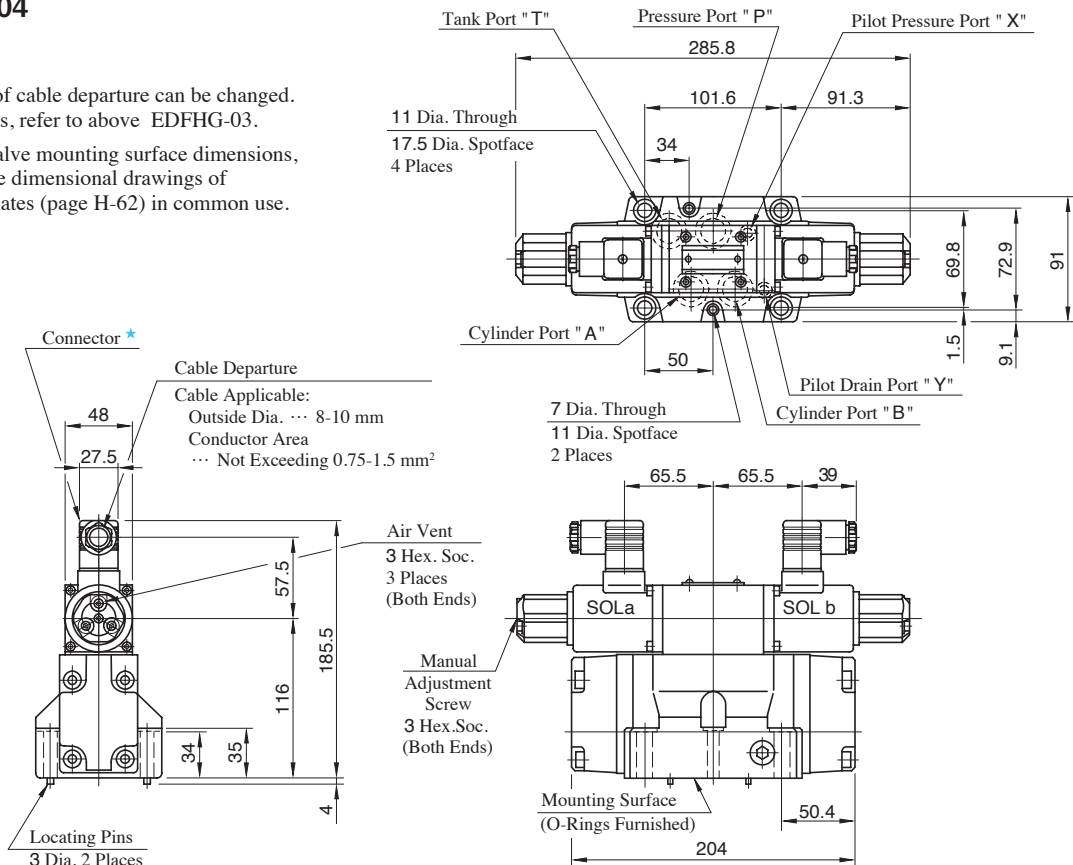

EDFHG-06

Mounting Surface: Conform to ISO 4401-08-08-0-05

★ Position of cable departure can be changed. For details, refer to EDFHG-03 valve on page H-159.

Note) For valve mounting surface dimensions, see the dimensional drawings of sub-plates (page H-62) in common use.

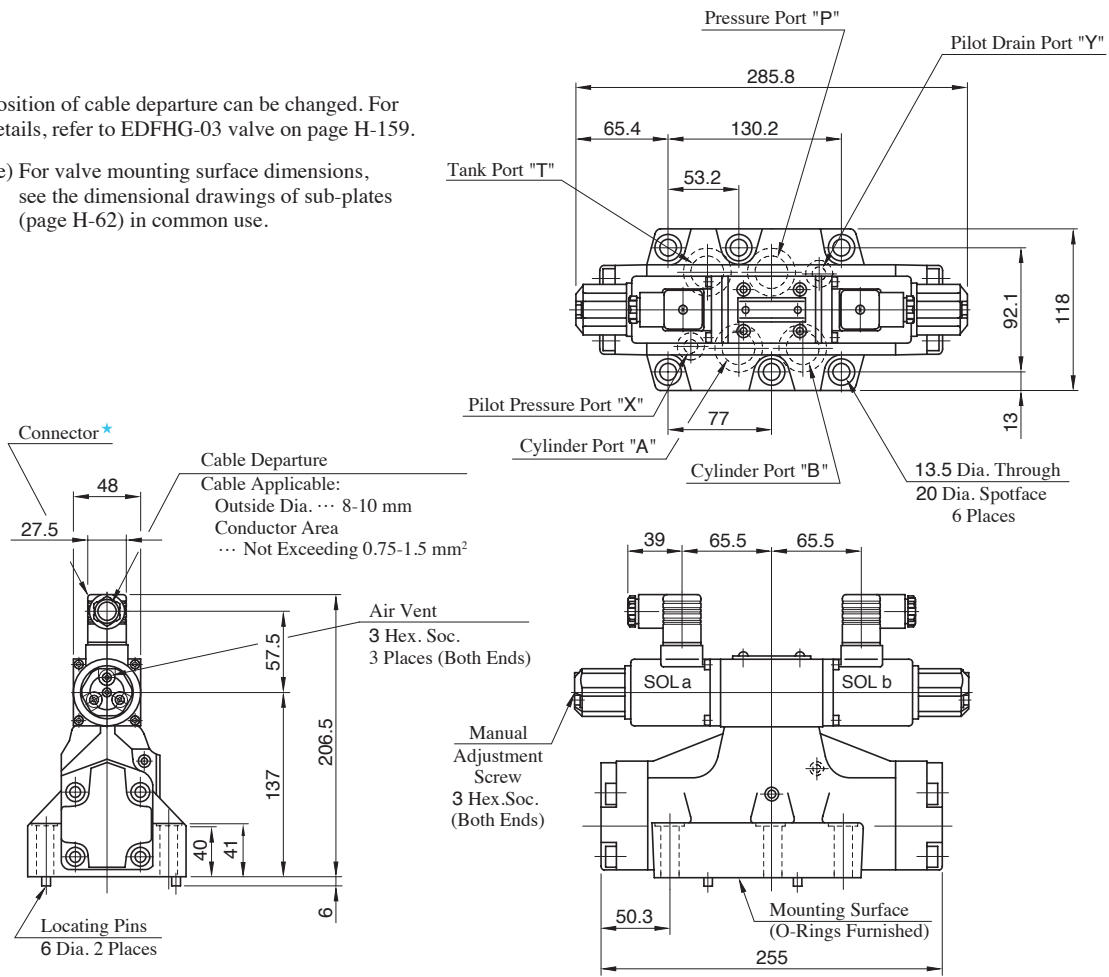

■ Interchangeability between Current and New Design

● Specifications and Characteristics

The input current and flow characteristics differ between the new and old models. Consult Yuken for details. Also, There is no change in specifications and characteristics between current and new design.

● Installation Interchangeability

There is an interchangeability in the mounting dimensions between current and new design, however, note that because of improvements made on the solenoids, the overall shapes and dimensions have been changed as shown below.

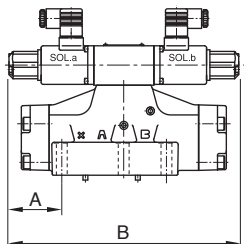

Model Numbers	A	B
(Current) EDFHG-03-100- * - * - * -30	117.9	287.8
(New) EDFHG-03-100- * - * - * -31	116.9	285.8
(Current) EDFHG-04-140- * - * - * -30	93.9	287.8
(New) EDFHG-04-140- * - * - * -31	92.9	285.8
(Current) EDFHG-06-280- * - * - * -30	66.4	287.8
(New) EDFHG-06-280- * - * - * -31	65.4	285.8

Input Current vs. Flow

Viscosity : 30 mm²/s

Valve Pres. Difference : P→A (B), B (A) →T 1 MPa

EDFHG-03

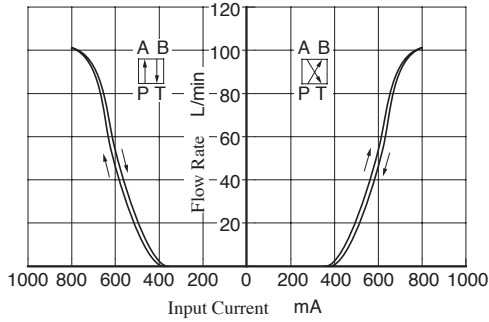

EDFHG-04

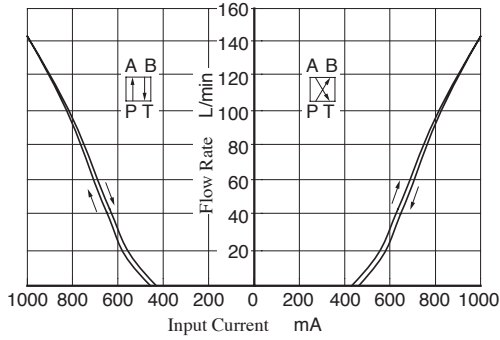

EDFHG-06

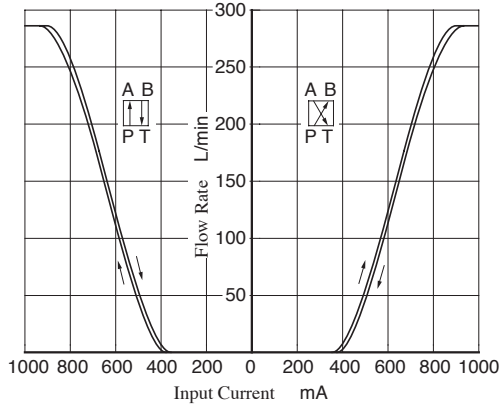

Valve Pressure Difference vs. Flow

Viscosity : 30 mm²/s

EDFHG-03

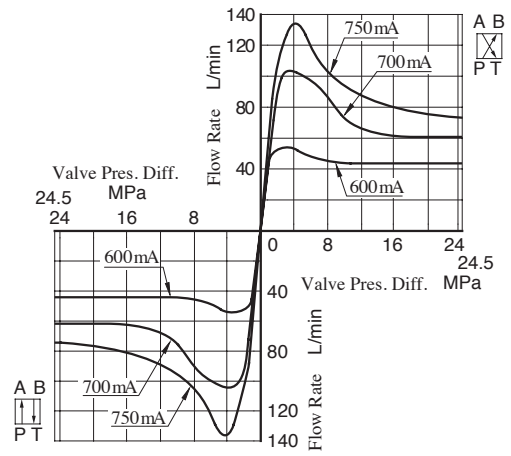

EDFHG-04

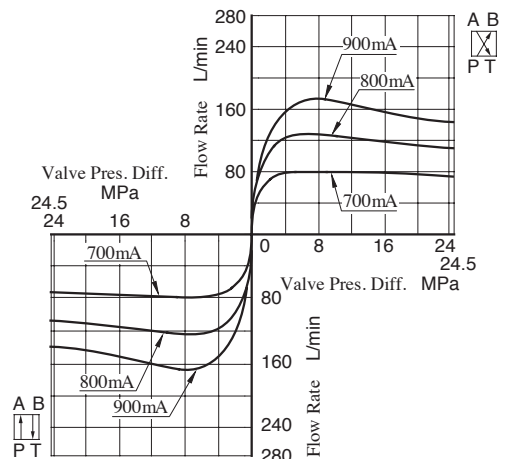

EDFHG-06

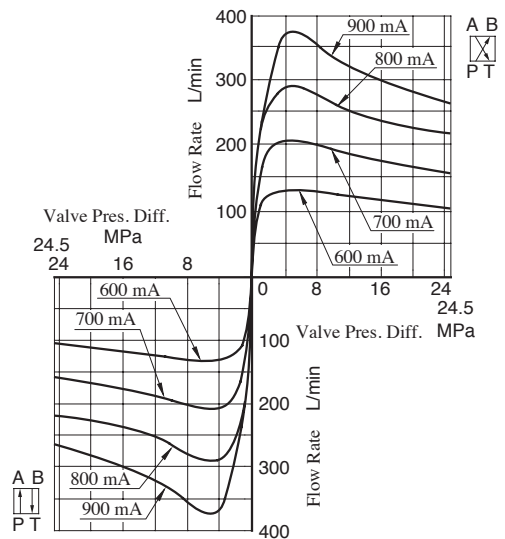

Frequency Response

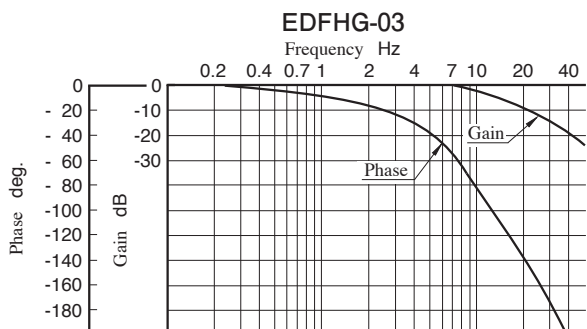

Model Number : EDFHG-03-100-3C2-E-31
Viscosity : 30 mm²/s
Pilot Pressure : 15.7 MPa
Travel of Spool : ±10% of Maximum Stroke

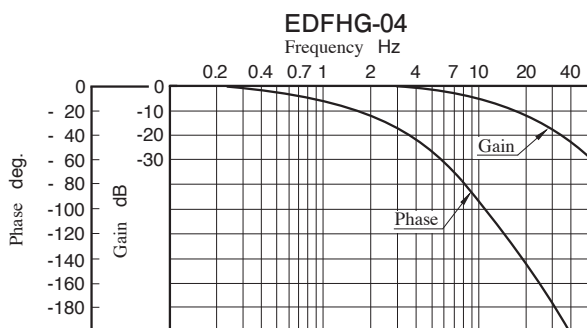

Model Number : EDFHG-04-140-3C2-E-31
Viscosity : 30 mm²/s
Pilot Pressure : 15.7 MPa
Travel of Spool : ±10% of Maximum Stroke

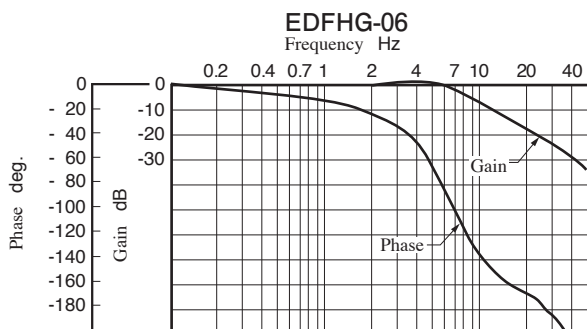

Model Number : EDFHG-06-280-3C2-E-31
Viscosity : 30 mm²/s
Pilot Pressure : 15.7 MPa
Travel of Spool : ±10% of Maximum Stroke

Step Response

These characteristics have been obtained by measuring on each valve. Therefore, they may vary according to a hydraulic circuit to be used.

Viscosity : 30 mm²/s
Supply Pressure : 15.7 MPa

