

EH Series-Hybrid Components

Proportional Electro-Hydraulic Controls

Type	Graphic Symbol	Max. Operating Pressure MPa	Maximum Flow L/min													Page
			1	2	3	5	10	20	30	50	100	200	300	500	1000	
Pilot Relief Valves		24.5	EHDG 01													H-4
Pressure Control Valves		SB1110: 24.5 SB1190: 7.0	SB1110 SB1190													H-11
Relief Valves		24.5	EHBG 03 06 10													H-15
Relieving and Reducing Valves		24.5	EHRBG 06 10													H-23
Flow Control (and Check) Valves		03: 20.6 06: 24.5	EHFG EHFCCG 03 06													H-29
Flow Control and Relief Valves		24.5	EHFBG 03 06 10													H-36
High Flow Series Flow Control and Relief Valves		24.5	EHFBG 03 06													H-45
Directional and Flow Control Valves		25	EHDFG 01 03													H-51
High Response Type Directional and Flow Control Valves		15.7	EHDFG 04 06													H-57
Direct Operated and High Response Type Directional and Flow Control Valves		35	ELDFG 01EH 03EH													H-62
Two Stage Type High Response Type Directional and Flow Control Valves		04EH:35 06EH:35 10EH 03EH:31.5 06EH:50	ELDFHG 03EH 04EH 06EH 10EH													H-68
Directional and Flow Control Valves (with Main Valve Feedback Control)		04EH:35 06EH:31.5	ECDFHG 04EH 06EH													H-80

Proportional Electro-Hydraulic Pilot Relief Valves

The valve can be used as a pilot valve of the proportional electro-hydraulic control valves.

The valve can also be used as a relief valve for the hydraulic system where a small flow rate and continuous pressure control are required.

Specifications

Model Numbers	EHDG-01 *	
Descriptions	EHDG-01 *	
Max. Operating Pres.	MPa	24.5
Max. Flow	L/min	2
Min. Flow	L/min	0.3
Pressure Adjustment Range	Refer to Model Number Designation	
Coil Resistance	10 Ω	
Hysteresis	3% (1%) ^{★1} or less	
Repeatability	1% ^{★2} or less	
Frequency Response	B: 10 (27) Hz ^{★1} C: 10 (27) Hz ^{★1} (-90 degree) H: 12 (27) Hz ^{★1}	
Supply Electric Power	24 V DC (21 to 28 V DC Included Ripple)	
Power Input (Max.)	28 W	
Input Signal Voltage	B: 6.9 MPa / 5 V DC C: 15.7 MPa / 5 V DC H: 24.5 MPa / 5 V DC	
Input Impedance	10 kΩ	
Alarm Signal Output (Open Collector)	Voltage: Max. 30 V DC Current: Max. 40 mA	
Pressure Signal Output	B: 5 V DC / 6.9 MPa C: 5 V DC / 15.7 MPa H: 5 V DC / 24.5 MPa	
Ambient Temperature	0 - 50°C (With Circulated Air)	
Mass	Refer to Page H-6	

- ★1. The value in parentheses is for the closed-loop type.
- ★2. The repeatability of the valve is obtained by having it tested independently on the conditions similar to its original testing.

Model Number Designation

EHD	G	-01	V	-B	-S	-1	-PN	T15	M10	-50
Series Number	Type of Mounting	Valve Size	Applicable Control	Pres. Adj. Range MPa (PSI)	Control Type	Safety Valve	P-Line Orifice	T-Line Orifice	P-B Line Orifice	Design Number
EHD : Proportional Electro-Hydraulic Pilot Relief Valve	G : Sub-Plate Mounting	01	None: For general use V : Vent Control of Relief Valve (Omit if not required)	B: 0.5 - 6.9 C: 1 - 15.7 H: 1.2 - 24.5	None: Open-Loop	None: Without Safety Valve 1 : With Safety Valve	PN : Without Orifice (Standard)	T15 T13 T11 ^{★2}	M10: Standard Orifice	50
					S: Open-Loop with Sensor L: Closed-Loop ^{★1}					

- ★1. For closed-loop models, specify applicable control code "V" even though the valve may not be used as vent control of relief valve.
- ★2. Standard of T-line Orifice.
Pres. Adj. Range B:T15, C:T13, H:T11.
- ★3. Phosphate ester type fluids are also supported. When phosphate ester type fluids are used, prefix "F-" to the model number because the special seals (fluororubber) are required to be used.

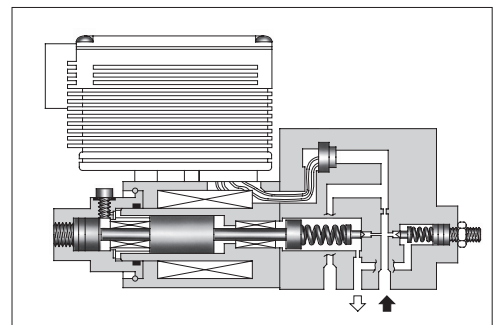
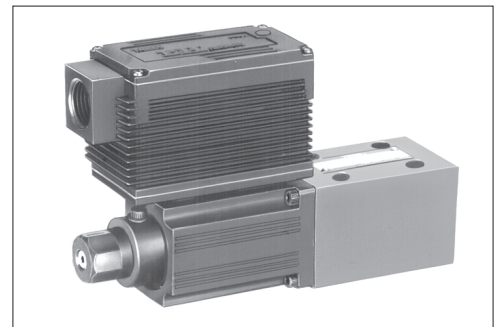

Graphic Symbols

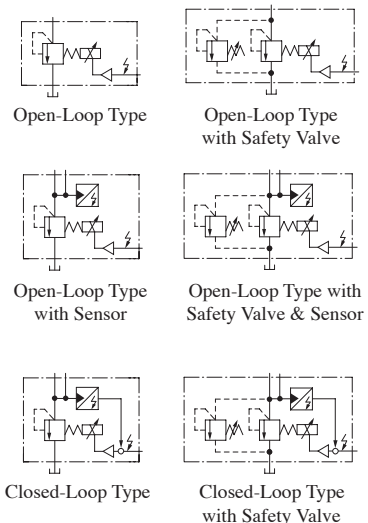

Accessories

● **Mounting Bolts**

Model Numbers	Socket Head Cap Screw
EHDG-01 * - * - * -PNT *	M5 × 45 L.....4 Pcs.
EHDG-01 * - * -S * - * -PNT * M10	M5 × 75 L.....4 Pcs.
EHDG-01V- * -L * - * -PNT * M10	

Sub-Plate

Sub-Plate Model Numbers	Thread Size Rc	Mass kg
DSGM-01-31	1/8	0.8
DSGM-01X-31	1/4	
DSGM-01Y-31	3/8	

● Sub-plates are available. Specify sub-plate model from the table left. When sub-plates are not used, the mounting surface should have a good machined finish. (L6/)

Instructions

● **Piping to the Reservoir**

The tank port should be connected directly to the reservoir with a back pressure of not more than 0.2 MPa. Be sure the end of pipe is dipped into the oil in the reservoir.

● **Vent Control**

When this valve is to be used as a relief valve or for other valve vent control purposes, use 6 mm ID, 300 mm or less long pipes for piping connections.

If pressure instability is encountered, provide a 1 - 1.5 mm diameter orifice for the relief or other valve vent port.

● **Circuit Pressure Control**

When circuit pressure is directly controlled by this valve, make sure that the trapped oil volume is exceeding 40 cm³.

● **Low Flow Rates**

The preselected pressure may become instable. To avoid such pressure instability, the flow rate should not be lower than 0.3 L/min.

● **Safety Valve Pressure Setting**

The safety valve pressure setting at the maximum flow rate is preset to a level that is 2 MPa higher than the pressure adjustment range upper limit. If the operating pressure upper limit is low or a different flow rate upper limit is used, make adjustment after calculating the safety valve pressure setting from the following equation:

$$\text{Pressure setting} = (\text{Operating pressure upper limit}) + (\text{Additional pressure indicated below})$$

To lower the pressure setting, turn the safety valve pressure adjustment screw anti-clockwise. After adjustment, be sure to tighten the lock nut.

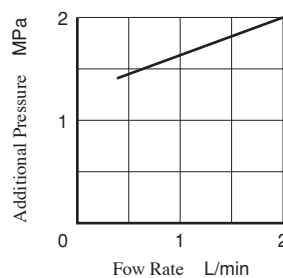

EHDG-01 *-* -S-1-PNT * M10-50 : Open-Loop Type with Sensor and Safety Valve
EHDG-01 *-* -L-1-PNT * M10-50 : Closed-Loop Type with Safety Valve

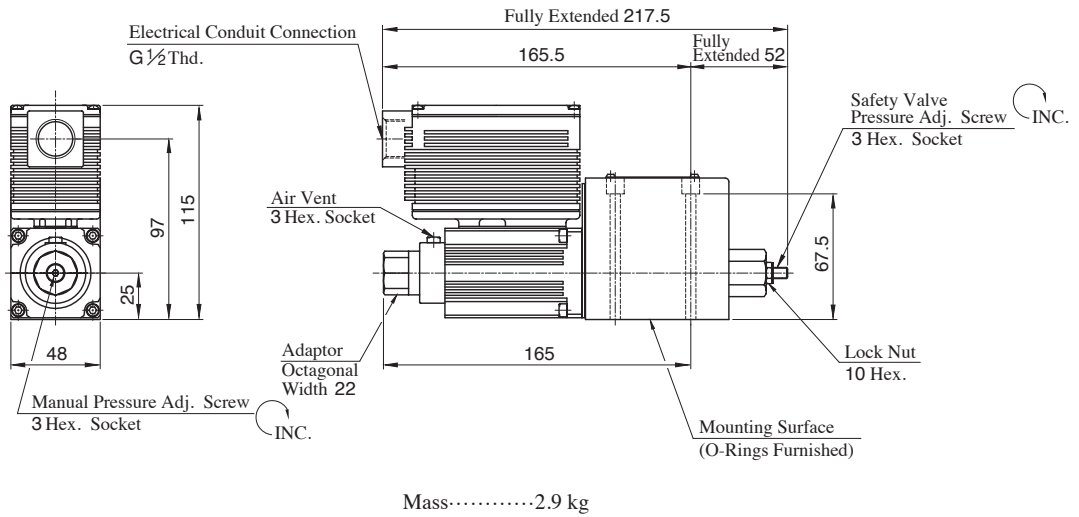
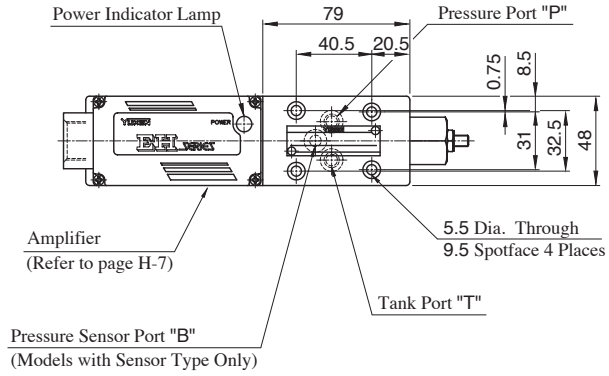

**EHDG-01 *-* -PNT * -50 :
Open-Loop Type**
**EHDG-01 *-* -1-PNT * -50 :
Open-Loop Type with Safety Valve**

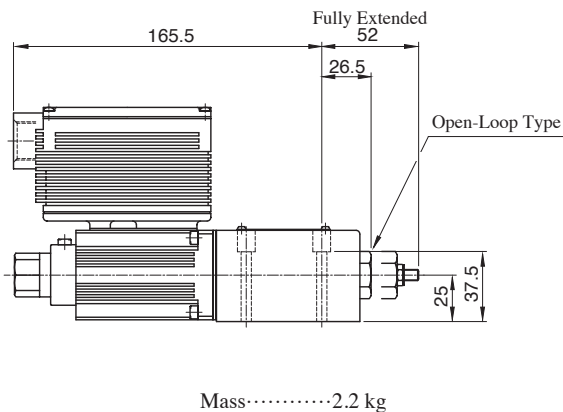

**EHDG-01 *-* -S-PNT * M10-50 :
Open-Loop Type with Sensor**
**EHDG-01 *-* -L-PNT * M10-50 :
Closed-Loop Type**

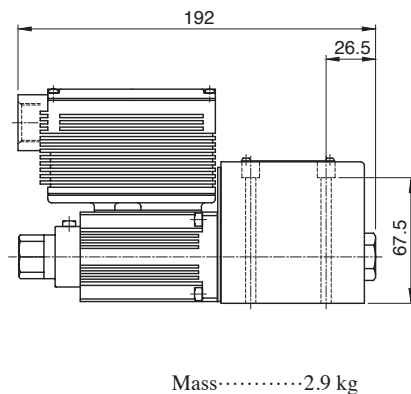

Detail of Amplifier

● **Connecting Terminal**

- Open-Loop Type

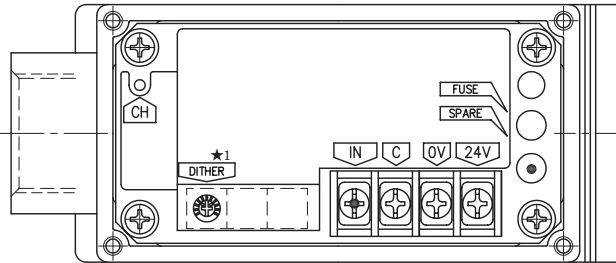

Terminal	Name
IN	Input Signal (+)
C	Input Signal (COM)
0 V	Power Supply
24V	
CH	Output Current Check (to C)

★1. DITHER/GAIN

Use as they are since they are factory-preset to the optimum position. (Do not touch them in normal condition.)

- Closed-Loop Type
- Open-Loop Type with Sensor

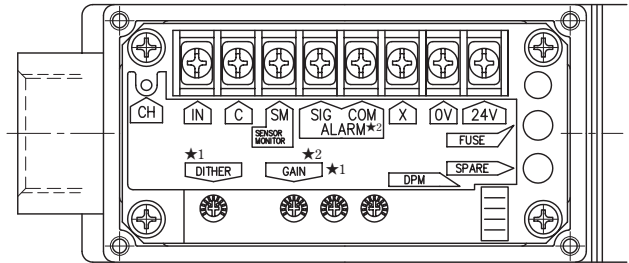

Terminal	Name	
IN	Input Signal (+)	
C	Input Signal (COM)	
SM	Sensor Monitor (to C)	
ALARM	SIG	Alarm Output ★2
	COM	
X	(Open)	
0 V	Power Supply	
24V		
CH	Output Current Check (to C)	

★2. GAIN/ALARM

GAIN adjusting volume is not available for open-loop type with sensor.

● **Circuit Schematic**

- Open-Loop Type
- Open-Loop Type with Sensor

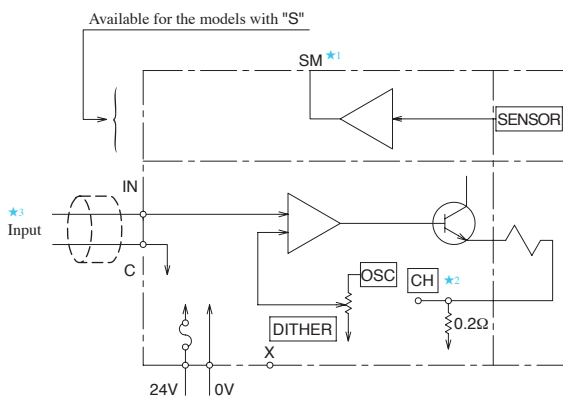

- Closed-Loop Type

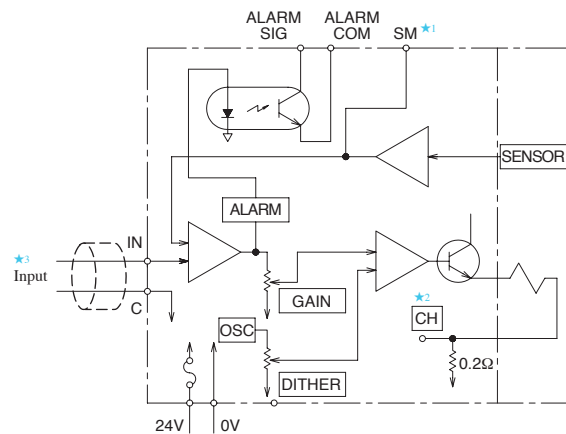

★1. For "SM" terminal, external instruments should have input impedance of more than 10 kΩ.

★2. For "CH" terminal, external instruments should have input impedance of more than 10 kΩ.

★3. Use shielded cable for "Input" connection. The ground of the shielded cable must be connected to input signal side.

Sub-Plates : DSGM-01, 01X, 01Y

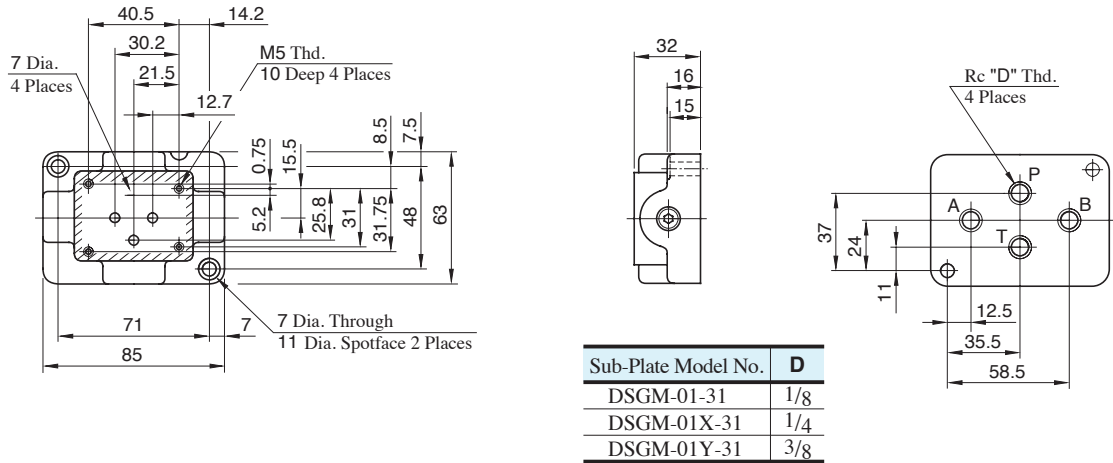

Min. Adjustment Pressure

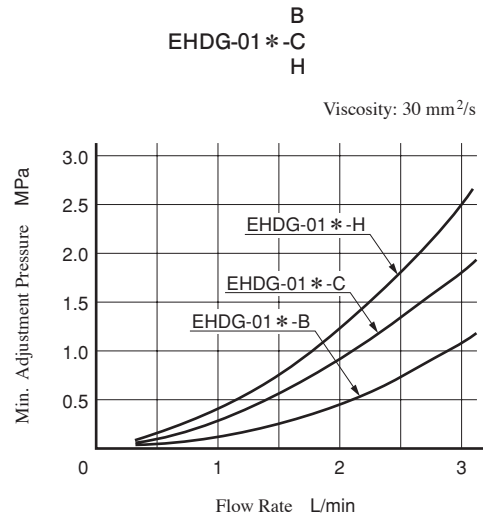

Input Signal Voltage vs. Pressure

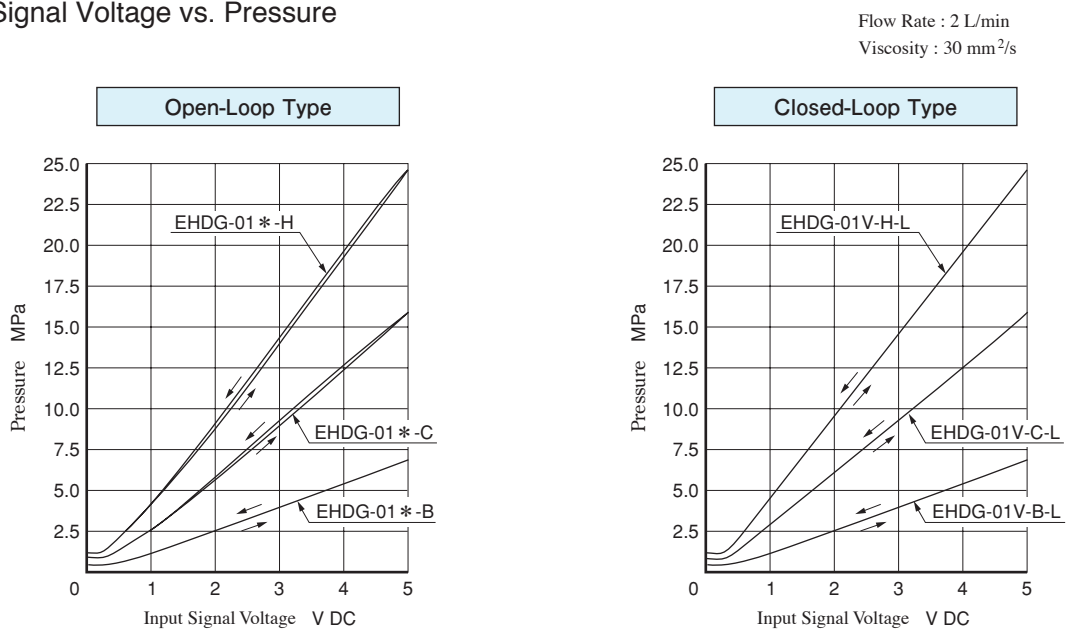

Flow Rate vs. Pressure

Viscosity : 30 mm²/s

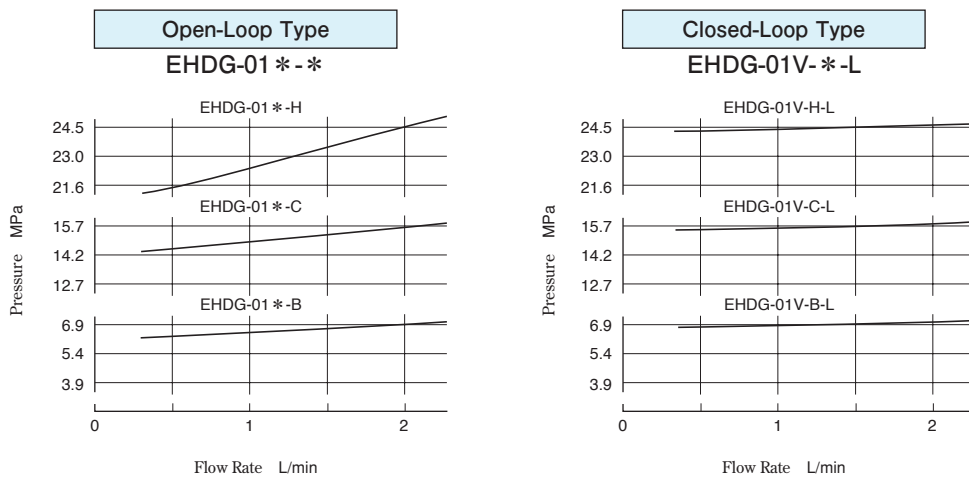

Viscosity vs. Pressure

Flow Rate : 2 L/min
Oil : ISO VG 46 Oil

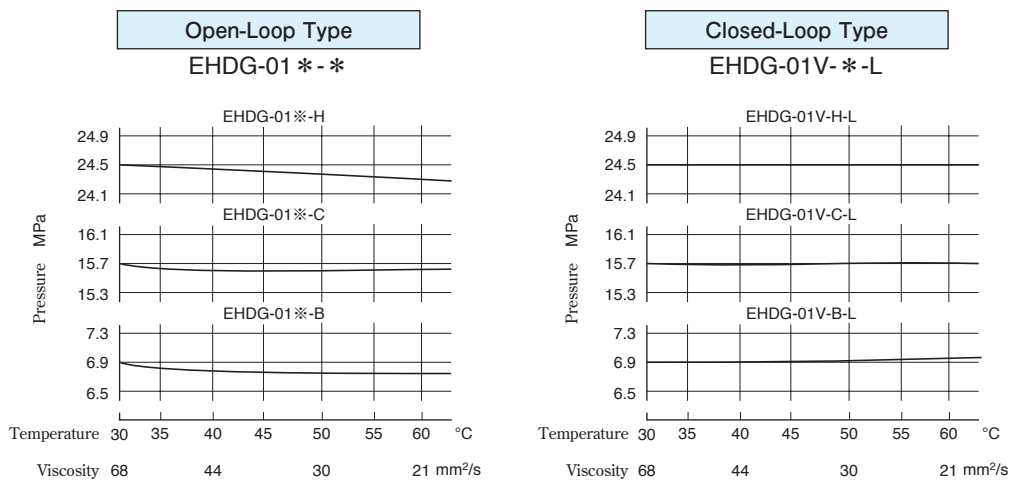

Frequency Response

Flow Rate : 2 L/min
Pressure : 7.8 ± 1.6 MPa
Trapped Oil Volume : 40 cm³
Viscosity : 30 mm²/s

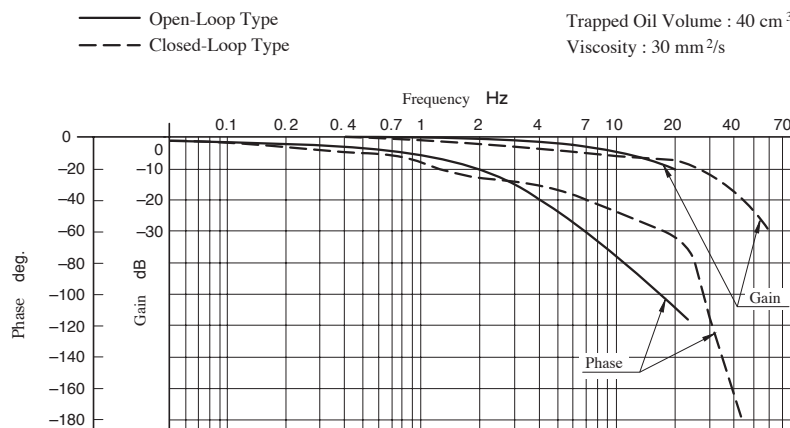

Step Response (Example)

The step responses below are those obtained when the valve itself is tested independently.
 The step responses may differ from them when the valve is used in combinations with other control valves.

Flow Rate : 2 L/min
 Trapped Oil Volume : 40 cm³
 Viscosity : 30 mm²/s

Open-Loop Type

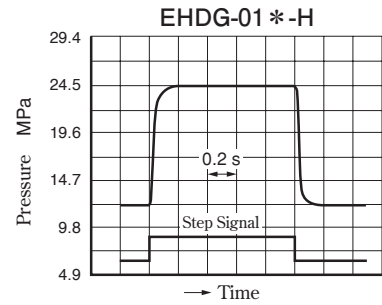
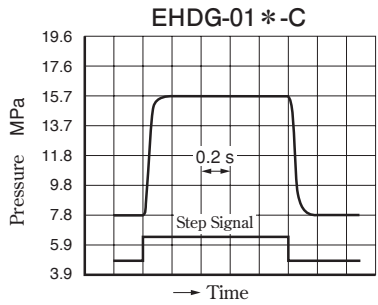
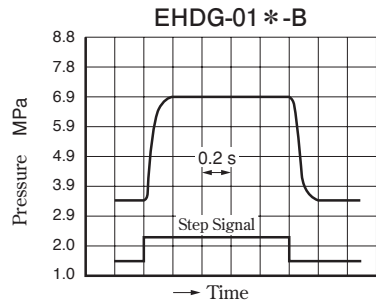

Closed-Loop Type

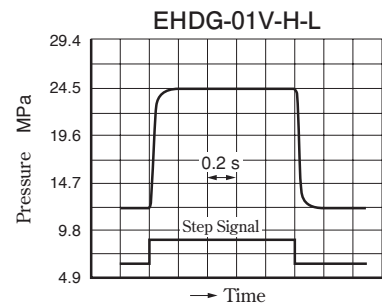
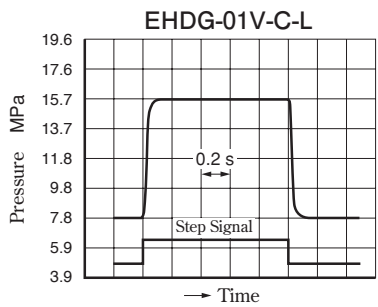
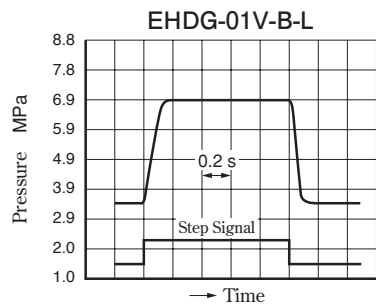

Proportional Electro-Hydraulic Pressure Control Valves

These are closed-loop type pressure control valves controlling the system pressure from low to high in proportion to the input voltage. The stable pressure control is possible even in a small flow rate.

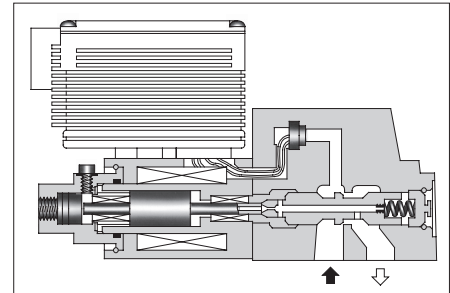
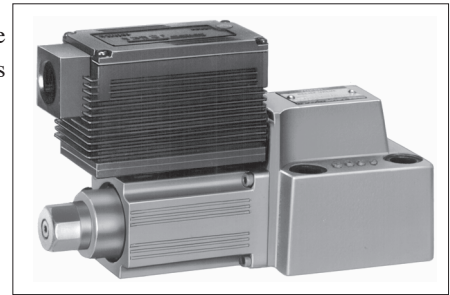

Specifications

Model Numbers		SB1110	SB1190
Descriptions			
Max. Operating Pres.	MPa	B: 6.9 H: 24.5	7.0
Max. Flow	L/min	30	70
Min. Flow	L/min	B: 0.5 H: 0.5 (at 0.2 - 6.9 MPa) 1.5 (at 6.9 - 15.7 MPa) 3.0 (at 15.7 - 24.5 MPa)	1
Pressure Adjustment Range	Refer to Model Number Designation		
Coil Resistance	10 Ω		
Hysteresis	1 % or less	1.5 % or less	
Repeatability	1 % ^{★1} or less		
Supply Electric Power	24 V DC (21 to 28 V DC Included Ripple)		
Power Input (Max.)	28 W		
Input Signal Voltage	B: 6.9 MPa / 5 V DC H: 24.5 MPa / 5 V DC	7.0 MPa / 5 V DC	
Input Impedance	10 kΩ		
Alarm Signal Output (Open Collector)	Voltage: Max. 30 V DC Current: Max. 40 mA		
Pressure Signal Output	B: 5 V DC / 6.9 MPa H: 5 V DC / 24.5 MPa	5 V DC / 7.0 MPa	
Ambient Temperature	0 - 50°C (With Circulated Air)		
Mass	3.3 kg	10.2 kg	

Graphic Symbol

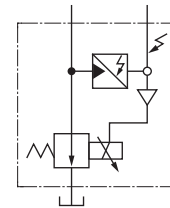

★1. The repeatability of the valve is obtained by having it tested independently on the conditions similar to its original testing.

Model Number Designation

SB1110	-B	-20
Series Number	Pres. Adj. Range MPa	Design Number
SB1110: Proportional Electro-Hydraulic Pressure Control Valve (3/8, Sub-Plate Mounting)	B: 0.2^{★1} - 6.9 H: 0.2^{★1} - 24.5	20
SB1190: Proportional Electro-Hydraulic Pressure Control Valve (3/4, Sub-Plate Mounting)	B: 0.2^{★1} - 7.0	10

★1. The minimum adjustable pressure is the value obtained at Max. Flow.

★2. Phosphate ester type fluids are also supported. When phosphate ester type fluids are used, prefix “F-” to the model number because the special seals (fluororubber) are required to be used.

Sub-Plate

Valve Model Numbers	Sub-Plate Model Numbers	Thread Size Rc	Mass kg
SB1110	BGM-03-20	3/8	2.4
	BGM-03X-20	1/2	3.1
SB1190	BGM-06-20	3/4	4.7
	BGM-06X-20	1	5.7

- Sub-plates are available. Specify sub-plate model from the table above.
When sub-plates are not used, the mounting surface should have a good machined finish. (⚙)

Accessories

● **Mounting Bolts**

Model Numbers	Socket Head Cap Screw
SB1110	M12 × 65 L.....4 Pcs.
SB1190	M16 × 100 L.....4 Pcs.

Instructions

- **Safety Valve**
As the function of safety valve has not been included in the valve itself, provide safety valve in the hydraulic circuit if required.
- **Piping to the Reservoir**
The tank port should be connected directly to the reservoir. Be sure the end of pipe is dipped into the oil in the reservoir.
- **Low Flow Rates**
The preselected pressure may become instable. To avoid such pressure instability, the flow rate should not be lower than minimum flow.

SB1110- *-20

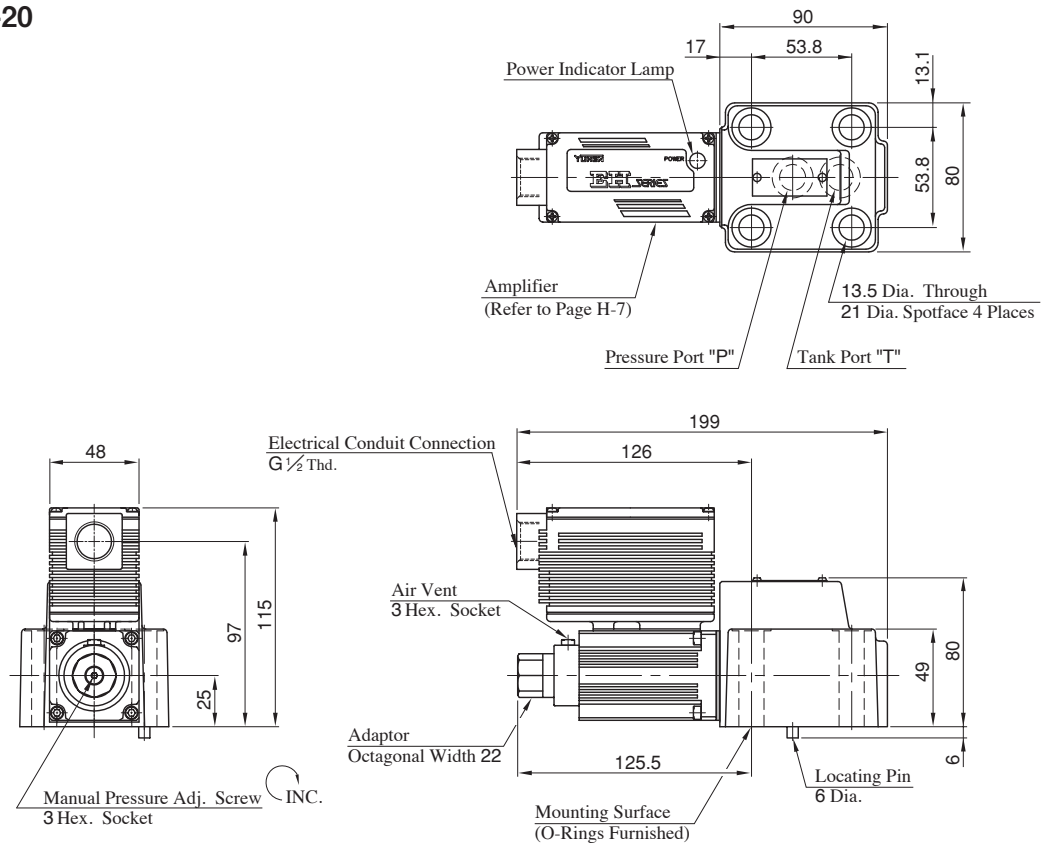

- Sub-plate is common to that of EBG-03. Refer to page H-18 for the dimensions of mounting surface.

SB1190-B-10

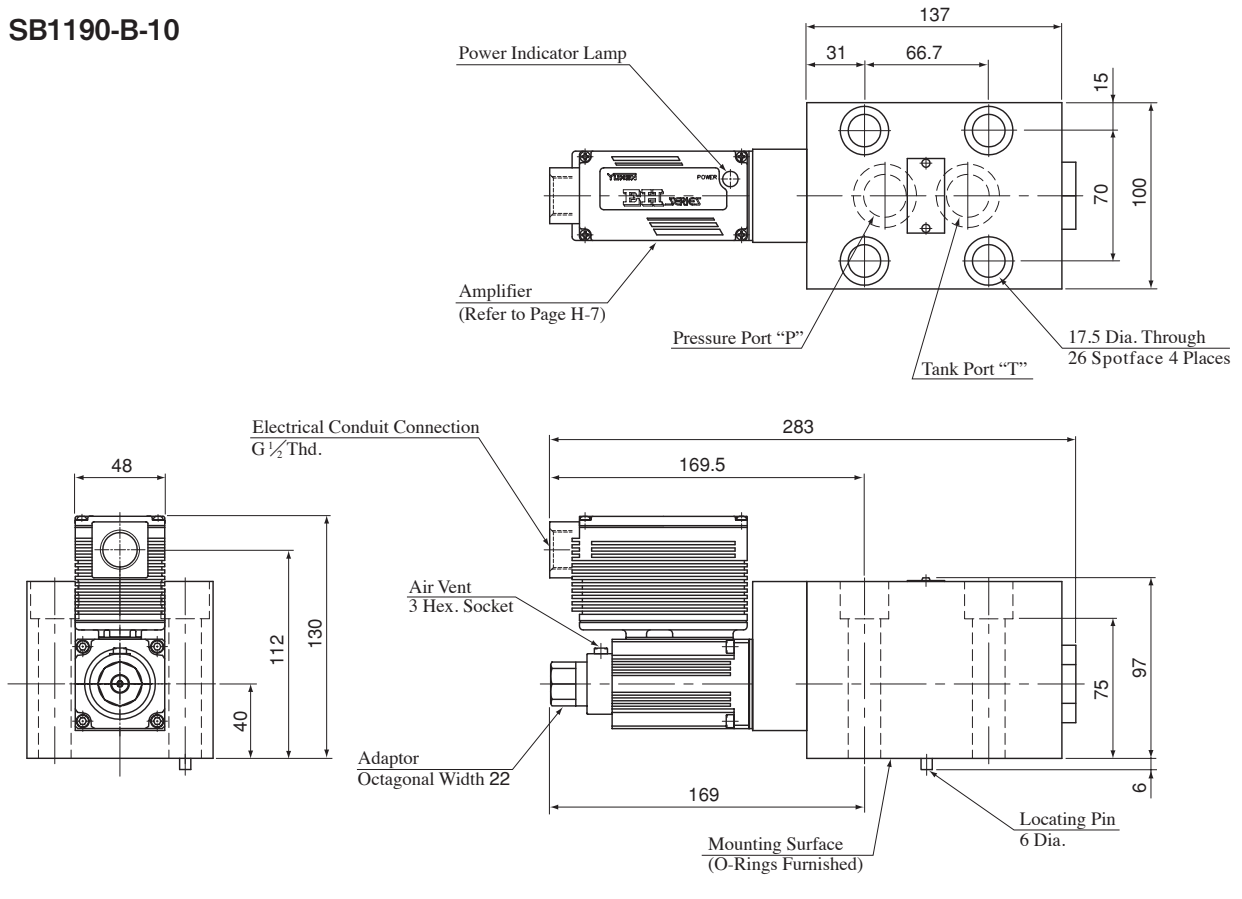

Min. Adjustment Pressure

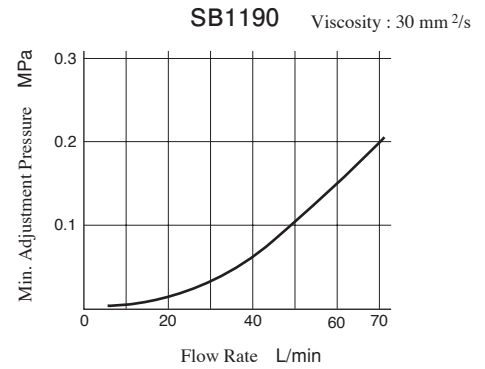
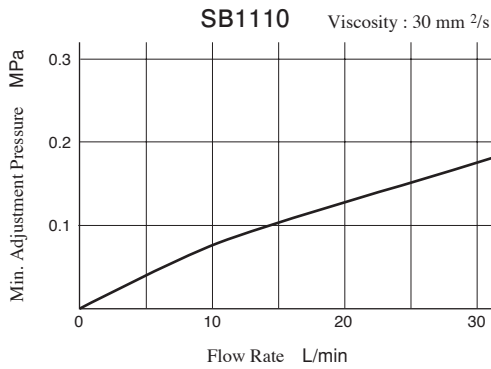

Input Signal Voltage vs. Pressure

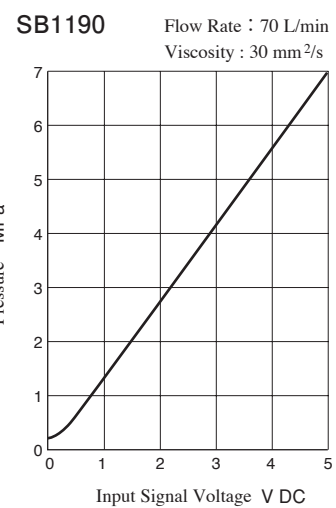
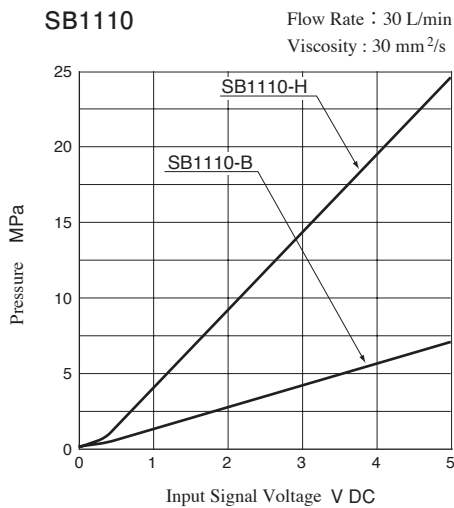

Flow Rate vs. Pressure

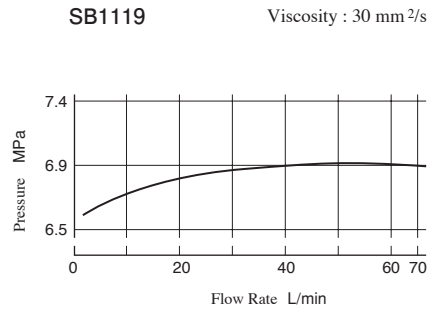
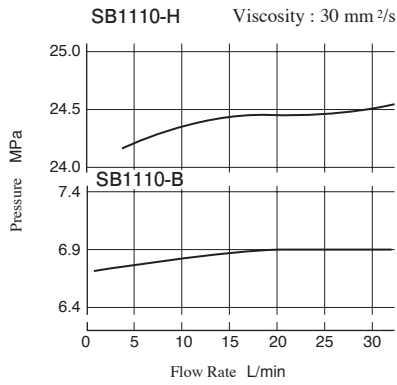

Viscosity vs. Pressure

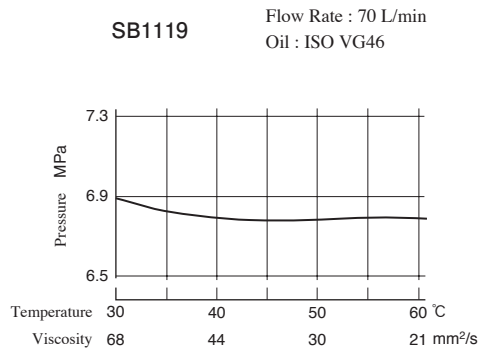
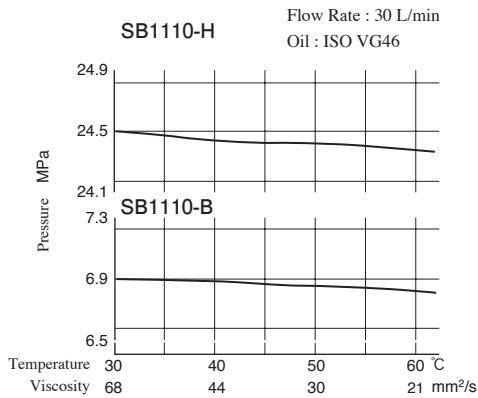

Frequency Response

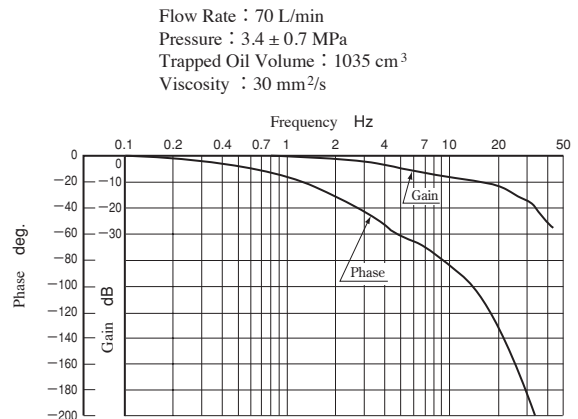
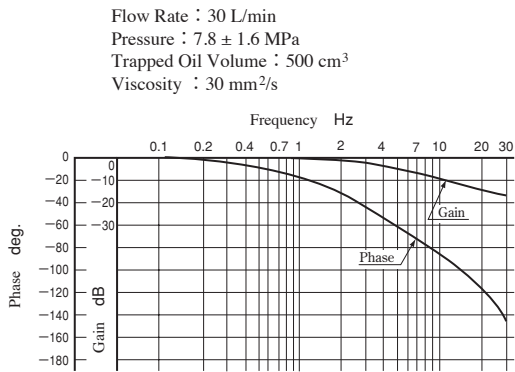

Step Response (Example)

The step responses below are those obtained when the valve itself is tested independently.
The step responses may differ from them when the valve is used in combination with other control valves.

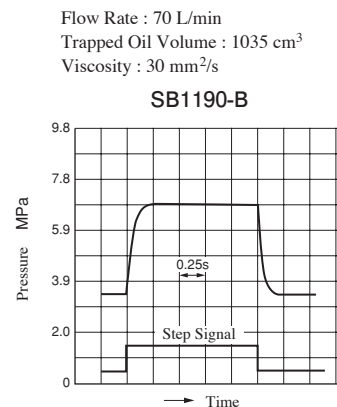
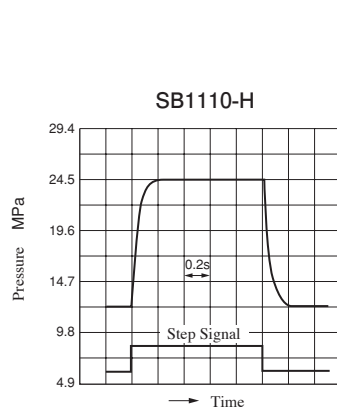
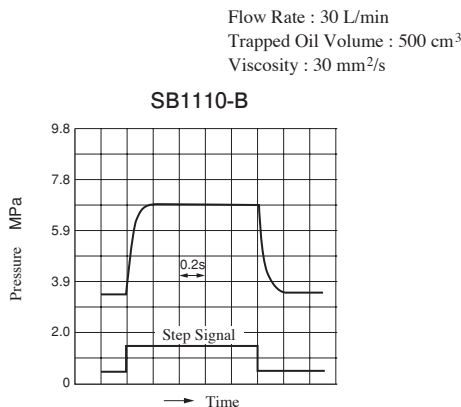

Proportional Electro-Hydraulic Relief Valves

These valves, consist of a small size but high performance EH series electro-hydraulic proportional pilot relief valve and a low noise type relief valve. The valves control the system pressure proportionally through a controlled input voltage.

Specifications

Model Numbers	EHBG-03	EHBG-06	EHBG-10
Descriptions			
Max. Operating Pres.	24.5 MPa		
Max. Flow	100 L/min	200 L/min	400 L/min
Min. Flow	3 L/min	3 L/min	3 L/min
Pressure Adjustment Range	Refer to Model Number Designation		
Coil Resistance	10 Ω		
Hysteresis	2% (1%) ^{★1} or less		
Repeatability	1% ^{★2} or less		
Frequency Response	C : 10 (22) Hz ^{★1} H : 10 (25) Hz ^{★1} (-90 degree)	C : 11 (22) Hz ^{★1} H : 13 (24.5) Hz ^{★1} (-90 degree)	C : 7 (10.5) Hz ^{★1} H : 6 (14) Hz ^{★1} (-90 degree)
Supply Electric Power	24 V DC (21 to 28 V DC Included Ripple)		
Power Input (Max.)	28 W		
Input Signal Voltage	C : 15.7 MPa / 5 V DC H : 24.5 MPa / 5 V DC (At Max. Flow)		
Input Impedance	10 k Ω		
Alarm Signal Output (Open Collector)	Voltage: Max. 30 V DC Current: Max. 40 mA		
Pressure Signal Output	C : 5 V DC / 15.7 MPa H : 5 V DC / 24.5 MPa		
Ambient Temperature	0 - 50°C (With Circulated Air)		
Mass	Refer to Page H-17		

- ★1. The value in parentheses is for the closed-loop type.
- ★2. The repeatability of the valve is obtained by having it tested independently on the conditions similar to its original testing.

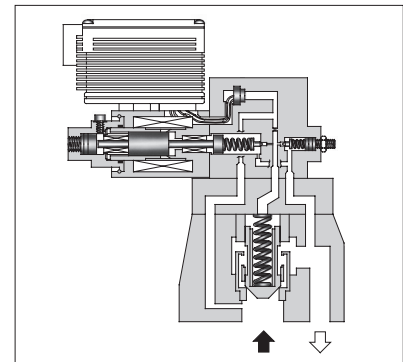
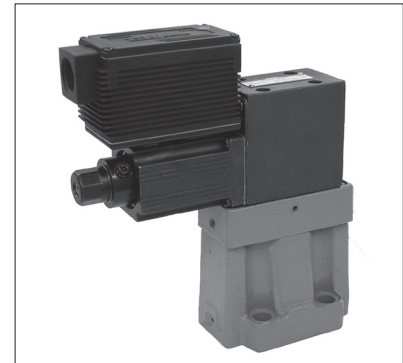

Graphic Symbols

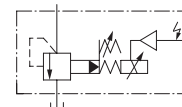

Open-Loop Type

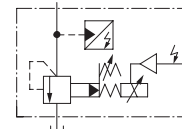

Open-Loop Type with Sensor

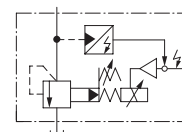

Closed-Loop Type

Model Number Designation

EHB	G	-03	-C	-S	-50
Series Number	Type of Mounting	Valve Size	Pres. Adj. Range MPa	Control Type	Design Number
EHB : Proportional Electro-Hydraulic Relief Valve	G : Sub-Plate Mounting	03	C : ★-15.7 H : ★-24.5	None: Open-Loop	50
		06		S : Open-Loop with Sensor	50
		10		L : Closed-Loop	50

Note1: For the lower limits of the adjustable pressure shown with an asterisk (★), see the minimum adjustable pressure characteristics on page H-19.
 Note2: Phosphate ester type fluids are also supported. When phosphate ester type fluids are used, prefix "F-" to the model number because the special seals (fluororubber) are required to be used.

Accessories

● **Mounting Bolts**

Model Numbers	Socket Head Cap Screw
EHBG-03	M12 × 40 L.....4 Pcs.
EHBG-06	M16 × 50 L.....4 Pcs.
EHBG-10	M20 × 60 L.....4 Pcs.

Sub-Plate

Valve Model Numbers	Sub-Plate Model Numbers	Thread Size Rc	Mass kg
EHBG-03	BGM-03-20	3/8	2.4
	BGM-03X-20	1/2	3.1
EHBG-06	BGM-06-20	3/4	4.7
	BGM-06X-20	1	5.7
EHBG-10	BGM-10-20	1 1/4	8.4
	BGM-10X-20	1 1/2	10.3

● Sub-plates are available. Specify sub-plate model from the table left. When sub-plates are not used, the mounting surface should have a good machined finish. (1/5)

Instructions

● **Piping to the Reservoir**

The tank port should be connected directly to the reservoir. Be sure the end of pipe is dipped into the oil in the reservoir.

● **Low Flow Rates**

A flow rate of 3 L/min or higher should be used to avoid preselected pressure instability.

● **Safety Valve**

At shipment, the pressure of safety valves is set to the upper limits of the adjustable pressure ranges plus the extra as shown below.

Additional Pressures for Safety Valves at Shipment

Model No.	Additional Pressures at Shipment MPa
EHBG-03	1.5 (at 50 L/min)
EHBG-06	1.5 (at 100 L/min)
EHBG-10	2.5 (at 200 L/min)

If the operating pressure upper limit is low or a different flow rate upper limit is used, make adjustment after calculating the safety valve pressure setting from the following equation;

$$\text{Pressure Setting} = (\text{Operating Pressure Upper Limit}) + (\text{Additional Pressure Indicated Below})$$

To lower the pressure setting, turn the safety valve pressure adjustment screw anti-clockwise. After adjustment, be sure to tighten the lock nut.

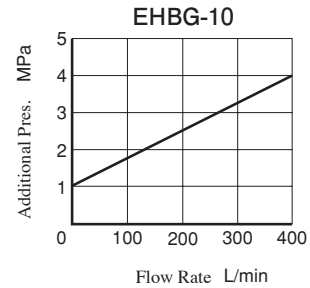
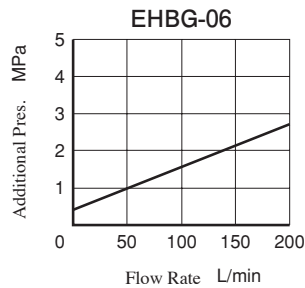
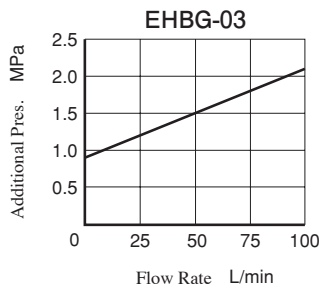

- EHBG-03/06/10-* -50 : Open-Loop Type
- EHBG-03/06/10-* -S-50 : Open-Loop Type with Sensor
- EHBG-03/06/10-* -L-50 : Closed-Loop Type

Model Numbers	Mass kg	
	Open-Loop Type	Open-Loop Type with Sensor Closed-Loop Type
EHBG-03	5.6	6.3
EHBG-06	6.8	7.5
EHBG-10	10.5	11.2

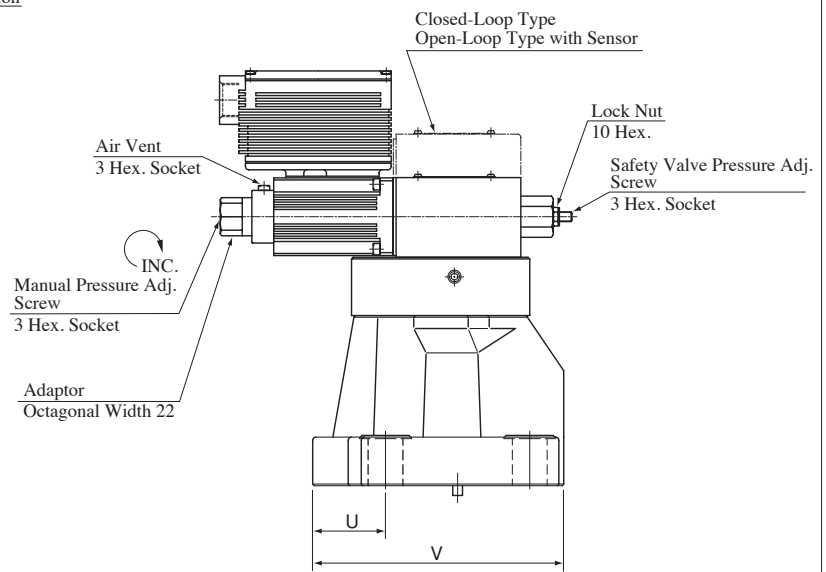
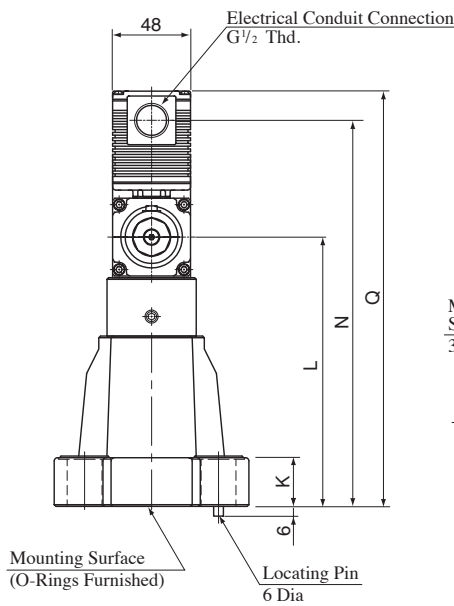
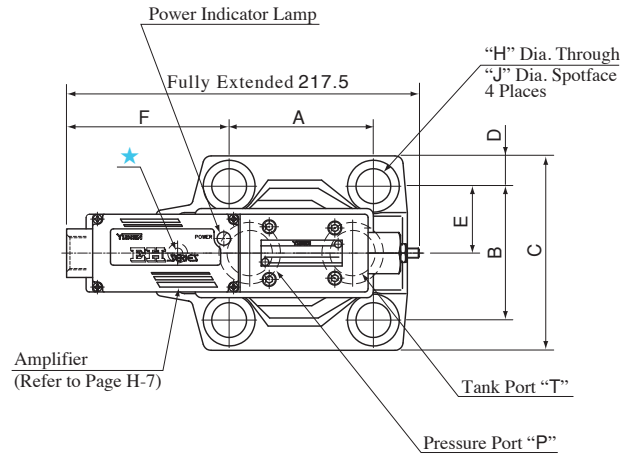

★ This port connection is not used.

Model No.	A	B	C	D	E	F	H	J	K
EHBG-03	53.8	53.8	76	11.1	26.9	119.1	13.5	21	21.5
EHBG-06	66.7	70	98	14	35	121	17.5	26	26
EHBG-10	88.9	82.6	120	18.7	41.3	102.5	21.5	32	33.5

Model No.	L	N	Q	U	V	Mounting Surface
EHBG-03	130	202	220	26.1	106	ISO 6264-AR-06-2-A
EHBG-06	130	202	220	36	122	ISO 6264-AS-08-2-A
EHBG-10	166	238	256	45	155	ISO 6264-AT-10-2-A

Sub-Plates
BGM-03, 03X
06, 06X
10, 10X

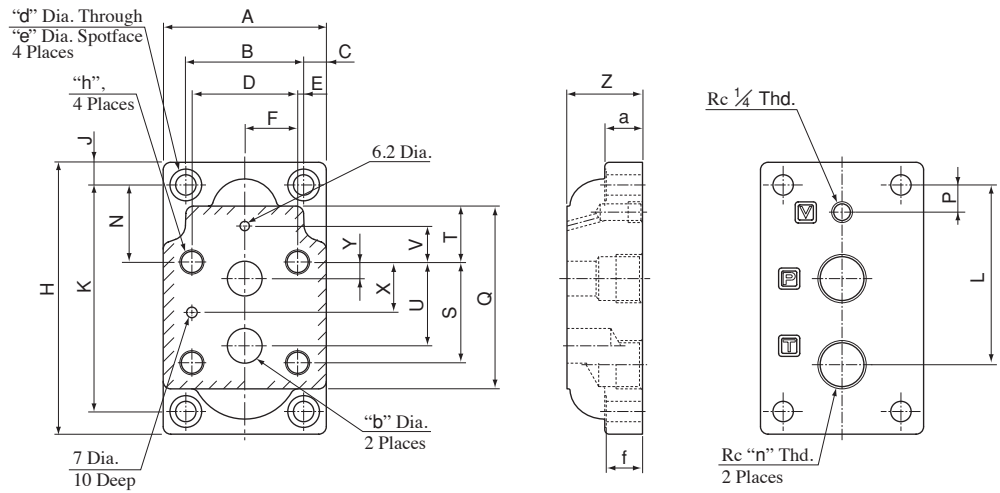

Model No.	A	B	C	D	E	F	H	J	K	L	N	P	Q	S
BGM-03	86	60	13	53.8	3.1	26.9	149	13	123	86	32	26	97	53.8
BGM-03X										95		21		
BGM-06	108	78	15	70	4	35	180	15	150	106.5	51	27.2	121	66.7
BGM-06X										119		18		
BGM-10	126	94	16	82.6	5.7	41.3	227	16	195	138.2	62	30.2	154	88.9
BGM-10X										158		17		

Model No.	T	U	V	X	Y	Z	a	b	d	e	f	h	n
BGM-03	19	47.4	0	22	22	32	20	14.5	11	17.5	19	M12 Thd. 20 Deep	3/8
BGM-03X						40							1/2
BGM-06	37	55.5	23.8	33.4	11	40	25	23	13.5	21	24	M16 Thd. 25 Deep	3/4
BGM-06X						50							1
BGM-10	42	76.2	31.8	44.5	12.7	50	32	28	17.5	26	31	M20 Thd. 28 Deep	1 1/4
BGM-10X						63							1 1/2

Min. Adjustment Pressure

— Open-Loop Type
 - - - Closed-Loop Type

Viscosity : 30 mm²/s

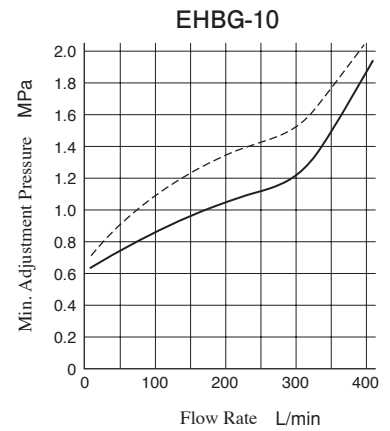
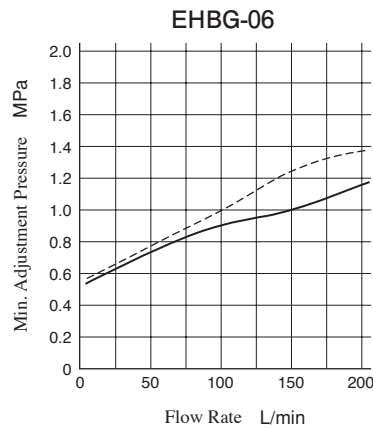
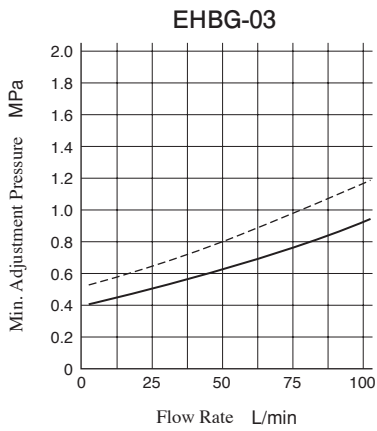

Input Signal Voltage vs. Pressure

Open-Loop Type

Viscosity : 30 mm²/s

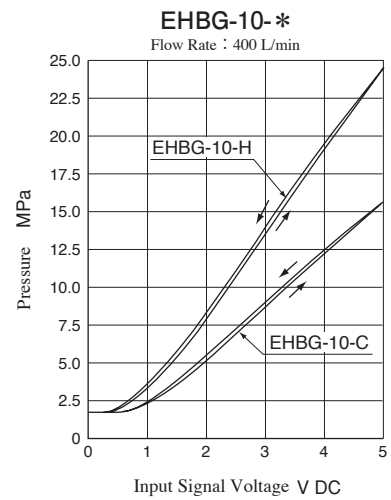
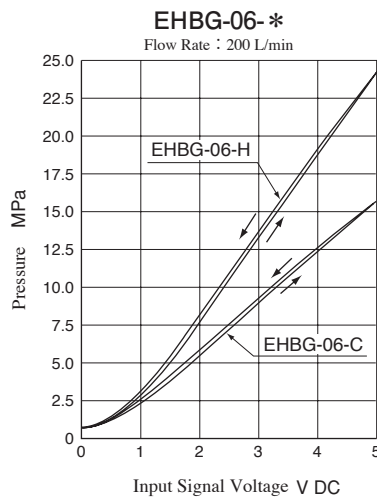
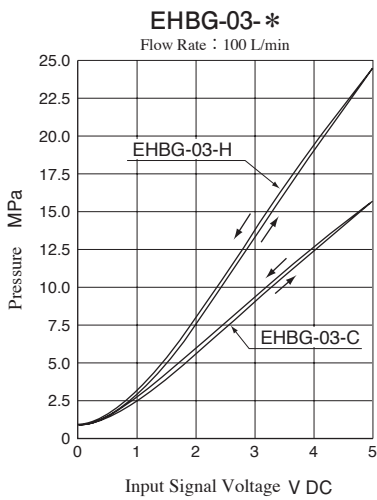

Closed-Loop Type

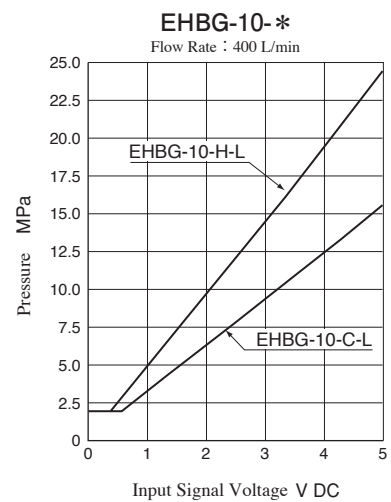
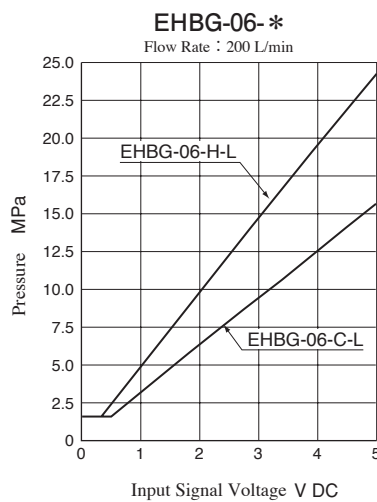
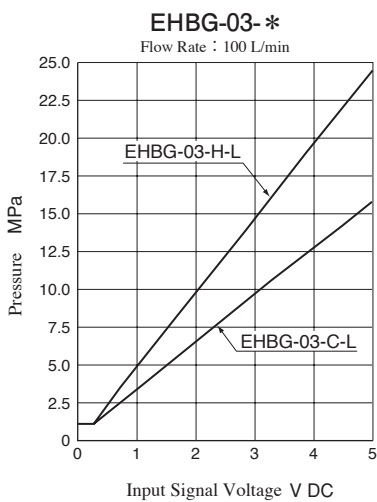

Flow Rate vs. Pressure

Viscosity : 30 mm²/s

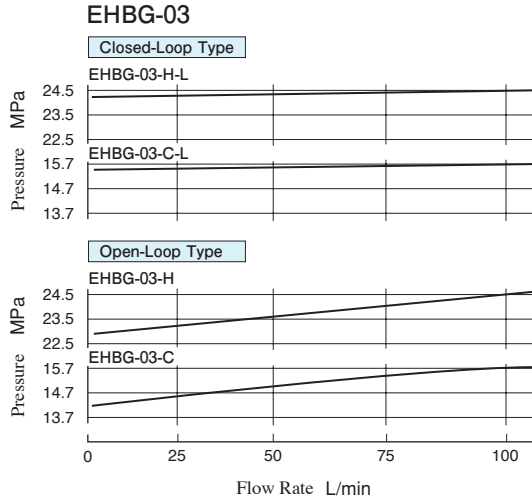

Viscosity vs. Pressure

Oil : ISO VG46 Oil

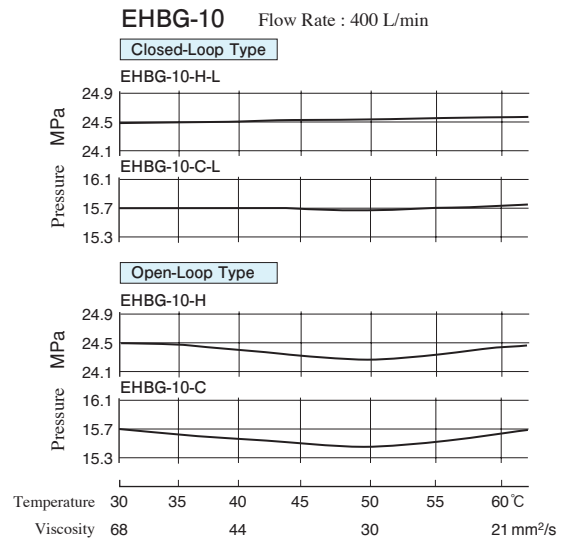
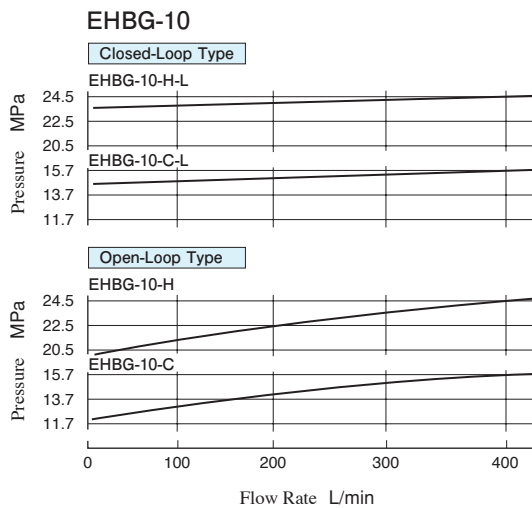
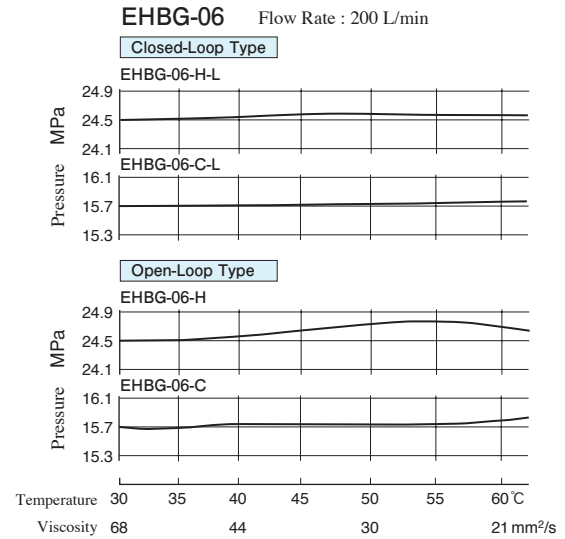
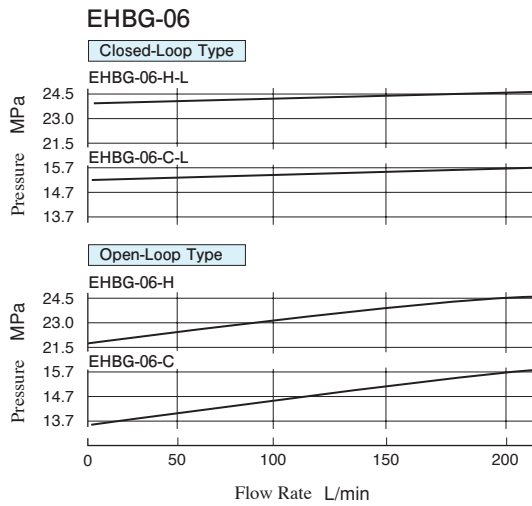
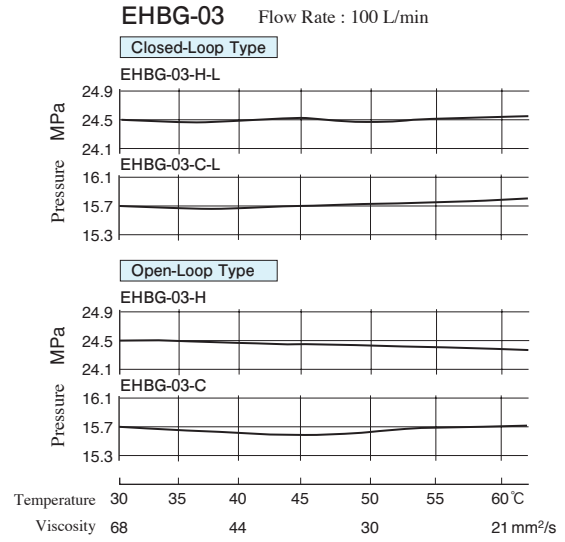

Step Response (Example)

The step responses below are those obtained when the valve itself is tested independently.

Trapped Oil Volume : 1 L
Viscosity : 30 mm²/s

The step responses may differ from them when the valve is used in combinations with other control valves.

Open-Loop Type

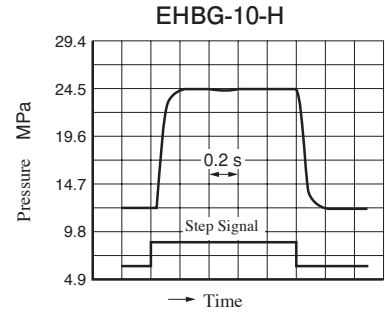
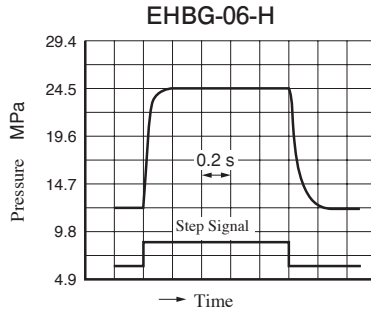
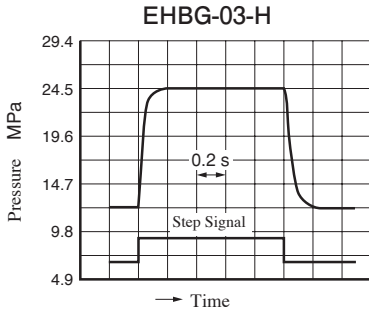
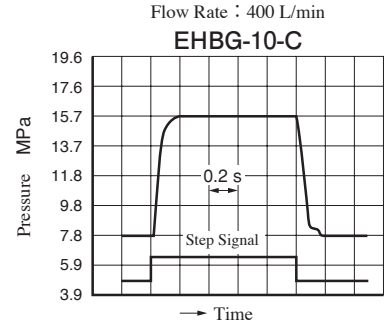
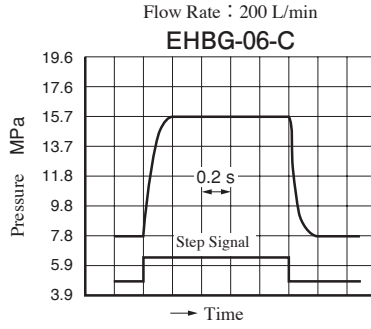
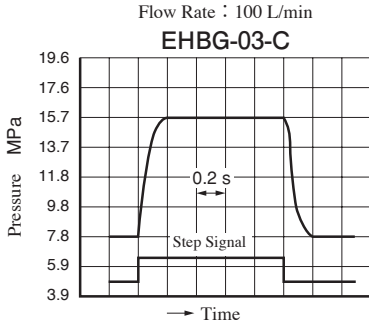

Closed-Loop Type

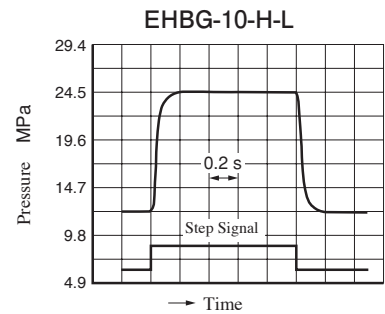
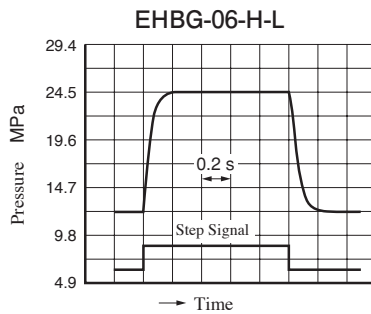
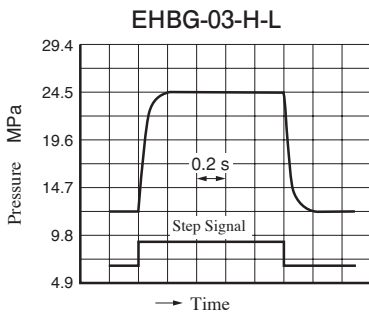
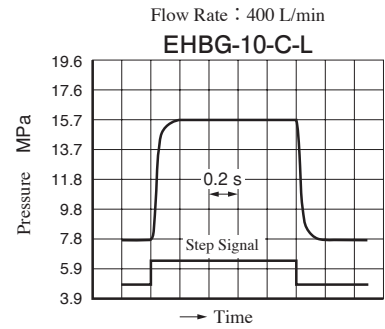
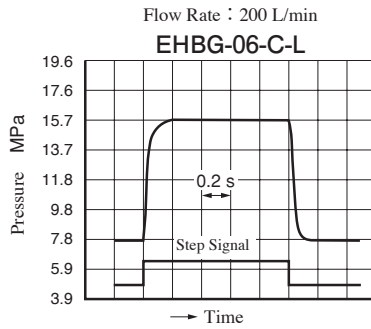
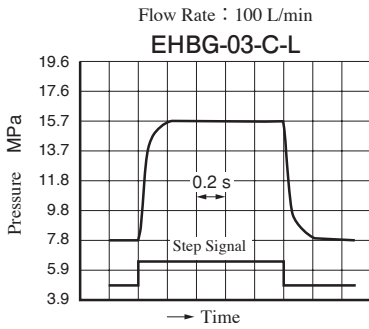

Frequency Response

— Open-Loop Type
 - - - Closed-Loop Type

Trapped Oil Volume : 1 L
 Viscosity : 30 mm²/s

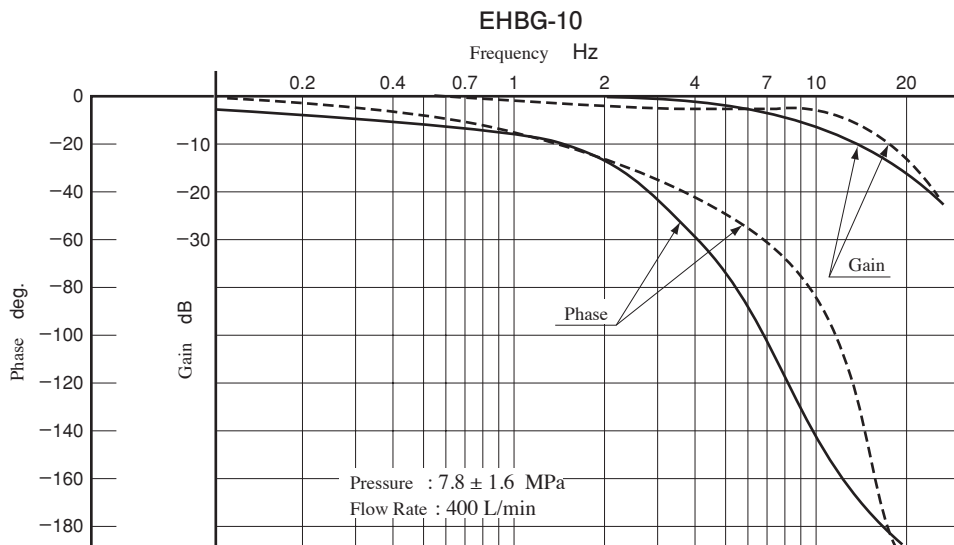
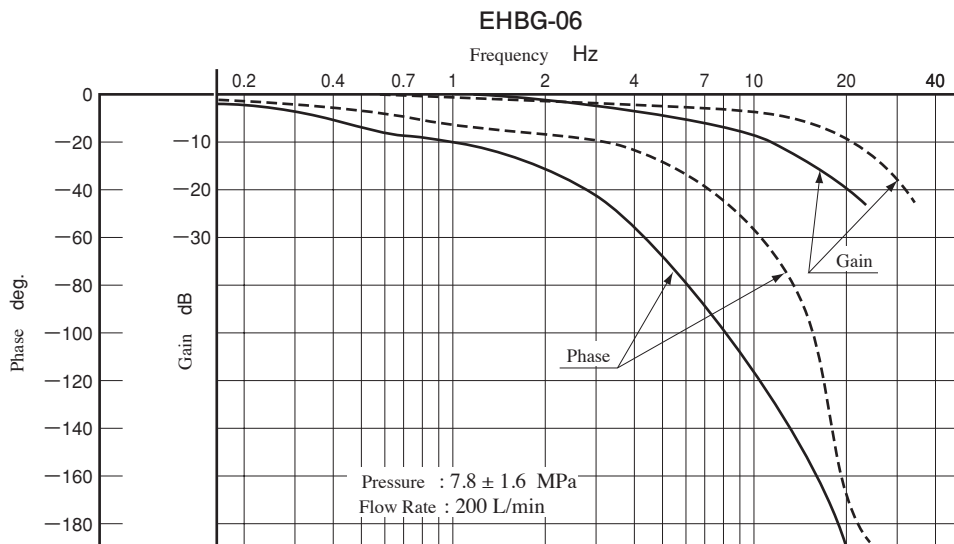
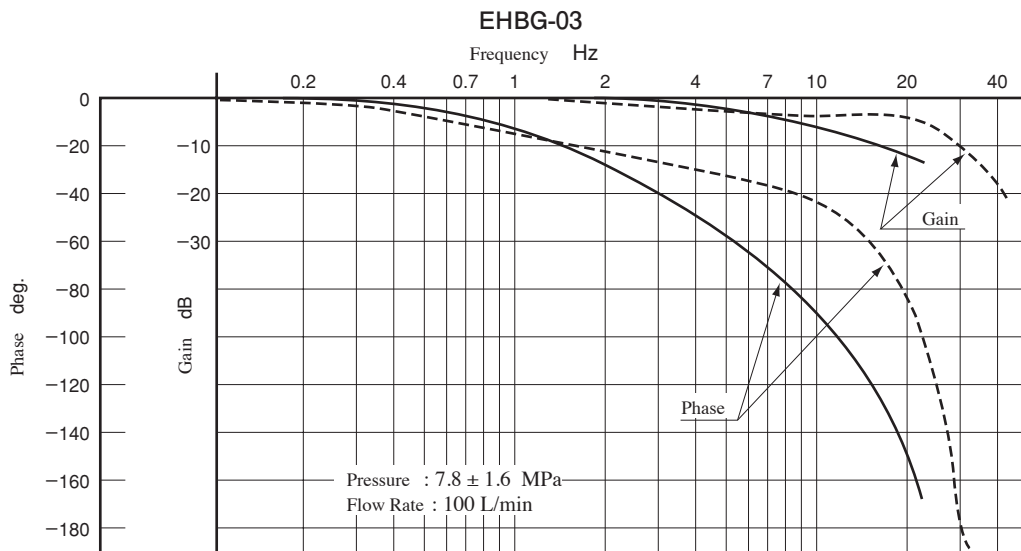

Proportional Electro-Hydraulic Relieving and Reducing Valves

These valves consist of a small size but high performance electro-hydraulic proportional pilot relief valve and reducing valve with relief function. The valves control the system pressure proportionally through a controlled input voltage. Moreover, a good response speed in reducing the pressure even at a large load capacity can be obtained with the relief function of the valves.

Specifications

Model Numbers	EHRBG-06	EHRBG-10
Descriptions		
Max. Operating Pres. MPa	24.5	
Max. Flow L/min	100	250
Max. Relieving Flow L/min	35 ^{*1}	15 ^{*1}
Pressure Adjustment Range	Refer to Model Number Designation	
Coil Resistance	10 Ω	
Hysteresis	3% or less	
Repeatability	1% ^{*2} or less	
Frequency Response	B: 4 Hz C: 3 Hz (-90 degree) H: 3 Hz	
Supply Electric Power	24 V DC (21 to 28 V DC Included Ripple)	
Power Input (Max.)	28 W	
Input Signal Voltage	B: 6.9 MPa / 5 V DC C: 13.7 MPa / 5 V DC H: 20.6 MPa / 5 V DC (at Flow Rate Zero)	
Input Impedance	10 k Ω	
Pressure Signal Output	B: 5 V DC / 6.9 MPa C: 5 V DC / 13.7 MPa H: 5 V DC / 20.6 MPa	
Ambient Temperature	0 - 50°C (With Circulated Air)	
Mass	Refer to Pages H-24 & H-25	

- ★ 1. The figures shown are those obtained where the differential pressure between the secondary pressure port and tank port is 13.7 MPa.
- ★ 2. The repeatability of the valve is obtained by having it tested independently on the conditions similar to its original testing.

Model Number Designation

EHRB	G	-06	-C	-S	-50
Series Number	Type of Mounting	Valve Size	Pres. Adj. Range MPa	Control Type	Design Number
EHRB: Proportional Electro-Hydraulic Relieving & Reducing Valve	G: Sub-Plate Mounting	06	B: 0.8 - 6.9 C: 1.2 - 13.7 H: 1.5 - 20.6	None: Open-Loop	50
		10	B: 0.9 - 6.9 C: 1.2 - 13.7 H: 1.5 - 20.6	S: Open-Loop with Sensor	

- ★ Phosphate ester type fluids are also supported. When phosphate ester type fluids are used, prefix "F-" to the model number because the special seals (fluororubber) are required to be used.

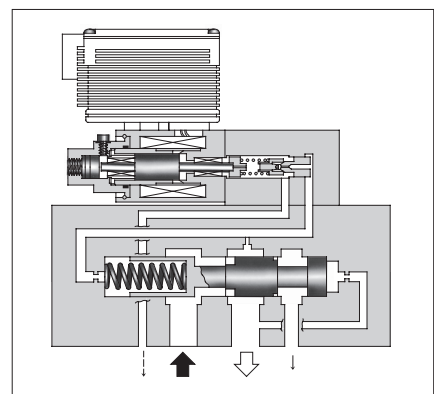
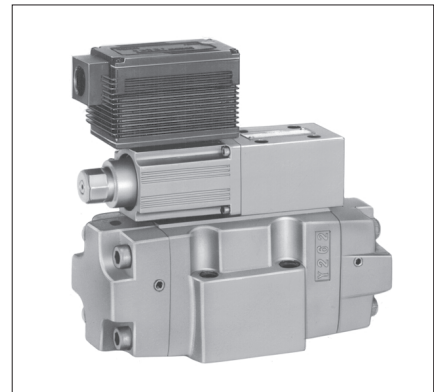

Graphic Symbols

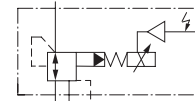

Open-Loop Type

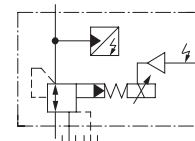

Open-Loop Type with Sensor

Sub-Plate

Valve Model No.	Sub-Plate Model No.	Thread Size Rc	Mass kg
EHRBG-06	ERBGM-06-20	3/4	3.0
EHRBG-10	ERBGM-10-10	1 1/4	6.5

● Sub-plates are available. Specify sub-plates model from the table above. When sub-plates are not used, the mounting surface should have a good machined finish. (▽)

Accessories

● **Mounting Bolts**

Model No.	Socket Head Cap Screw
EHRBG-06	M10 × 70 L.....4 Pcs.
EHRBG-10	M10 × 70 L.....6 Pcs.

Instructions

● **Pressure at the Primary Pressure Port**

The necessary pressure at the primary pressure port should be equal to the set pressure plus 1 MPa.

● **Drain Port**

The back pressure at the drain port should be less than 0.2 MPa. The pipe from the drain port should be connected to the reservoir directly and the end of the pipe must always be in the oil.

● **Load Capacity**

The use of the valves at the load capacity of about 20 L is recommended. Even at the lowest, a load capacity of more than 1.4 L is required.

● **EHRBG-06- * -50 : Open-Loop Type**

● **EHRBG-06- * -S-50 : Open-Loop Type with Sensor**

Approx. Mass
 Open-Loop Type12.3 kg
 Open-Loop Type with Sensor13 kg

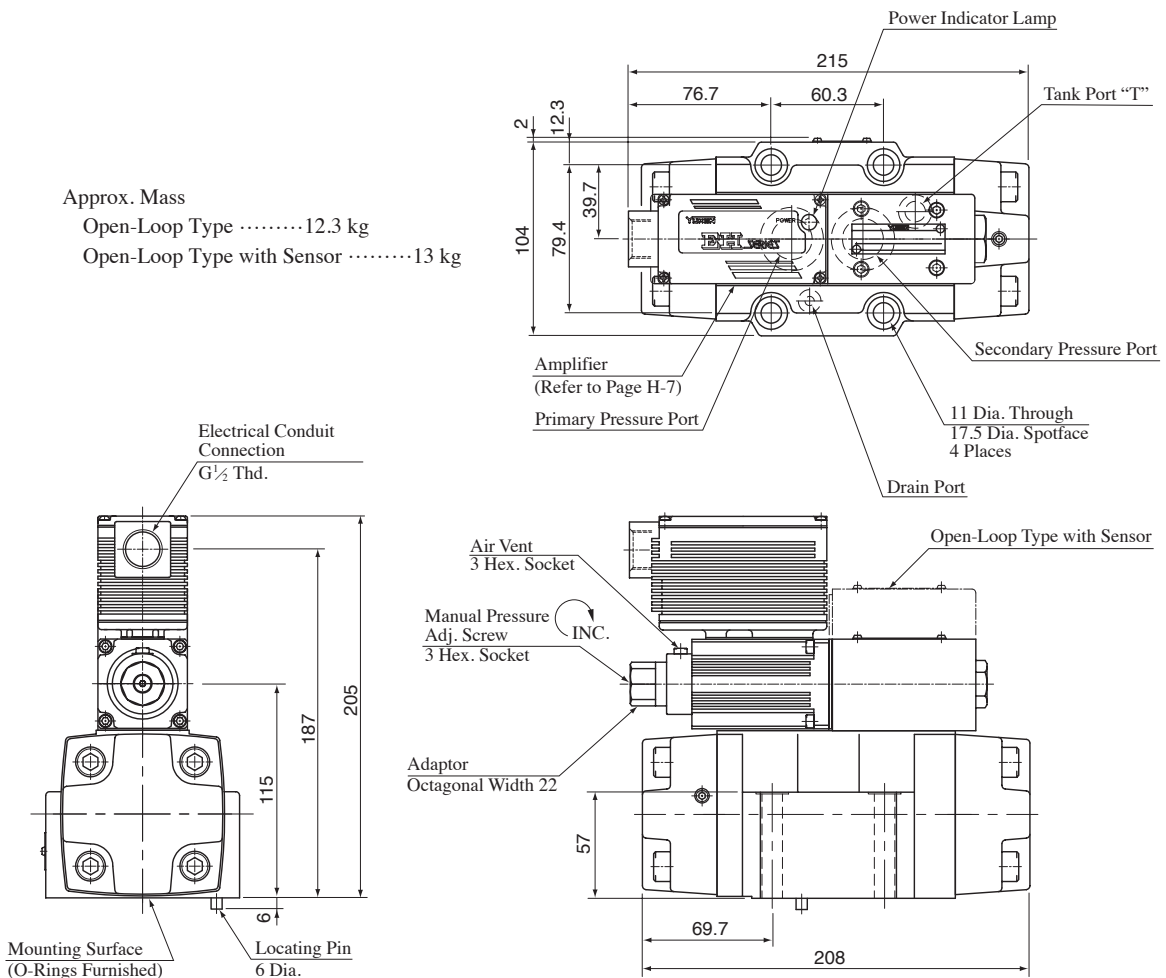

- **EHRBG-10- *-50 : Open-Loop Type**
- **EHRBG-10- *-S-50 : Open-Loop Type with Sensor**

Approx. Mass
 Open-Loop Type13.8 kg
 Open-Loop Type with Sensor14.5 kg

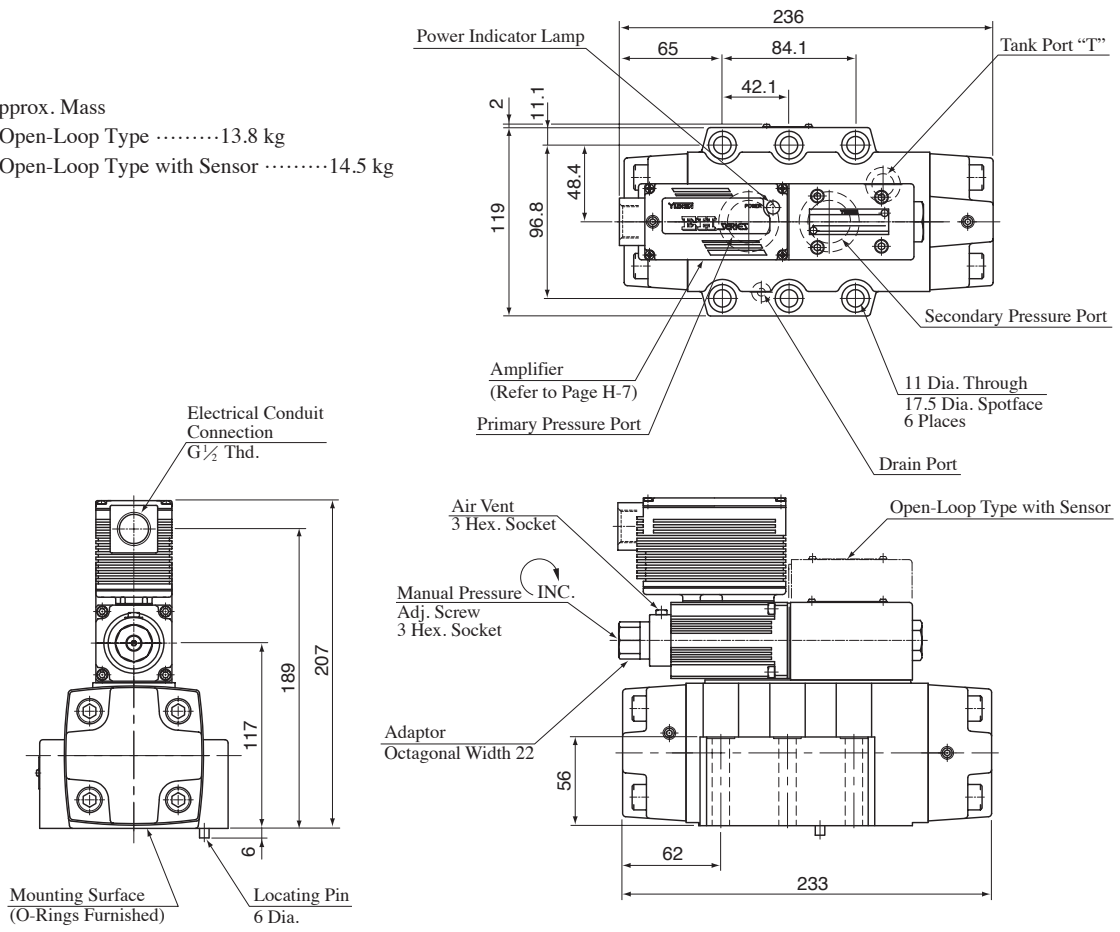

Sub-Plates

ERBGM-06

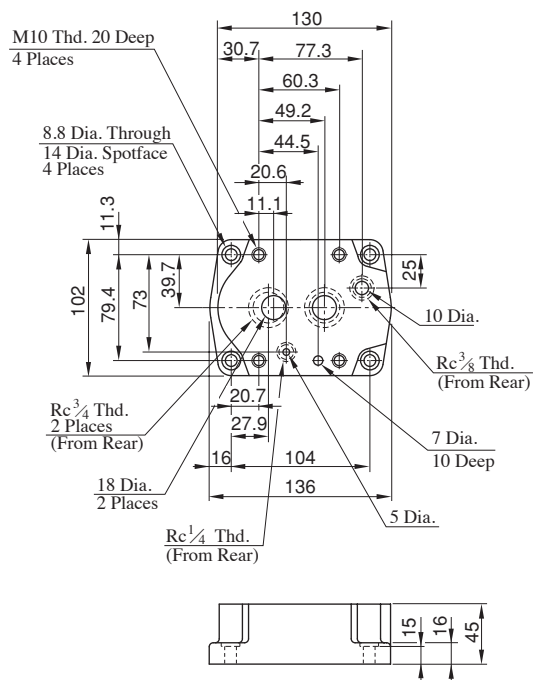

ERBGM-10

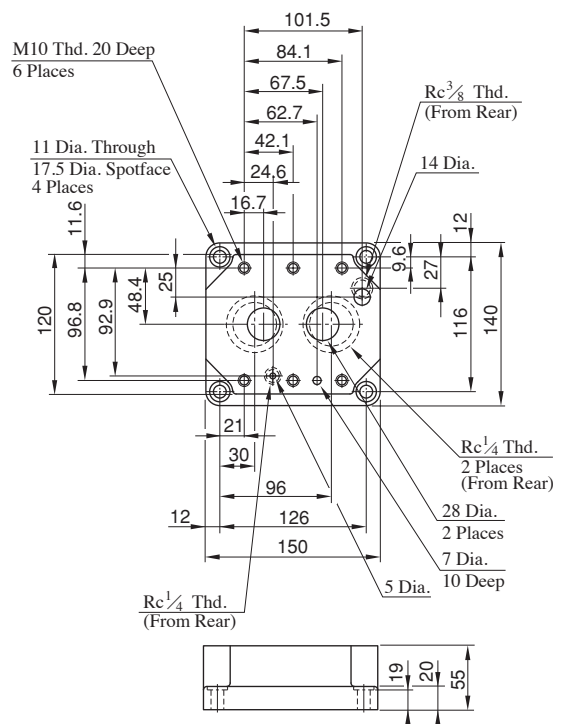

Input Signal Voltage vs. Secondary Pressure

Primary Pressure : 24.5 MPa
Viscosity : 30 mm²/s

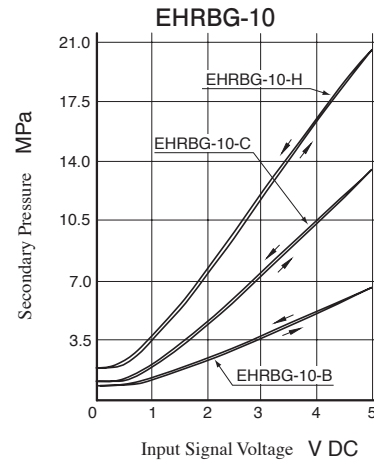
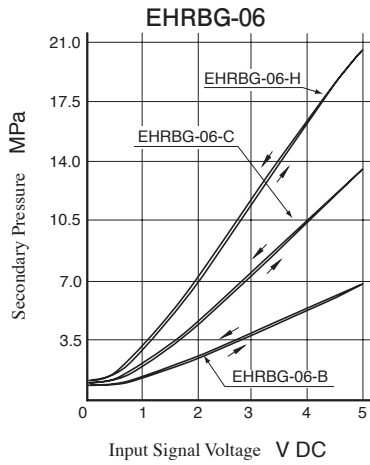

Flow vs. Secondary Pressure

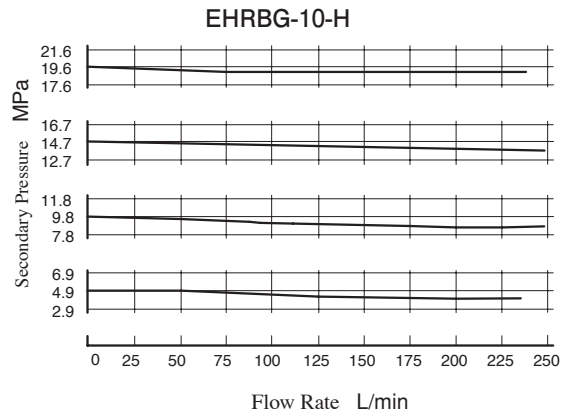
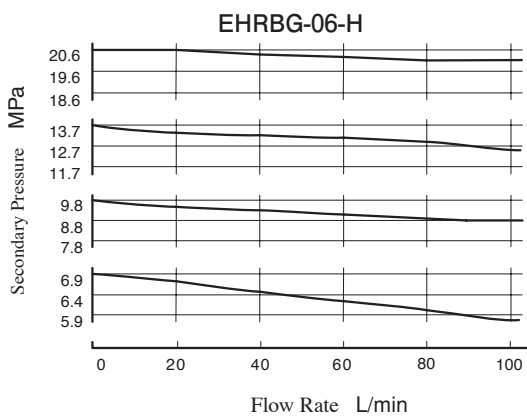
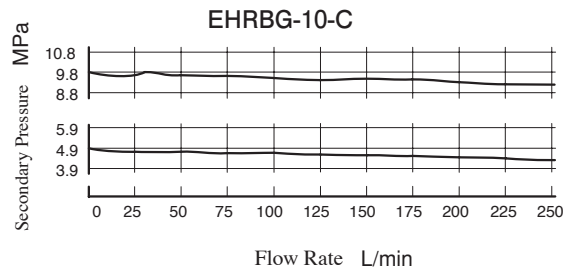
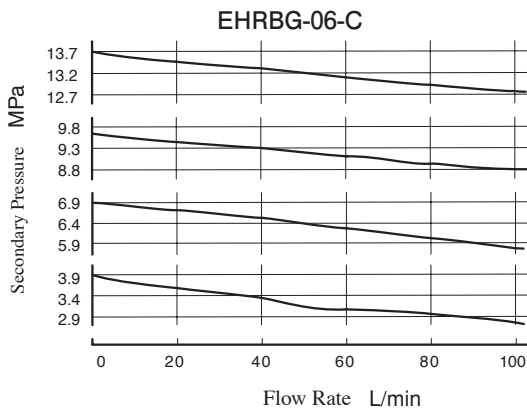
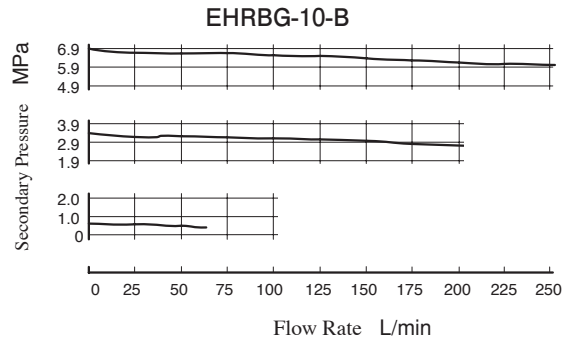
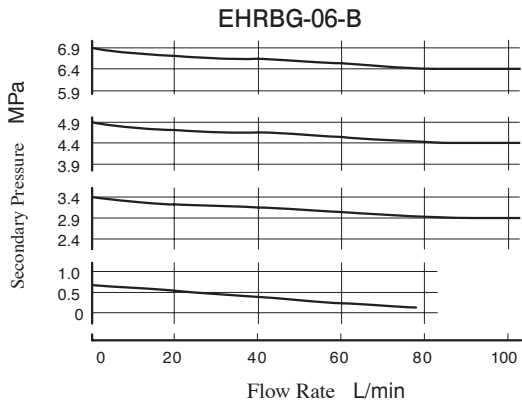

Viscosity vs. Secondary Pressure

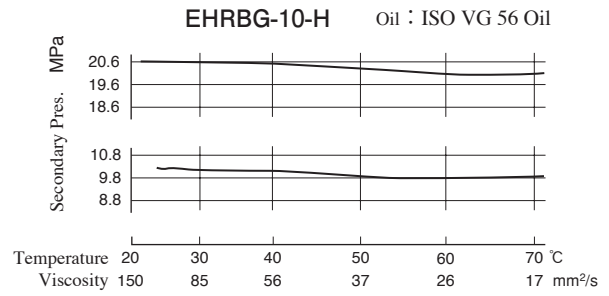
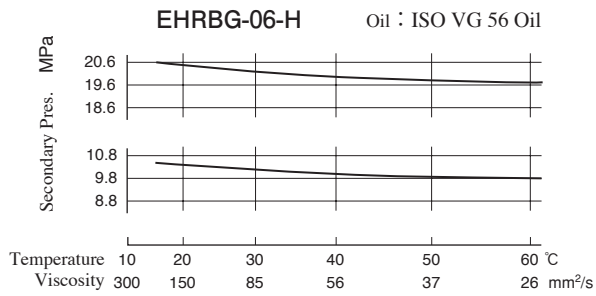
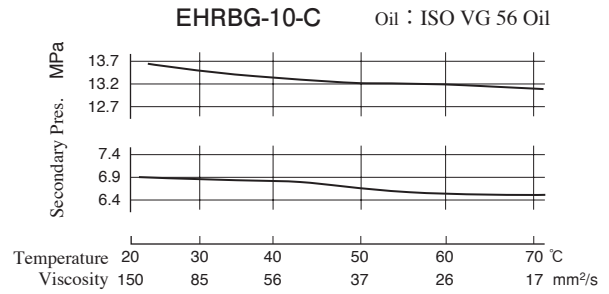
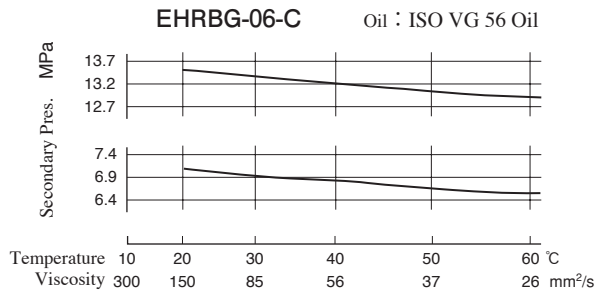
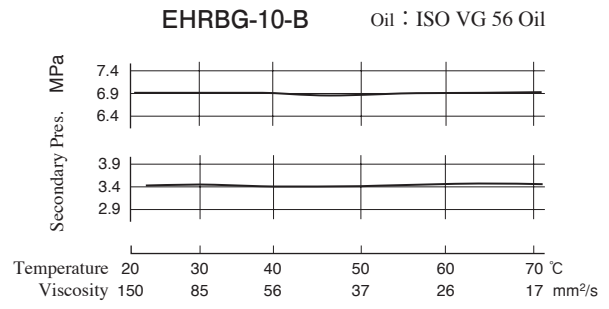
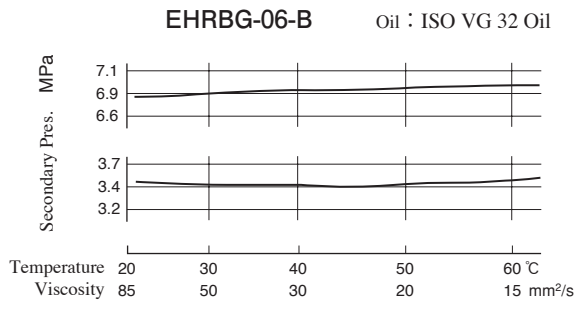

Step Response (Example)

The following step response measurements are taken when the trapped oil volume is 20 L. The step response varies by trapped oil volume.

Primary Pressure : 24.5 MPa
 Trapped Oil Volume : 20 L
 Viscosity : 30 mm²/s

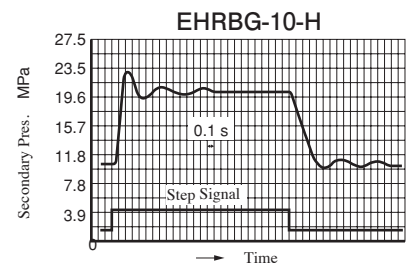
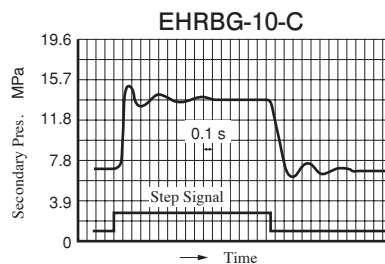
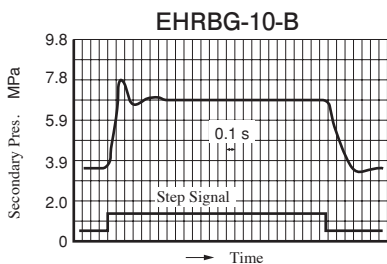
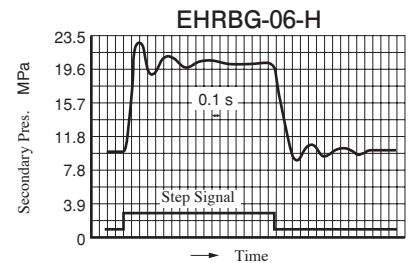
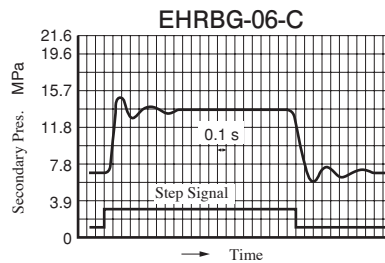
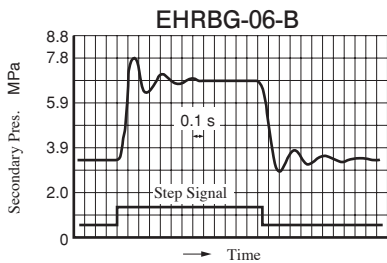

Frequency Response

Primary Pressure : 24.5 MPa
 Trapped Oil Volume : 20 L
 Viscosity : 30 mm²/s

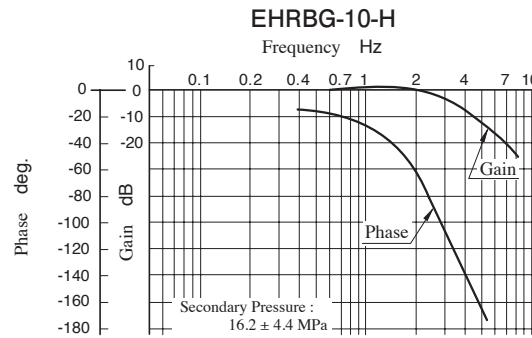
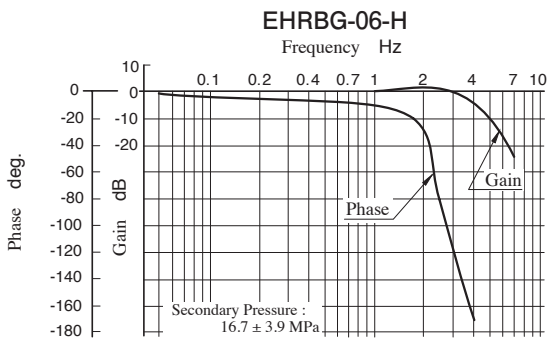
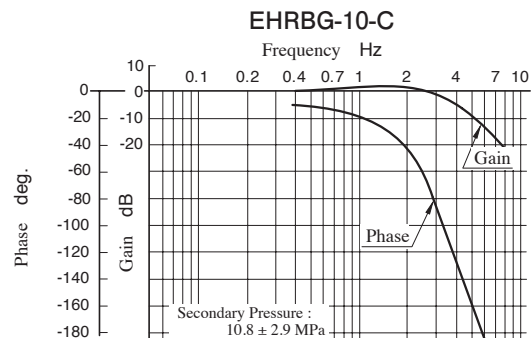
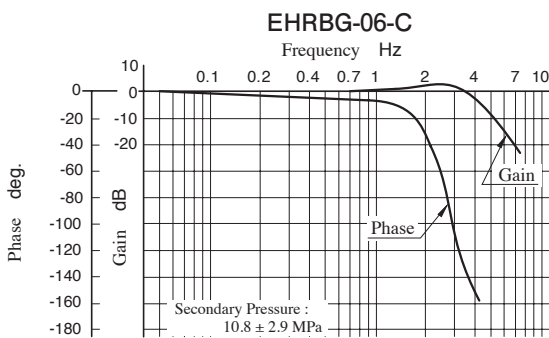
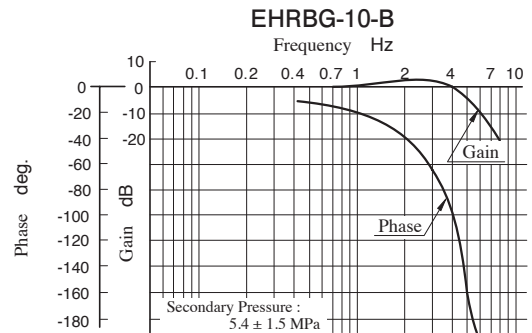
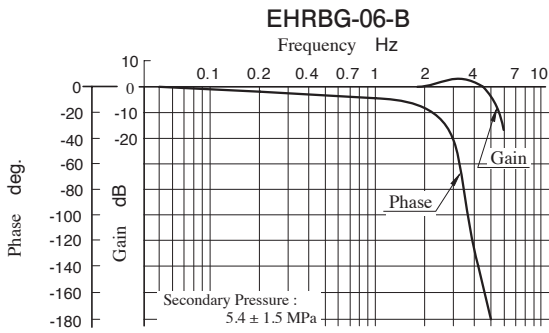

Proportional Electro-Hydraulic Flow Control (and Check) Valves

The system flow rate can be controlled remotely as desired by regulating input voltage. Further, since pressure and temperature compensation functions are provided, the preselected flow rate is not affected by pressure (load) or temperature (fluid viscosity).

Specifications

Model Numbers	EHF*G-03- 60 125	EHF*G-06-250
Descriptions		
Max. Operating Pres. MPa	20.6	24.5
Max. Metered Flow L/min	60 : 60 125 : 125	250
Min. Metered Flow L/min	1	2.5
Min. Differential Pressure* ¹ MPa	1.0	1.0
Free Flow (Only with Check Valve) L/min	130	280
Pilot Flow L/min	at Normal 0.5 at Transition 2.6	1 4
Min. Pilot Pressure MPa	1.0	1.5
Frequency Response	12 Hz (-90 degree)	
Hysteresis	3% or less	
Repeatability	1%* ² or less	
Coil Resistance	10 Ω	
Supply Electric Power	24 V DC (21 to 28 V DC Included Ripple)	
Power Input (Max.)	28 W	
Input Signal Voltage	Max. Metered Flow / 5V DC	
Input Impedance	10 k Ω	
Ambient Temperature	0 - 50°C (With Circulated Air)	
Mass	10 kg	25 kg

- ★ 1. Minimum differential pressure means fine pressure compensation at inlet and outlet port.
- ★ 2. The repeatability of the valve is obtained by having it tested independently on the conditions similar to its original testing.

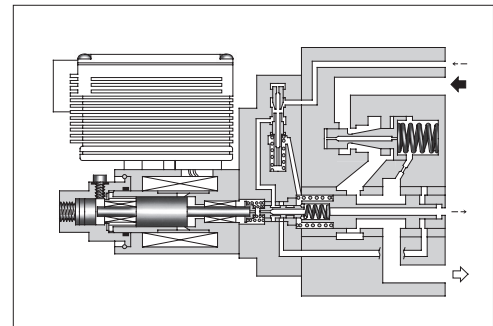
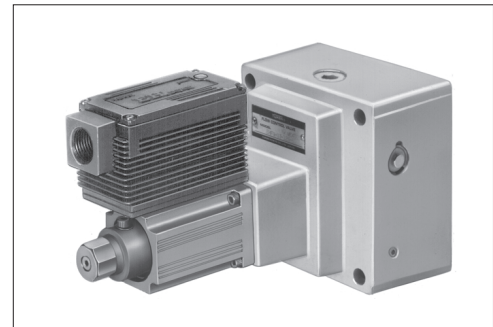

Graphic Symbols

● EHF

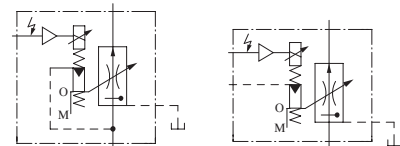

Internal Pilot

External Pilot

● EHFC

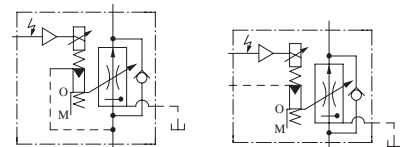

Internal Pilot

External Pilot

Model Number Designation

EHF	G	-03	-60	-E	-50
Series Number	Type of Mounting	Valve Size	Max. Metered Flow L/min	Pilot Connection	Design Number
EHF: Proportional Electro-Hydraulic Flow Control Valve	G: Sub-Plate Mounting	03	60 : 60 125 : 125	None: Internal Pilot	50
EHFC: Proportional Electro-Hydraulic Flow Control and Check Valve		06	250 : 250	E: External Pilot	50

- ★ Phosphate ester type fluids are also supported. When phosphate ester type fluids are used, prefix "F-" to the model number because the special seals (fluororubber) are required to be used.

Accessories

● Mounting Bolts

Model Numbers	Socket Head Cap Screw
EHFG EHFCG -03	M10 × 80 L.....4 Pcs.
EHFG EHFCG -06	M16 × 130 L.....4 Pcs.

Sub-Plate

Valve Model Numbers	Sub-Plate Model Numbers	Thread Size Rc	Mass kg
EHFG EHFCG -03	EFGM-03Y-30	3/4	5.7
	EFGM-03Z-30	1	5.6
EHFG EHFCG -06	EFGM-06X-30	1	12.5
	EFGM-06Y-30	1 1/4	16.0

● Sub-plates are available. Specify sub-plate model from the table left. When sub-plates are not used, the mounting surface should have a good machined finish. (√ $\frac{6}{7}$)

Instructions

● Drain Back Pressure

Check that the drain back pressure dose not exceed 0.2 MPa.

● Pilot Type Selection

This valve is constructed so as to operate at a predetermined pilot pressure.

For the 03, a pilot pressure of 1 MPa or higher is required. For the 06, the required pilot pressure is 1.5 MPa or higher.

To obtain such a required pilot pressure, select the pilot type according to the circuit examples on the right.

①/②

Use the external pilot type (type symbol: E) whether a meter-in or meter-out circuit is employed.

③

Use the internal pilot type (type symbol: None).

④

Use the external pilot type (type symbol: E).

[Example of Circuit]

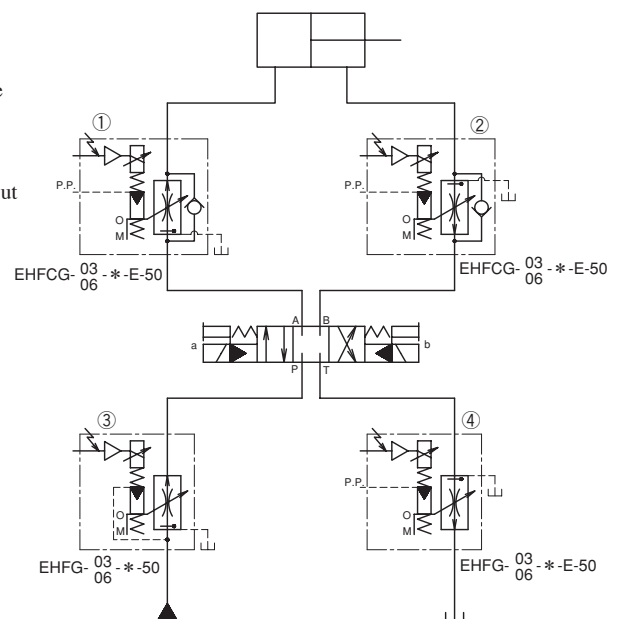

**EHFG
EHFCG⁻⁰³**

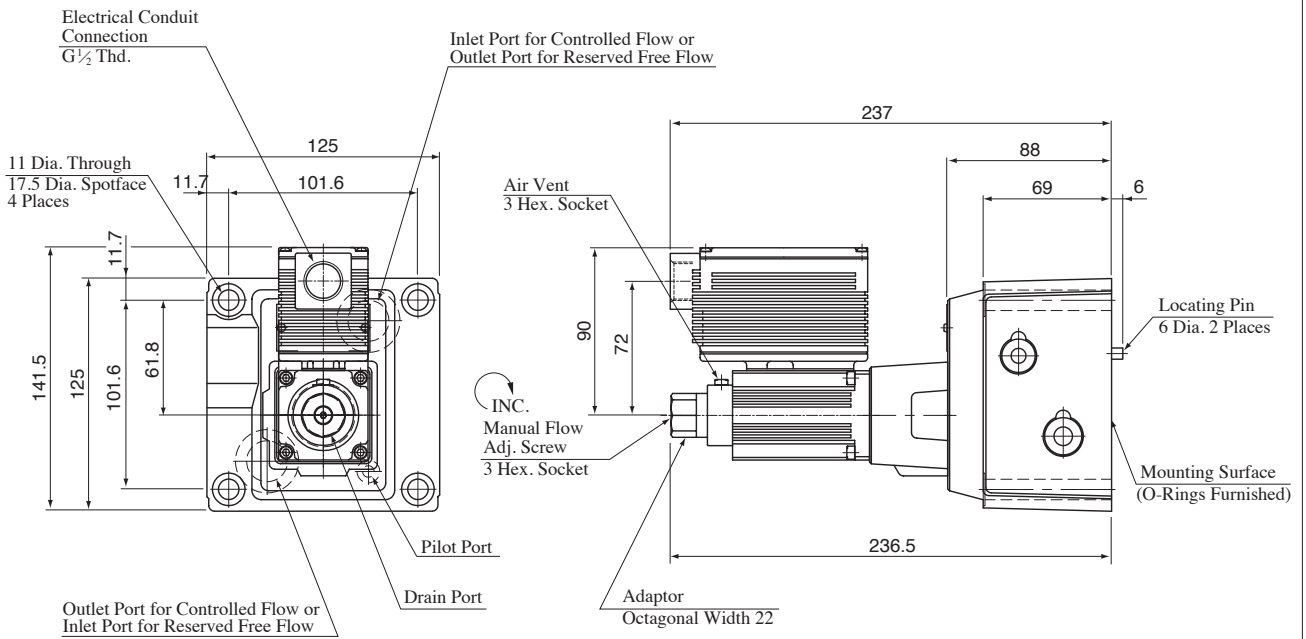

**EHFG
EHFCG⁻⁰⁶**

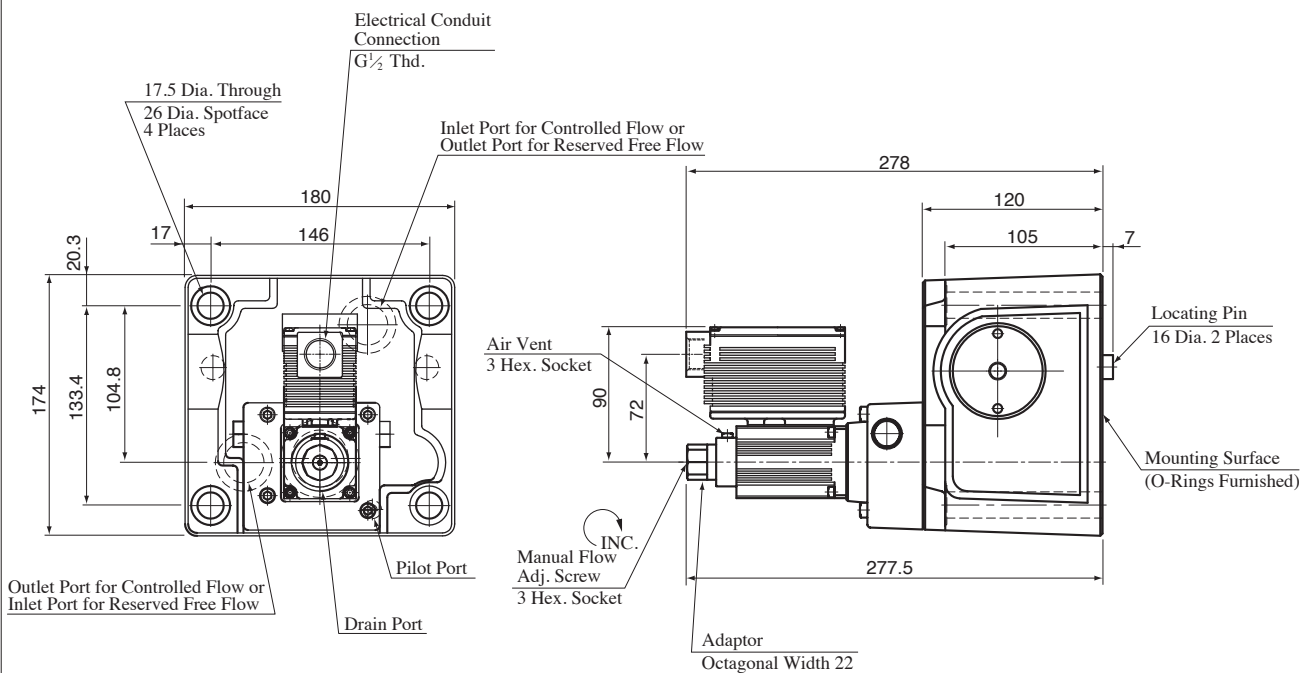

Detail of Amplifier

● Connecting Terminals

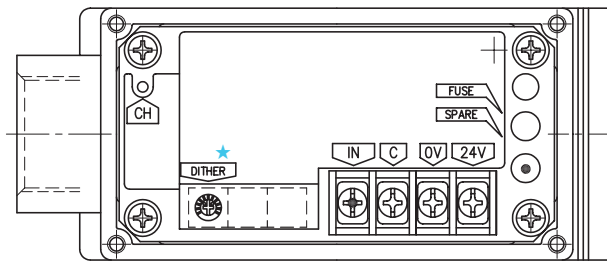

★DITHER

Use as it is since they are factory preset to the optimum position.
(Do not touch as it is in normal condition.)

Terminal	Name
IN	Input Signal (+)
C	Input Signal (COM)
0 V	Power Supply
24 V	
CH	Output Current Check (to C)

● Circuit Schematic

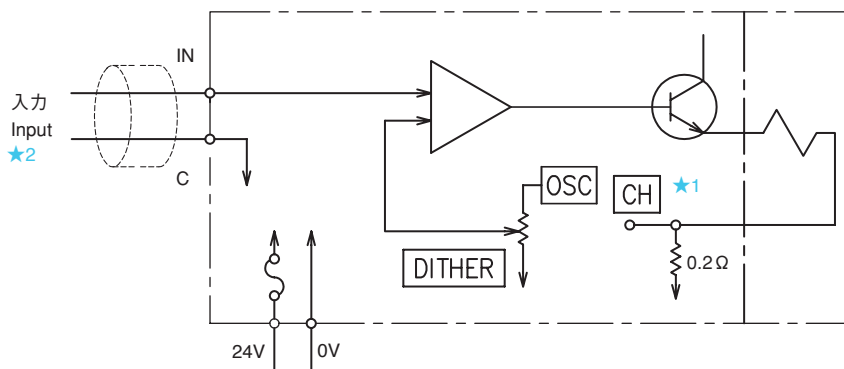

★1. For “CH” terminal, external instruments should have input impedance of more than 10 kΩ.

★2. Use shielded cable for “Input” connection. The ground of the shielded cable must be connected to input signal side.

Sub-Plates

EFGM-03Y, 03Z

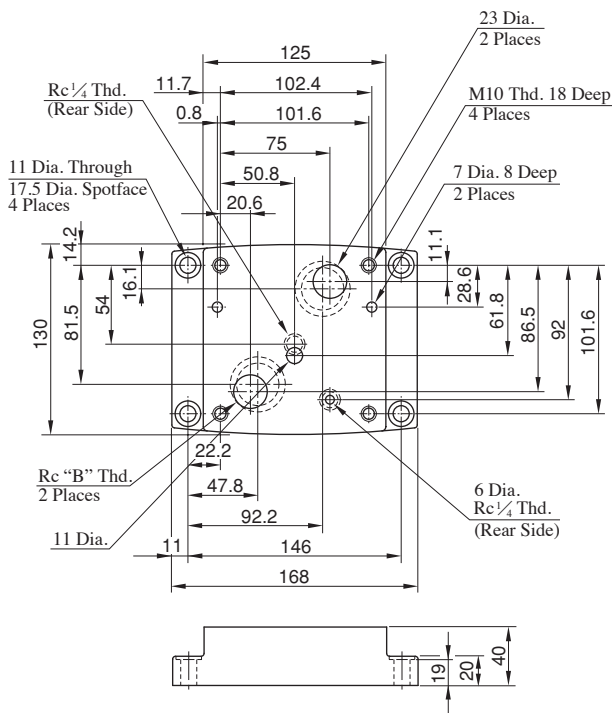

Sub-Plate Model Numbers	B
EFGM-03Y-30	3/4
EFGM-03Z-30	1

EFGM-06X, 06Y

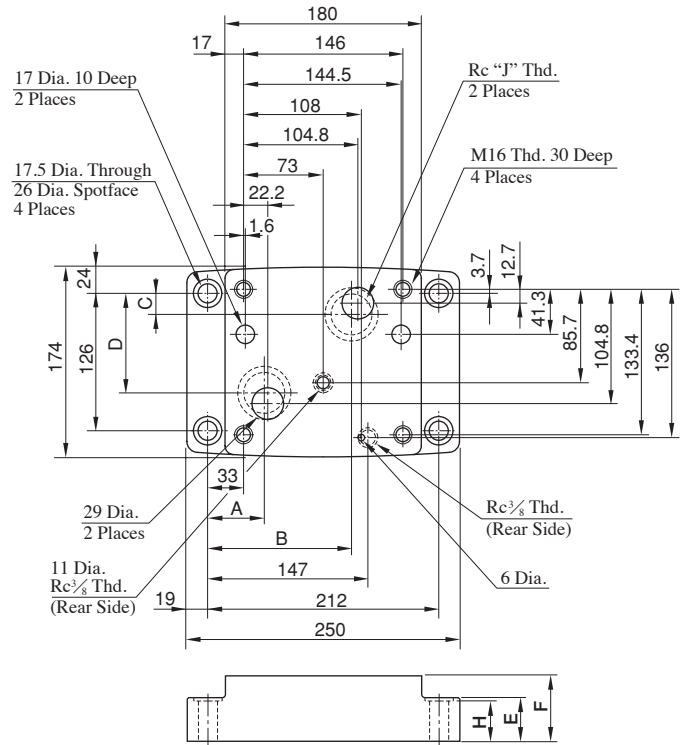

Sub-Plate Model Numbers	A	B	C	D	E	F	H	J
EFGM-06X-30	55.2	137.8	14.3	101.1	35	45	34	1
EFGM-06Y-30	52	132	19.3	91.3	40	60	39	1 1/4

Input Signal Voltage vs. Flow Rate

Viscosity : 30 mm²/s

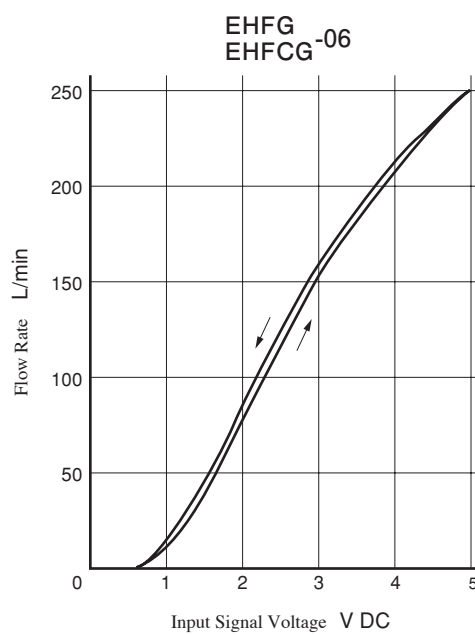
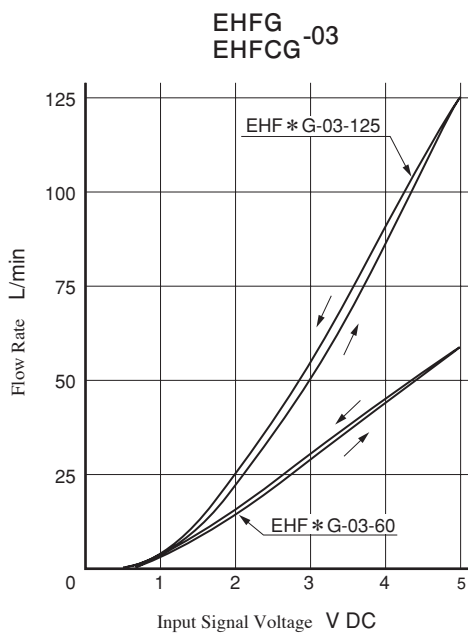

Differential Pressure vs. Flow Rate

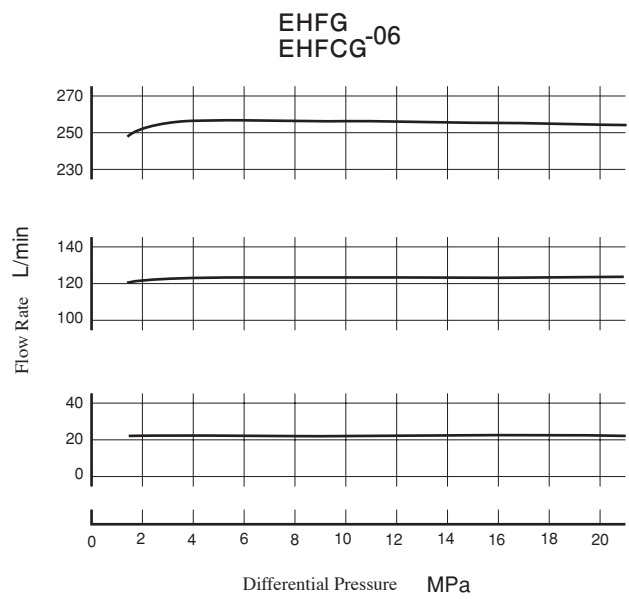
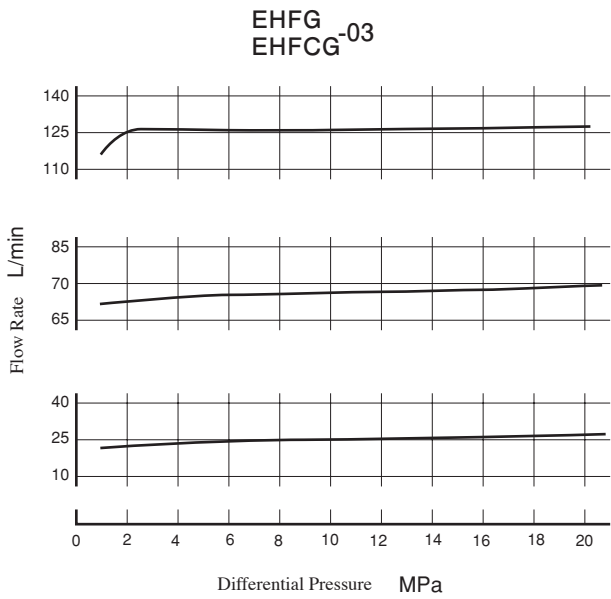

Viscosity vs. Flow Rate

Oil : ISO VG 46 Oil

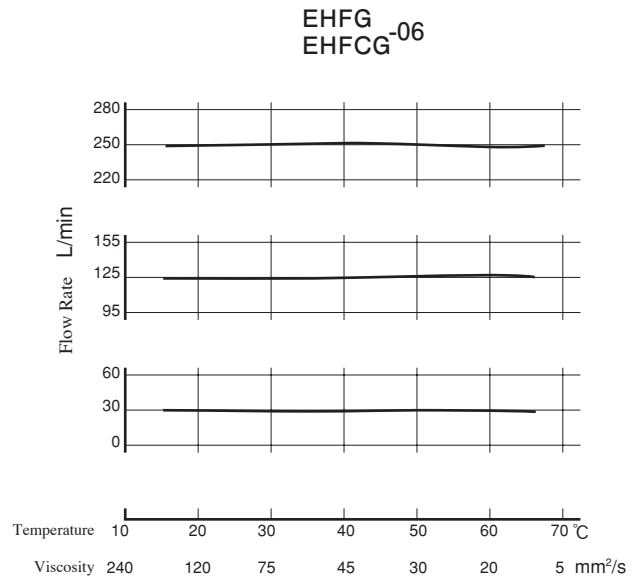
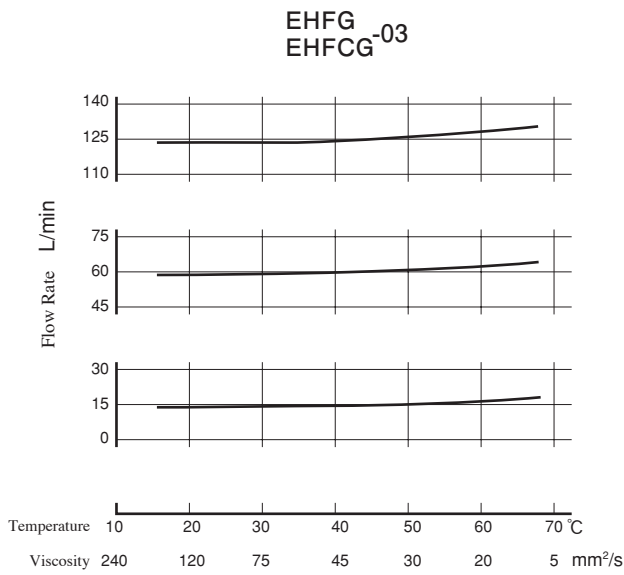

Step Response (Example)

The step responses right are those obtained when the valve itself is tested independently. The step responses may differ from them when the valve is used in combination with other control valves.

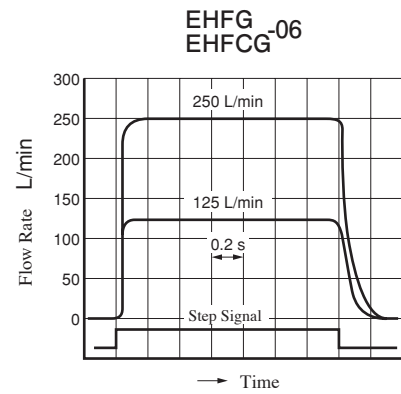
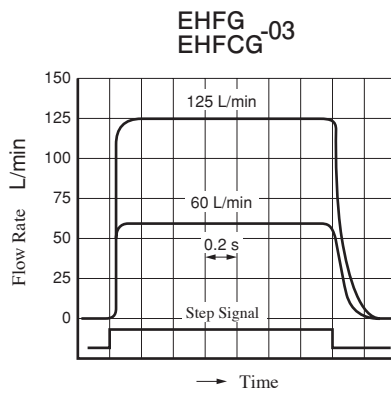

Frequency Response

Trapped Oil Volume : 1 L
 Viscosity : 30 mm²/s

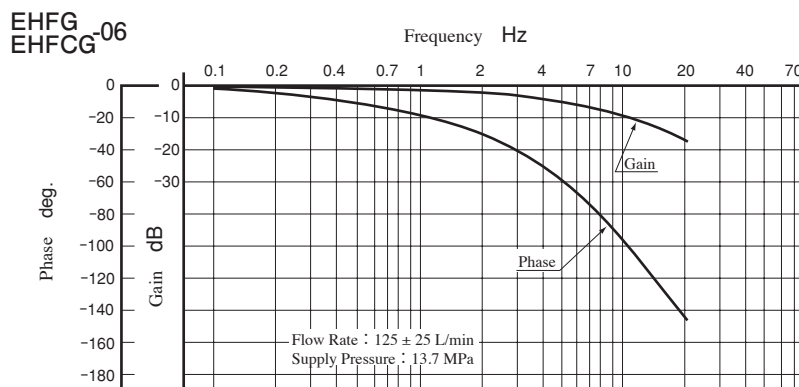
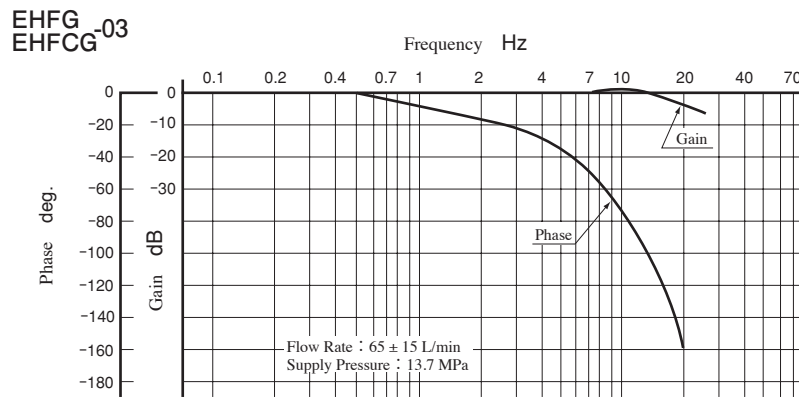

Proportional Electro-Hydraulic Flow Control and Relief Valves

These are proportional electro-hydraulic flow control valves having functions for controlling the direct electric current of meter-in type and for pressure control. They are energy-saving valves for supplying the minimum pressure and flow required to operate actuators.

Specifications

Model Numbers		EHFBG-03-*	EHFBG-06-250	EHFBG-10-500	
Descriptions					
Max. Operating Pressure	MPa	24.5	24.5	24.5	
Max. Flow	L/min	60 : 60 125 : 125	250	500	
Metered Flow Capacity	L/min	60 : 1-60 125 : 1-125	2.5-250	5-500	
Min. Pilot Pressure	MPa	1.5	1.5	1.5	
Pilot Flow	at Normal	1	1	1	
	at Transition	3	4	6	
Differential Pressure	MPa	0.6	0.7	0.9	
Flow Controls	Hysteresis	3% or less			
	Repeatability	1%* or less			
	Input Signal Voltage	Max. Flow / 5 V DC			
	Coil Resistance	10 Ω			
	Supply Electric Power	24 V DC (21 to 28 V DC Included Ripple)			
	Input Impedance	10 kΩ			
	Power Input (Max.)	28 W			
Pressure Controls	Pres. Adj. Range	Adj. Range:C	1.2-15.7	1.4-15.7	1.5-15.7
		Adj. Range:H	1.4-24.5	1.4-24.5	1.5-24.5
	Hysteresis	2% or less			
	Repeatability	1%* or less			
	Coil Resistance	10 Ω			
	Input Signal Voltage	Max. Adj. Pres. / 5 V DC			
	Supply Electric Power	24 V DC (21 to 28 V DC Included Ripple)			
Input Impedance	10 kΩ				
Power Input (Max.)	28 W				
Output Signal (Sensor Monitor)	C : 5 V DC / 15.7 MPa H : 5 V DC / 24.5 MPa				
Ambient Temperature	0 - 50°C (With Circulated Air)				
Mass	Refer to Pages H-38 to H-40				

- ★1. The repeatability of the valves is obtained by having it tested independently on the conditions similar to its original testing.
- ★2. The specifications for pressure controls is applied to models with pilot relief valve. (Ex. EHFBG-03-125-C-* -50)
- ★3. Pressure adjustment range of the valves without pilot relief valves (Ex. EHFBG-03-125-* -50) is from a minimum adjustable pressure to 25 MPa.

Model Number Designation

EHFB	G	-03	-60	-C	-E	-S	-50
Series Number	Type of Mounting	Valve Size	Max. Metered Flow L/min	Pilot Relief Valve Pres. Adj. Range	Pilot Connection of Flow Control	Pressure Controls	Design Number
EHFB : Proportional Electro-Hydraulic Flow Control and Relief Valve	G: Sub-Plate Mounting	03	60 125	None: Without Proportional Pilot Relief Valve	None: Internal Pilot E: External Pilot	None: Open-Loop S: Open-Loop with Sensor	50
		06	250				50
		10	500	C, H : See Specifications			50

★ Phosphate ester type fluids are also supported. When phosphate ester type fluids are used, prefix "F-" to the model number because the special seals (fluororubber) are required to be used.

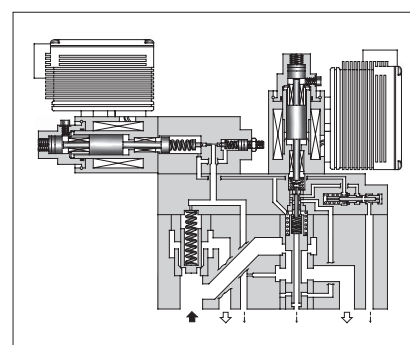
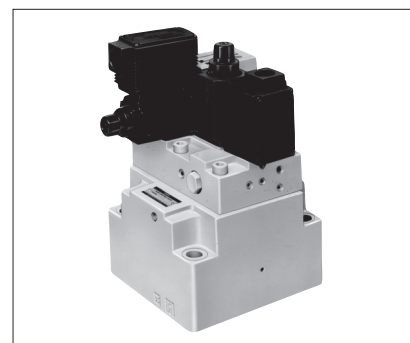

Graphic Symbols

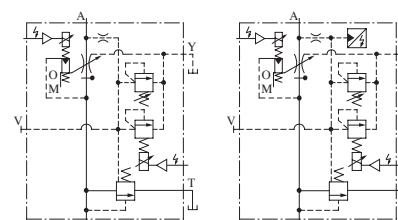

Models with Proportional Pilot Relief Valve

Models with Proportional Pilot Relief Valve and Sensor

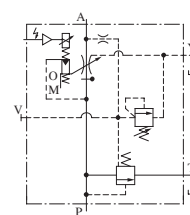

Models without Proportional Pilot Relief Valve



External Pilot Pres. Connection

Accessories

● **Mounting Bolts**

Model Numbers	Socket Head Cap Screw
EHFBG-03-60/125	M10 × 65 L 4 Pcs.
EHFBG-06-250	M16 × 100 L 4 Pcs.
EHFBG-10-500	M20 × 130 L 4 Pcs.

Sub-Plate

Valve Model Numbers	Sub-Plate Model Numbers	Thread Size Rc	Mass kg
EHFBG-03	EFBGM-03Y-20	3/4	6
	EFBGM-03Z-20	1	6
EHFBG-06	EFBGM-06X-20	1	12.5
	EFBGM-06Y-20	1 1/4	16
EHFBG-10	EFBGM-10Y-20	1 1/2, 2Pipe Flange Mtg.	37

- Sub-plates are available. Specify sub-plate model from the table left. When sub-plates are not used, the mounting surface should have a good machined finish. ($\frac{1.6}{\sqrt{R}}$)
- EFBGM-10Y is special type sub-plate to be used with pipe flange. When ordering EFBGM-10Y specify pipe flange in addition to EFBGM-10Y. Refer to Engineering Information Catalogue.

Instructions

● **Drain Back Pressure**

Check that the drain back pressure does not exceed 0.2 MPa.

● **When Relief Valve Passing Flow Rate is Low in Pressure Control State**

To avoid preselected pressure instability, use a passing flow rate of 15 L/min or higher. Further, check that the tank-side back pressure does not exceed 0.5 MPa.

● **Safety Valve Pressure Setting**

The safety valve is preset to a pressure that is 2 MPa higher than the maximum adjustment pressure. Therefore, adjust this pressure setting as needed to suit the pressure used.

To lower the pressure setting, turn the safety valve pressure adjustment screw anti-clockwise. After adjustment, be sure to tighten the lock nut.

EHFBG-03- 60 - C (-E)- * -50
125 H

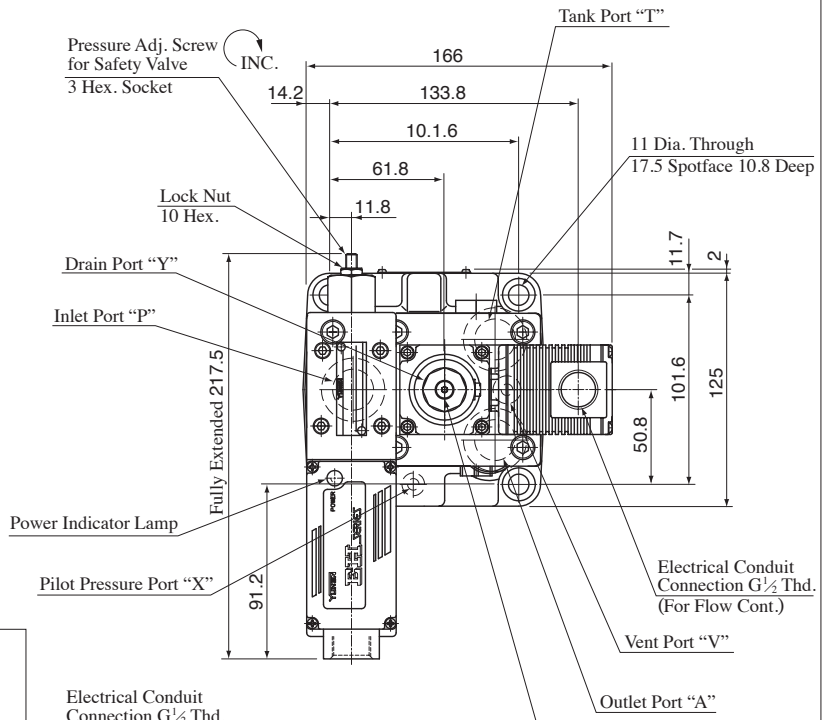

EHFBG-03- 60 (-E)-50
125

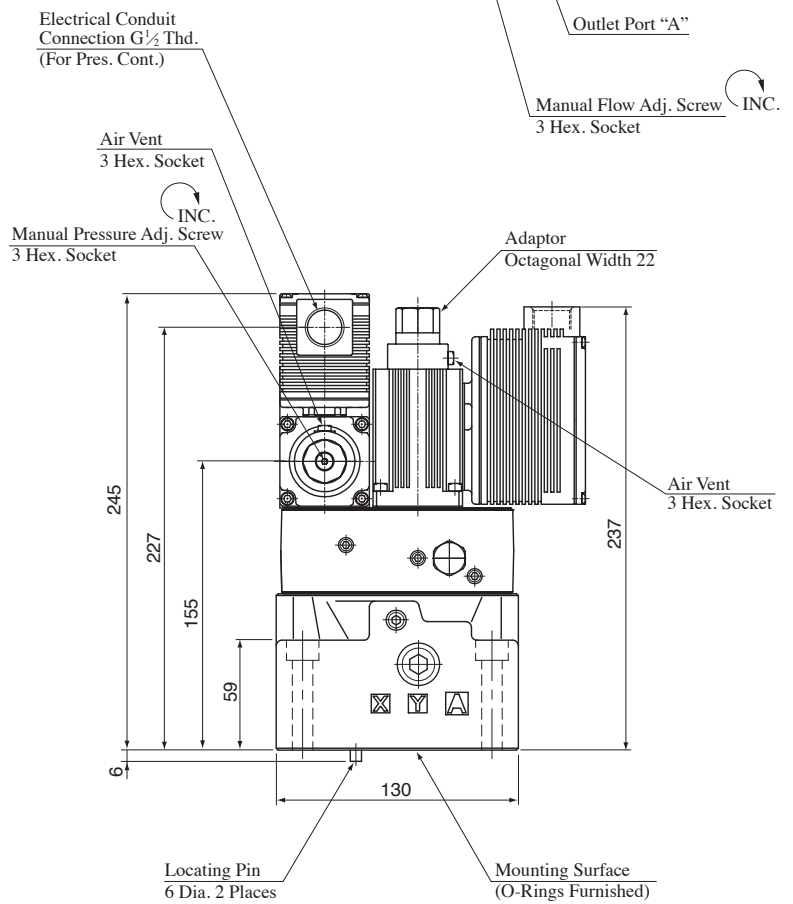
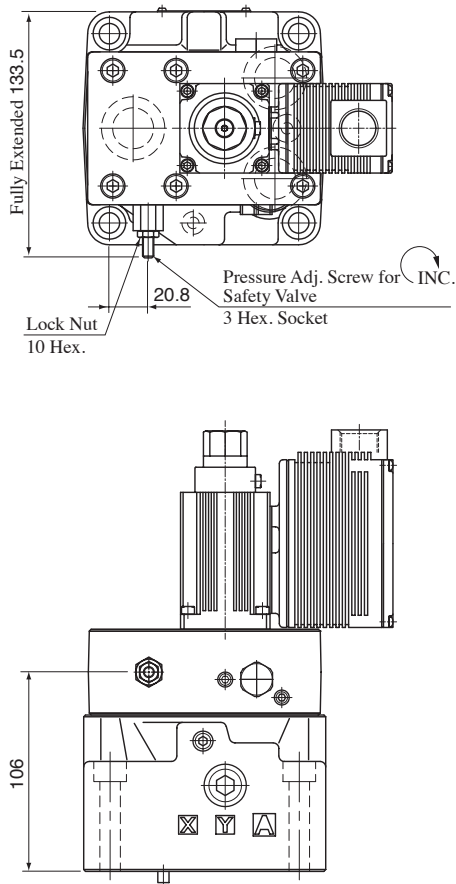

Mass 17 kg
(Models with Sensor 17.7 kg)

For other dimensions, refer to right drawing.
Mass 14.8 kg

EHFBG-06-250-C_H(-E)-* -50

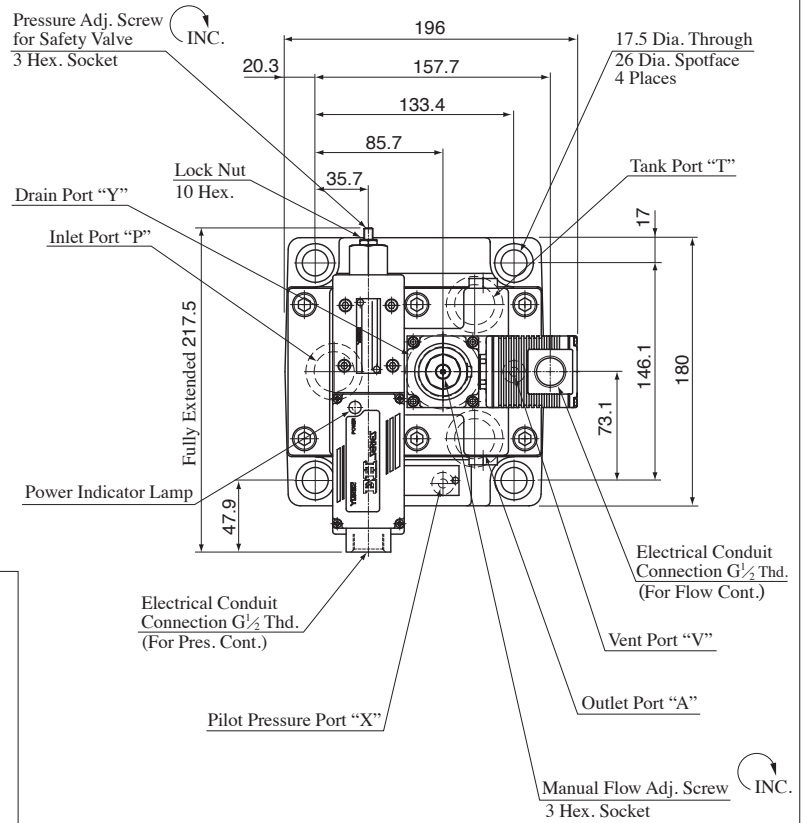

EHFBG-06-250(-E)-50

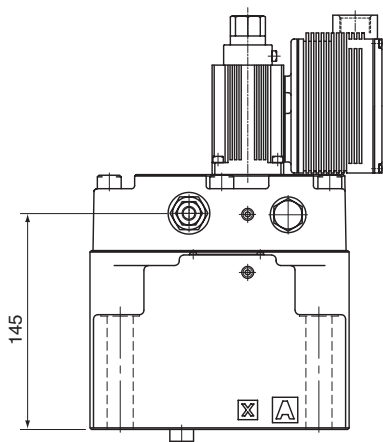
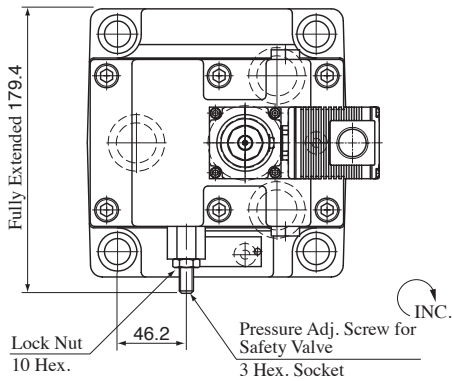

For other dimensions, refer to right drawing.
Mass 21.8 kg

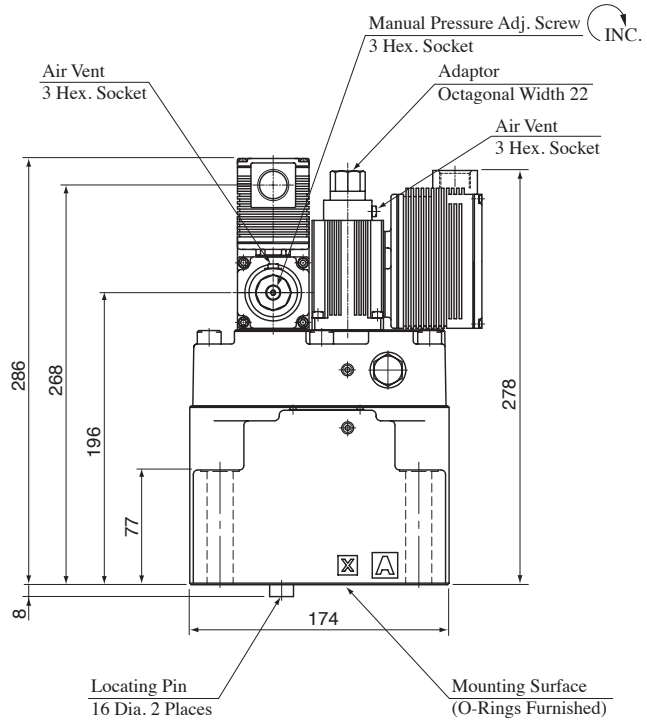

Mass 24 kg
(Models with Sensor 24.7 kg)

EHFBG-10-500-^C_H(-E)-* -50

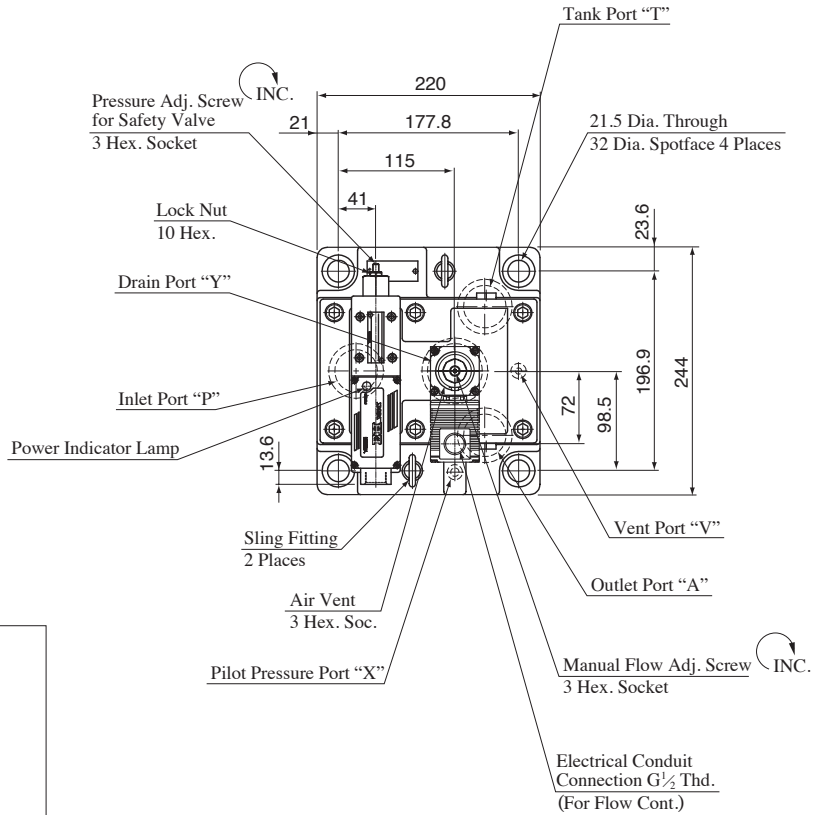

EHFBG-10-500(-E)-50

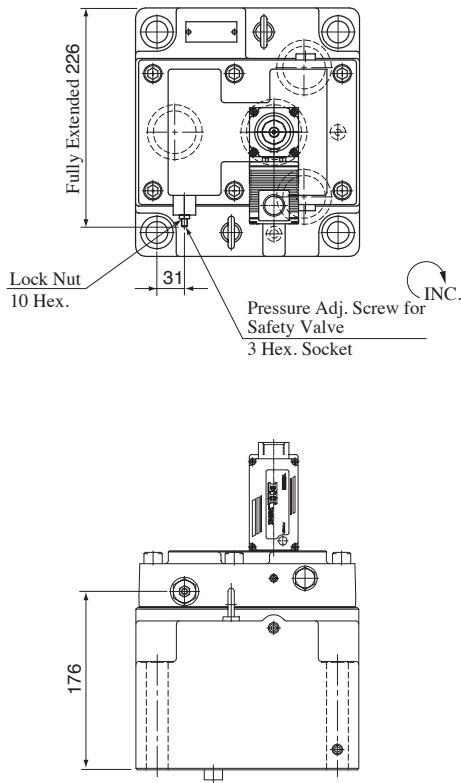

For other dimensions, refer to right drawing.
Mass 61.8 kg

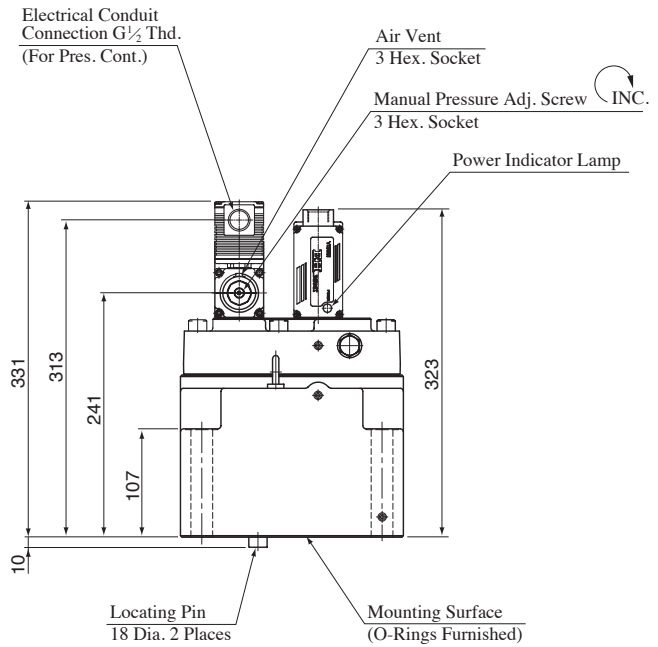

Mass 64 kg
(Models with Sensor 64.7 kg)

Detail of Amplifier

● Connecting Terminal

- Flow Control
- Pressure Controls...Open-Loop Type

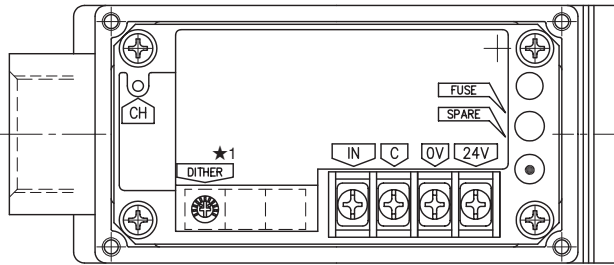

Terminal	Name
IN	Input Signal (+)
C	Input Signal (COM)
0 V	Power Supply
24 V	
CH	Output Current Check (to C)

- ★1. DITHER
Use as they are since they are factory-preset to the optimum position. (Do not touch them in normal condition.)
- ★2. GAIN
GAIN adjusting volume is not available.

● Pressure Controls...Open-Loop Type with Sensor

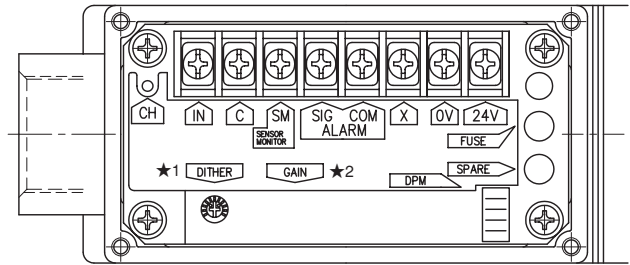

Terminal	Name	
IN	Input Signal (+)	
C	Input Signal (COM)	
SM	Sensor Monitor (to C)	
ALARM	SIG	} (Open)
	COM	
X	(Open)	
0 V	Power Supply	
24 V		
CH	Output Current Check (to C)	

● Circuit Schematic

● Flow Controls

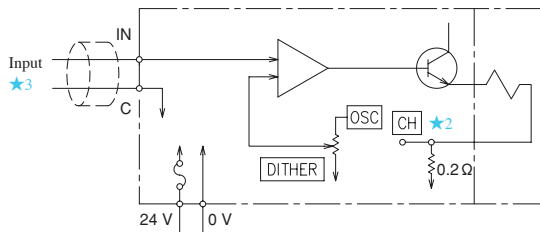

● Pressure Controls

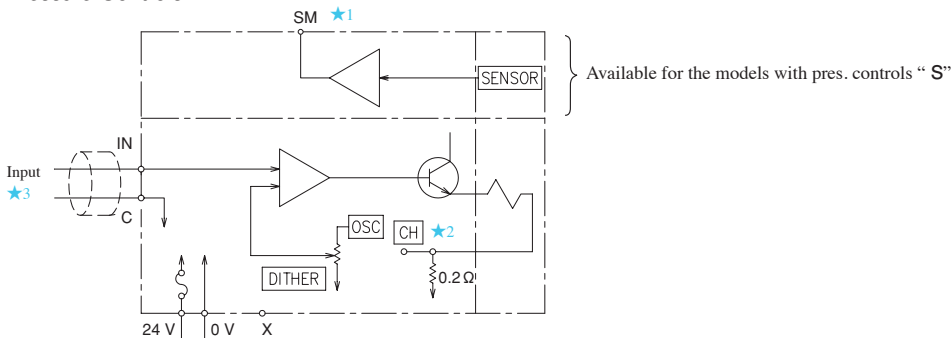

- ★1. For "SM" terminal, external instruments should have input impedance of more than 10 kΩ.
- ★2. For "CH" terminal, external instruments should have input impedance of more than 10 kΩ.
- ★3. Use shielded cable for "Input" connection. The ground of the shielded cable must be connected to input signal side.

Sub-Plate

EFBGM-03Y -20
03Z

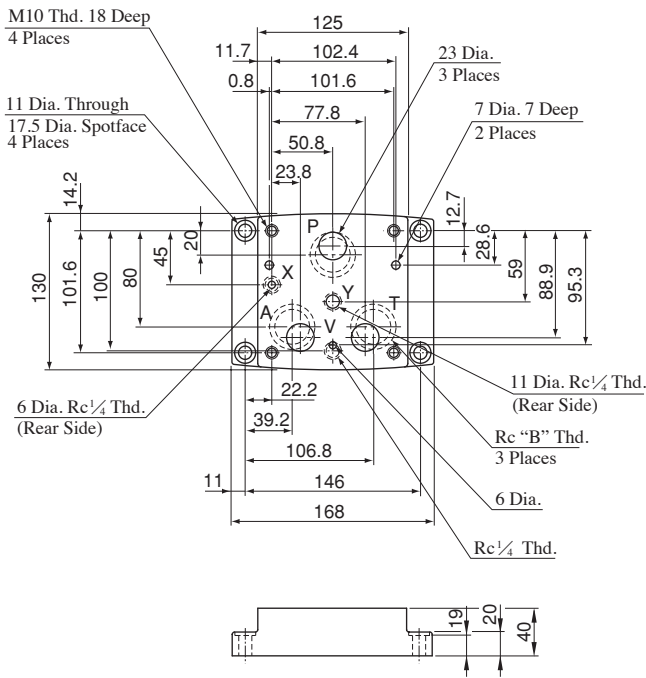

Sub-Plate Model Numbers	B
EFBGM-03Y-20	3/4
EFBGM-03Z-20	1

EFBGM-06X -20
06Y

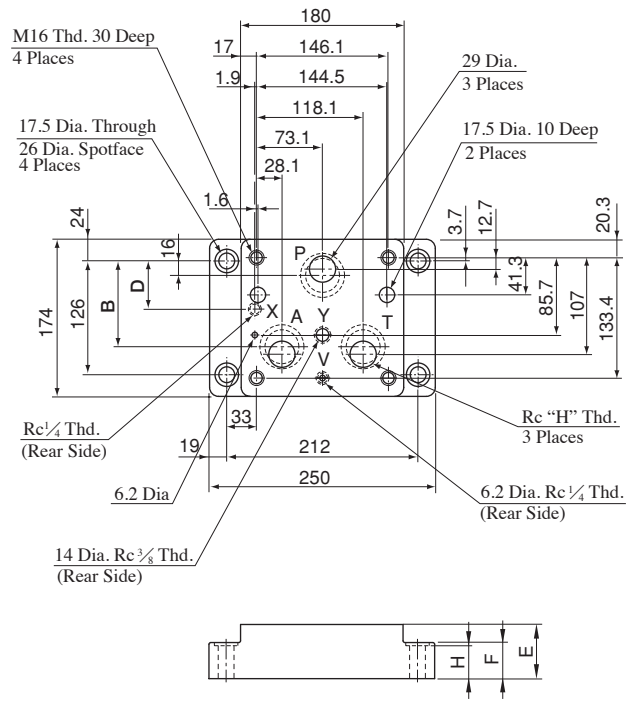

Sub-Plate Model Numbers	B	D	E	F	H
EFBGM-06X-20	107	67	45	35	1
EFBGM-06Y-20	95	57	60	40	1 1/4

EFBGM-10Y-20

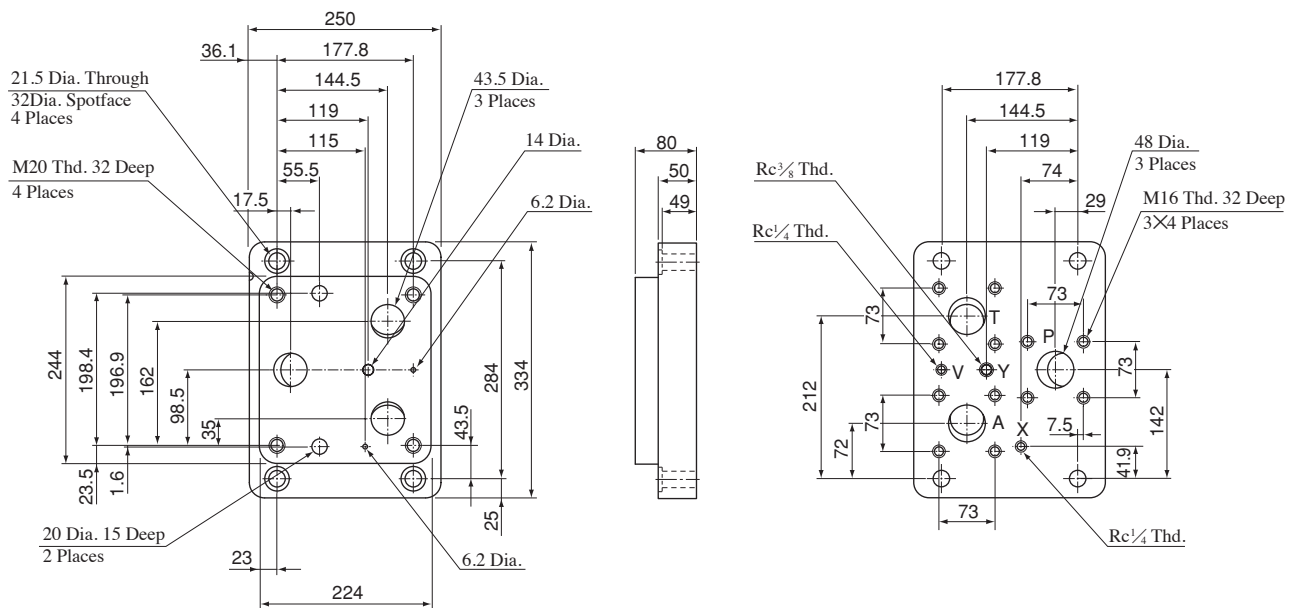

Input Signal Voltage vs. Flow

Viscosity : 30 mm²/s

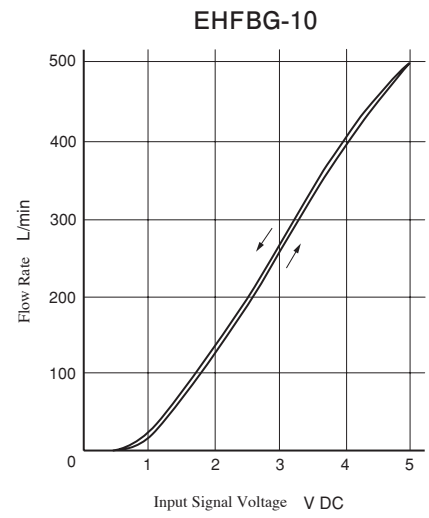
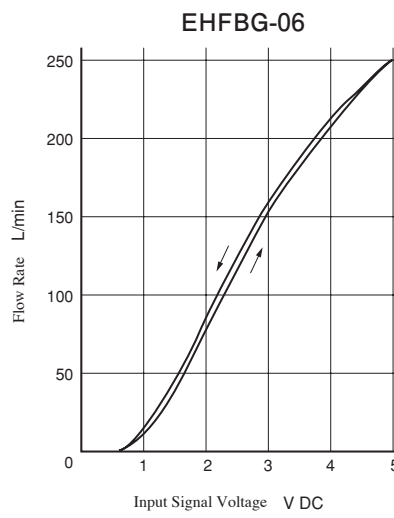
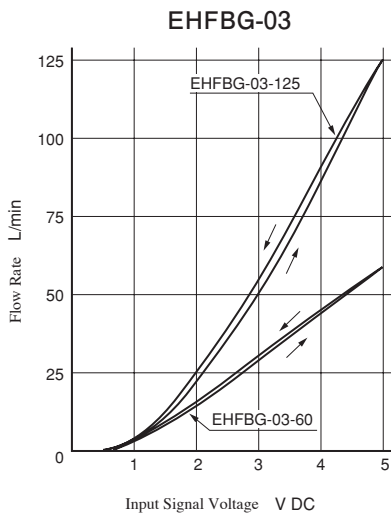

Input Signal Voltage vs. Pressure

Viscosity : 30 mm²/s

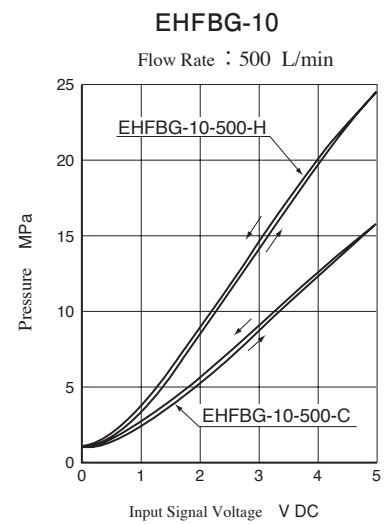
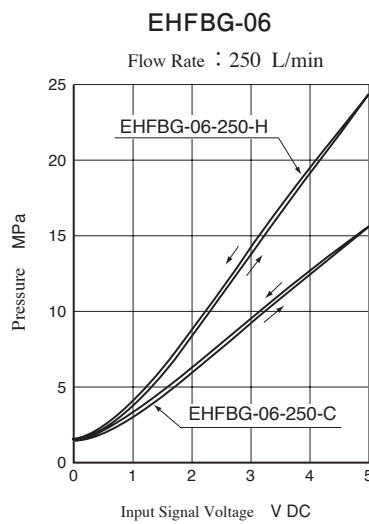
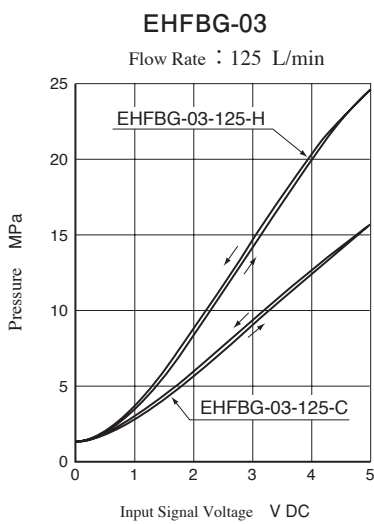

Step Response (Flow Controls)

Viscosity : 30 mm²/s

The step responses below are those obtained when the valve itself is tested independently.
The step responses may differ from them when the valve is used in combination with other control valves.

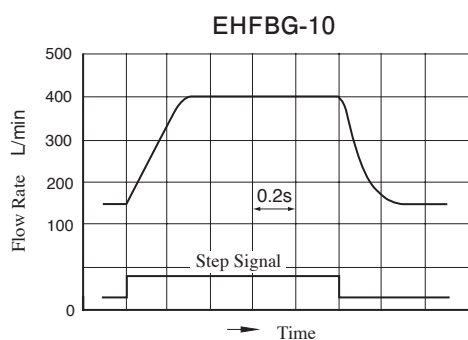
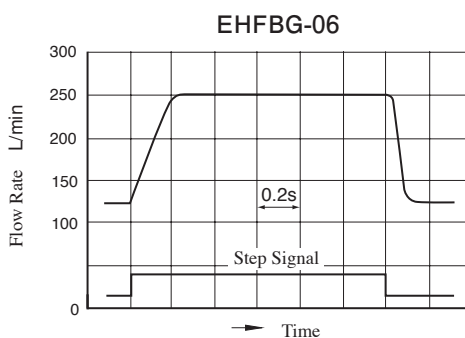
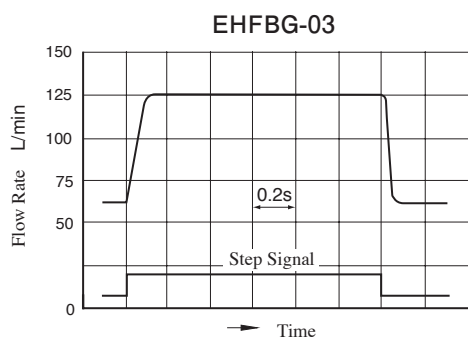

Step Response (Pressure Controls)

Viscosity : 30 mm²/s

The step responses below are those obtained when the valve itself is tested independently.
The step responses may differ from them when the valve is used in combination with other control valves.

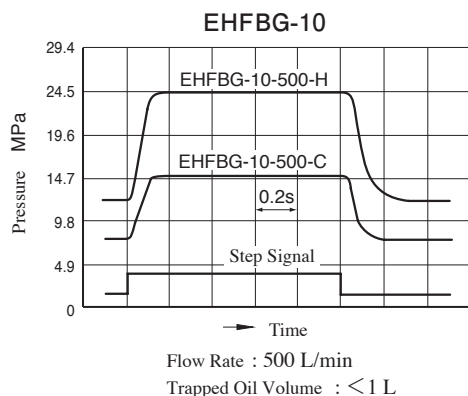
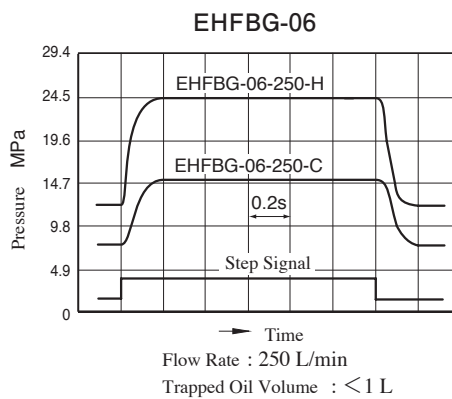
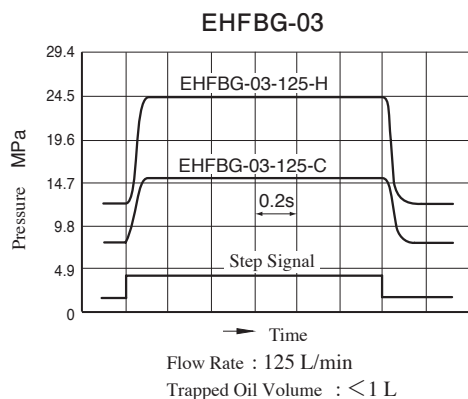

High Flow Series Proportional Electro-Hydraulic Flow Control and Relief Valves

This flow control and relief valve is a energy-saving valve that supplies the minimum pressure and flow necessary for actuator drive.

For the High Flow Series, double maximum flow rate [03 size: 125 → 250 L/min, 06 size: 250 → 500 L/min] enables a smaller valve size than conventional products; compact-sized devices can be provided.

Specifications

Model Numbers		EHFBG-03-250	EHFBG-06-500	
Descriptions				
Max. Operating Pressure	MPa	24.5	24.5	
Max. Flow	L/min	250	500	
Metered Flow Capacity	L/min	2.5-250	5-500	
Min. Pilot Pressure	MPa	1.5	1.5	
Pilot Flow	at Normal	1	1	
	at Transition	4	6	
Differential Pressure	MPa	0.8	0.9	
Flow Controls	Hysteresis	3% or less		
	Repeatability	1%* or less		
	Input Signal Voltage	Max. Flow / 5 V DC		
	Coil Resistance	10 Ω		
	Supply Electric Power	24 V DC (21 to 28 V DC Included Ripple)		
	Input Impedance	10 kΩ		
Pressure Controls	Power Input (Max.)	28 W		
	Pres. Adj. Range	Adj. Range:C	1.6-15.7	1.5-15.7
		MPa	Adj. Range:H	1.8-24.5
	Hysteresis	3% or less		
	Repeatability	1%* or less		
	Coil Resistance	10 Ω		
	Input Signal Voltage	Max. Adj. Pres. / 5 V DC		
	Supply Electric Power	24 V DC (21 to 28 V DC Included Ripple)		
Input Impedance	10 kΩ			
Power Input (Max.)	28 W			
Output Signal (Sensor Monitor)	C : 5 V DC / 15.7 MPa H : 5 V DC / 24.5 MPa			
Ambient Temperature	0 - 50°C (With Circulated Air)			
Mass	Refer to Pages H-47 to H-48			

- ★1. The repeatability of the valves is obtained by having it tested independently on the conditions similar to its original testing.
- ★2. The specifications for pressure controls is applied to models with pilot relief valve. (Ex. EHFBG-03-125-C- *-50)
- ★3. Pressure adjustment range of the valves without pilot relief valves (Ex. EHFBG-03-250- *-50) is from a minimum adjustable pressure to 24.5 MPa.

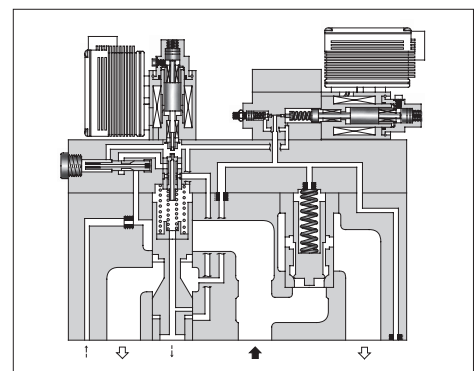

Graphic Symbols

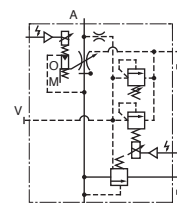

Models with Proportional Pilot Relief Valve

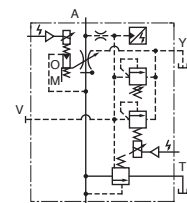

Models with Proportional Pilot Relief Valve and Sensor

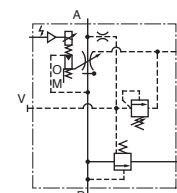

Models without Proportional Pilot Relief Valve



External Pilot Pres. Connection

Model Number Designation

EHFB	G	-03	-250	-C	-E	-S	-50
Series Number	Type of Mounting	Valve Size	Max. Metered Flow L/min	Pilot Relief Valve Pres. Adj. Range	Pilot Connection of Flow Control	Pressure Controls	Design Number
EHFB: Proportional Electro-Hydraulic Flow Control and Relief Valve	G: Sub-Plate Mounting	03	250	None: Without Proportional Pilot Relief Valve C, H: See Specifications	None: Internal Pilot E: External Pilot	None: Open-Loop S: Open-Loop with Sensor	50
		06	500				50

★ Phosphate ester type fluids are also supported. When phosphate ester type fluids are used, prefix “F-” to the model number because the special seals (fluororubber) are required to be used.

Accessories

● Mounting Bolts

Model Numbers	Socket Head Cap Screw
EHFBG-03-250	M12 × 120 L 4 Pcs.
EHFBG-06-500	M16 × 120 L 4 Pcs.

Instructions

● Drain Back Pressure

Check that the drain back pressure does not exceed 0.2 MPa.

● When Relief Valve Passing Flow Rate is Low in Pressure Control State

To avoid preselected pressure instability, use a passing flow rate of 15 L/min or higher.

Further, check that the tank-side back pressure does not exceed 0.5 MPa.

● Safety Valve Pressure Setting

The safety valve is preset to a pressure that is 2 MPa higher than the maximum adjustment pressure.

Therefore, adjust this pressure setting as needed to suit the pressure used.

To lower the pressure setting, turn the safety valve pressure adjustment screw anti-clockwise. After adjustment, be sure to tighten the lock nut.

EHFBG-03-250-C_H(-E)-* -50

EHFBG-03-250(-E)-* -50

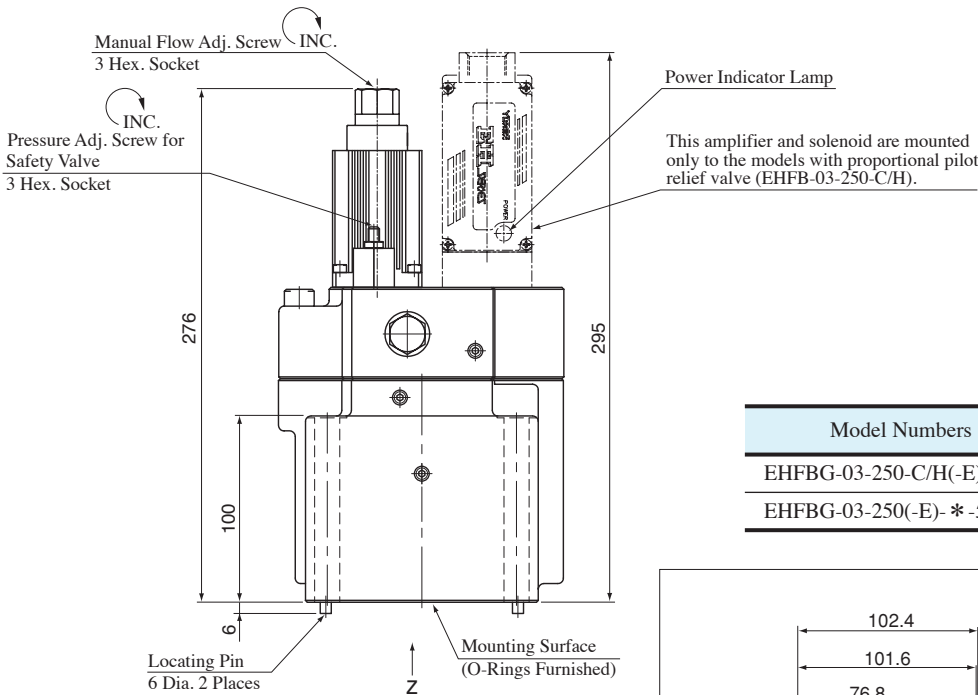
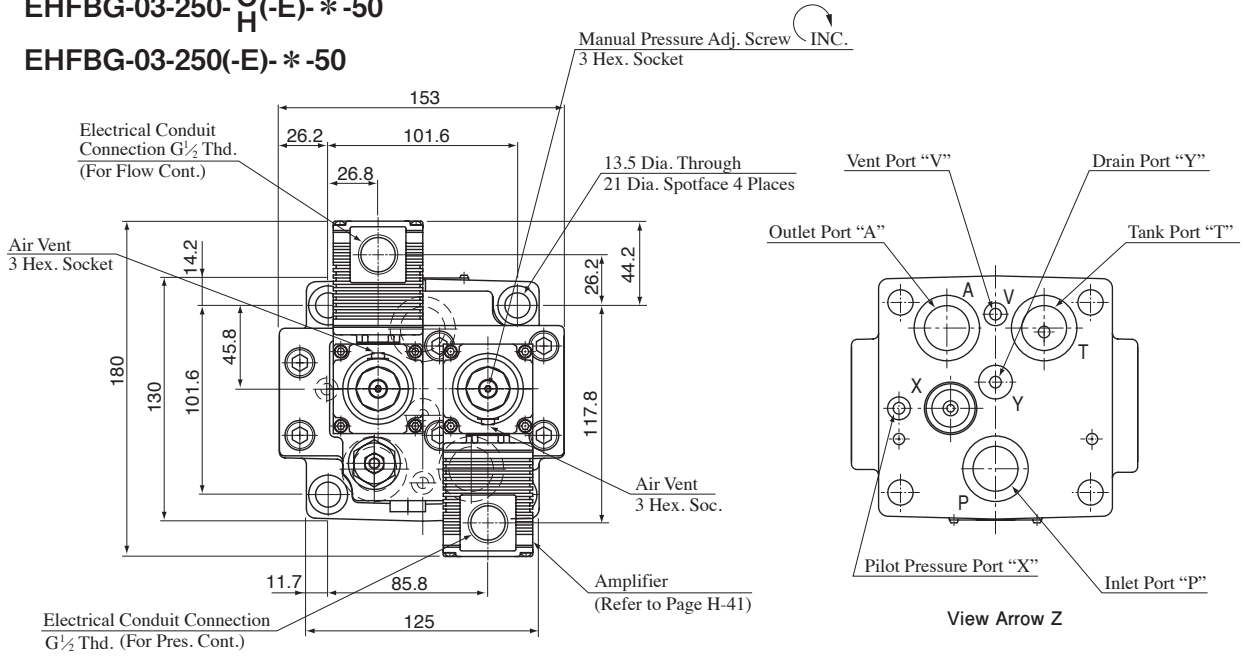

Model Numbers	Mass
EHFBG-03-250-C/H(-E)-* -50	19 kg
EHFBG-03-250(-E)-* -50	17.4 kg

Dimensions of Valve Mounting Surface
Prepare the mounting surface as shown on the right. It should be fine finished.

Mounting Interchangeability with Conventional Models
The high flow models are not interchangeable in mounting with the conventional models.

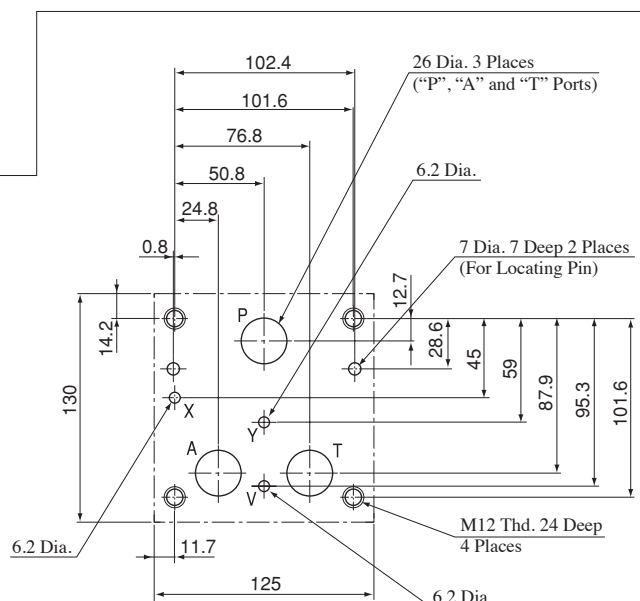

EHFBG-06-500-^C_H(-E)-* -50

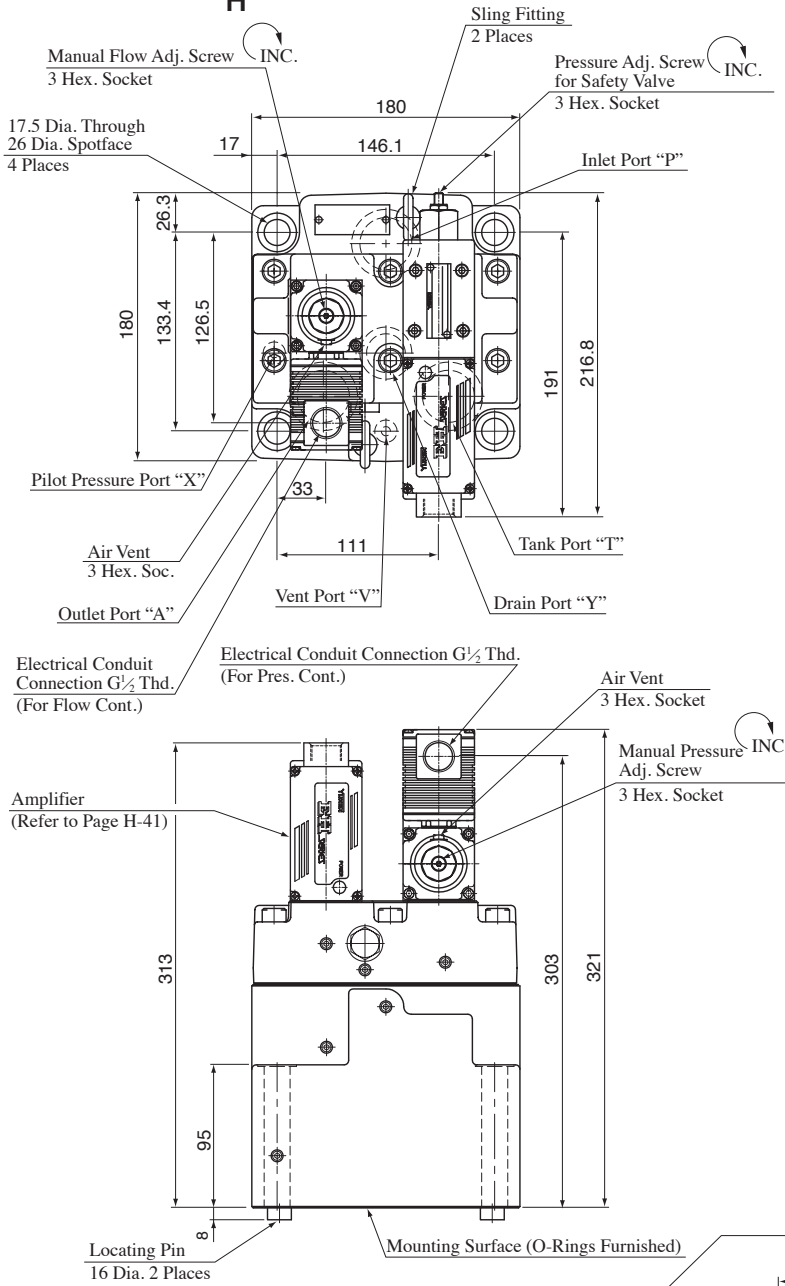

EHFBG-06-500(-E)-* -50

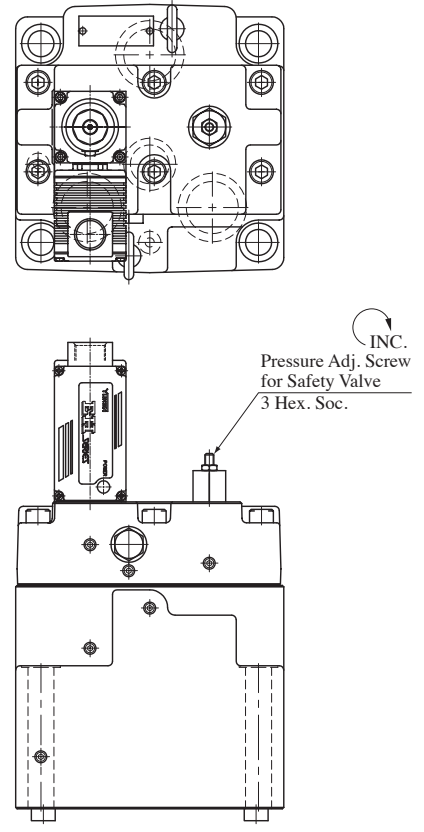

Mass 33.8 kg

For other dimensions, refer to left drawing.

Mass 36 kg

Dimensions of Valve Mounting Surface

Prepare the mounting surface as shown on the right. It should be fine finished.

Mounting Interchangeability with Conventional Models

A valve in the high-flow series can be mounted on the mounting surface for a conventional valve.

(Conventional valve : EHFBG-06-250 cannot be mounted on a mounting surface for the high-flow series.)

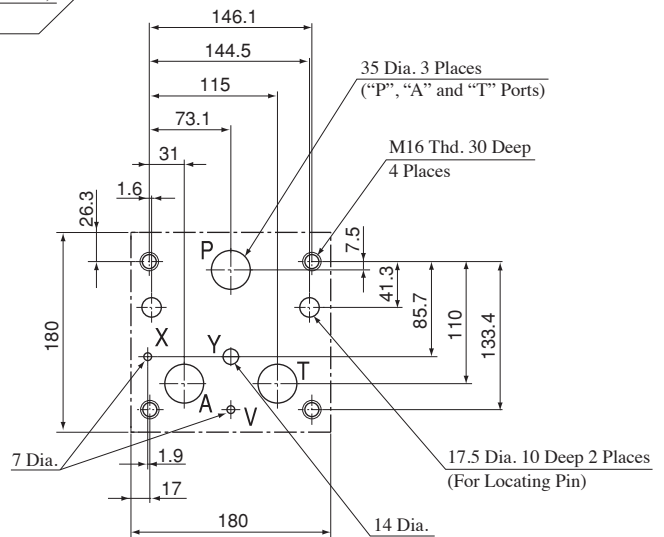

Input Signal Voltage vs. Flow

Viscosity : 30 mm²/s

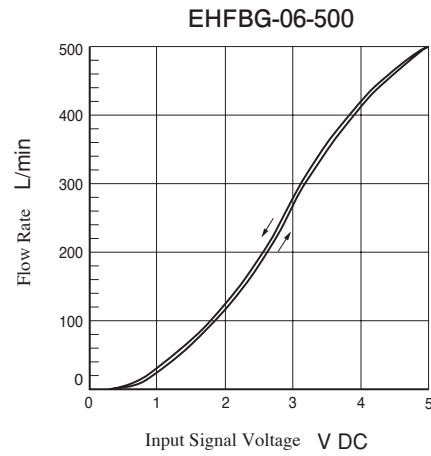
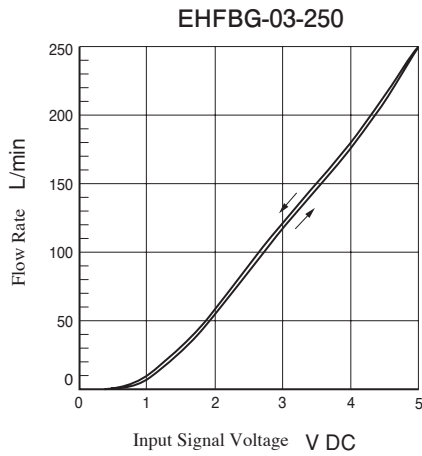

Input Signal Voltage vs. Pressure

Viscosity : 30 mm²/s

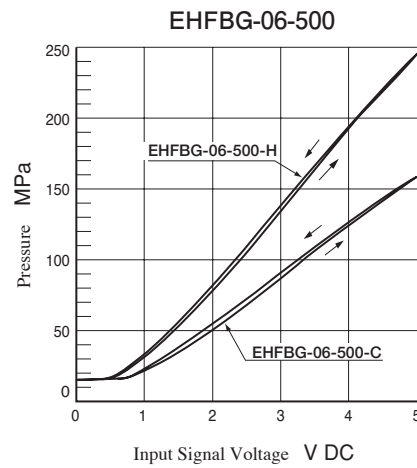
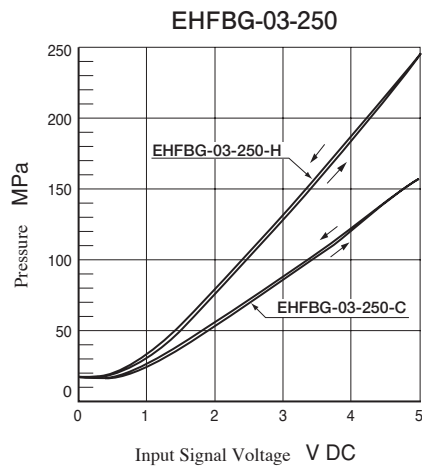

Step Response (Flow Controls)

The step responses below are those obtained when the valve itself is tested independently.
The step responses may differ from them when the valve is used in combination with other control valves.

Viscosity : 30 mm²/s

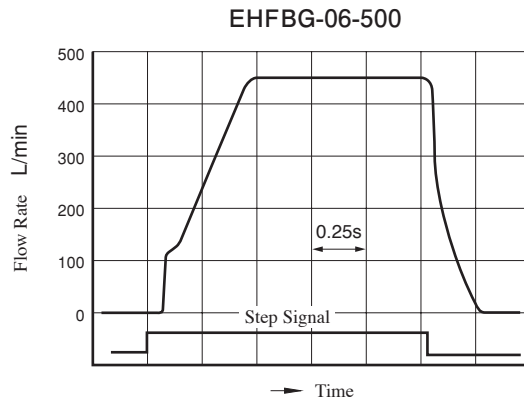
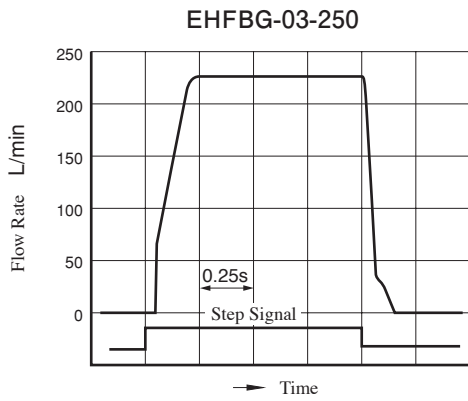

Step Response (Pressure Controls)

The step responses below are those obtained when the valve itself is tested independently.
The step responses may differ from them when the valve is used in combination with other control valves.

Viscosity : 30 mm²/s

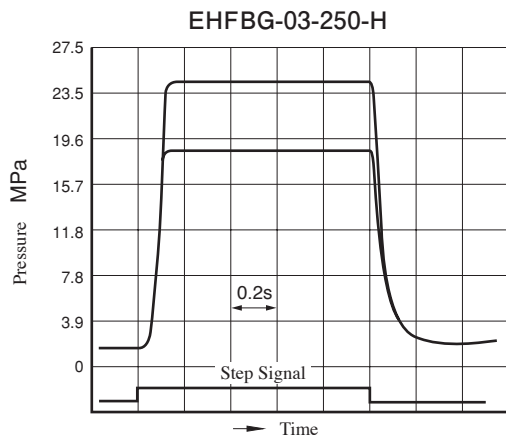

Flow Rate : 250 L/min
Trapped Oil Volume : < 1 L

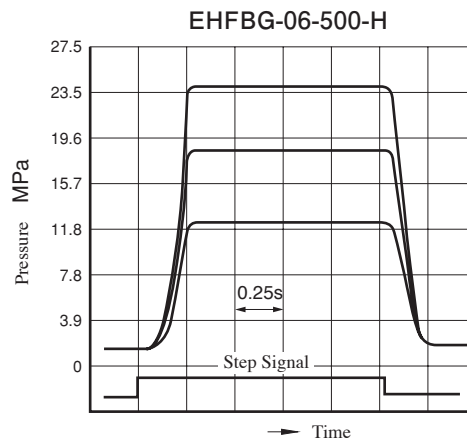

Flow Rate : 500 L/min
Trapped Oil Volume : < 6 L

Proportional Electro-Hydraulic Directional and Flow Control Valves

These valves incorporate two control functions - flow and direction - which simplify the hydraulic circuit composition and therefore the cost of the system is reduced.

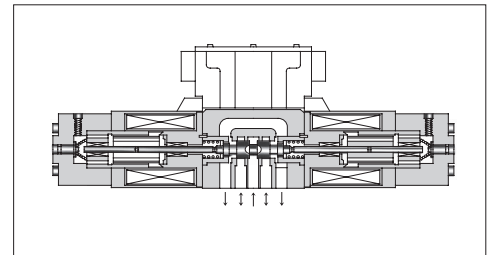
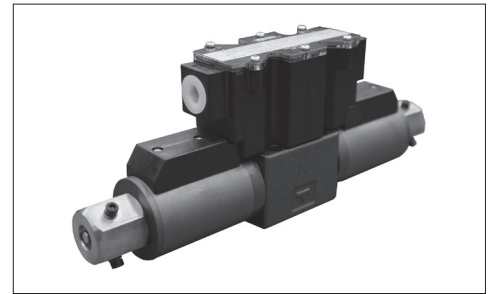

Specifications

Model Numbers		EHDFG-01	EHDFG-03
Descriptions			
Max. Operating Pressure	MPa	25	25
Max. Tank Line Back Pres.	MPa	7	7
Rated Flow [Valve ΔP 7 MPa]	L/min	30	60
Hysteresis		5% or less	
Repeatability		1%* or less	
Frequency Response		20 (Phase: -90°)	17 (Phase: -90°)
Coil Resistance		10.5 Ω	8.0 Ω
Supply Electric Power		24 V DC (21 to 28 V DC Included Ripple)	
Input Signal Voltage	By Controlling Variable Resistance (Using of Power from Amp.)	1 - 2 kΩ Volume Range	
	By Controlling Voltage (Using of Power outside Amp.)	0 - -5 V for SOL a	0 - +5 V for SOL b
Input Impedance		10 kΩ	10 kΩ
Power Input (Max.)		40 W	45 W
Ambient Temperature		0 - 50°C (With Circulated Air)	
Mass		3.0 kg	9.2 kg

* The repeatability of the valves is obtained by having it tested independently on the conditions similar to its original testing.

Graphic Symbols

● Meter-in • Meter-out Control

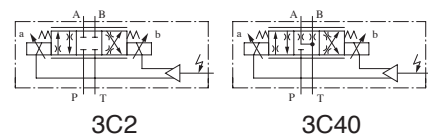

● Meter-out Control

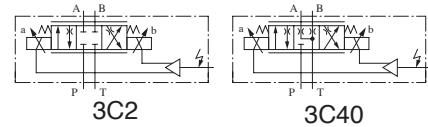

● Meter-in Control

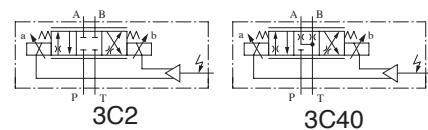

Model Number Designation

EHDF	G	-01	-30	-3C2	-E	-30
Series Number	Type of Mounting	Valve Size	Rated Flow L/min	Spool Type*	Direction of Flow	Design Number
EHDF: Proportional Electro-Hydraulic Directional and Flow Control Valve	G: Sub-Plate Mounting	01	30	3C2	XY : Meter-in • Meter-out X : Meter-in Y : Meter-out	30
		03	60	3C40		30

* 1. Spool type shown under the neutral position.

* 2. Phosphate ester type fluids are also supported. When phosphate ester type fluids are used, prefix "F-" to the model number because the special seals (fluororubber) are required to be used.

Accessories

● **Mounting Bolts**

Model Numbers	Socket Head Cap Screw
EHDFG-01	M5×45 L 4 Pcs.
EHDFG-03	M6×35 L 4 Pcs.

Sub-Plate

Valve Model Numbers	Sub-Plate Model Numbers	Thread Size Rc	Mass kg
EHDFG-01	DSGM-01-31★	1/8	0.8
	DSGM-01X-31★	1/4	
	DSGM-01Y-31★	3/8	
EHDFG-03	DSGM-03-40	3/8	3
	DSGM-03X-40	1/2	
	DSGM-03Y-40	3/4	4.7

● Sub-plates are available. Specify sub-plate model from the table left. When sub-plates are not used, the mounting surface should have a good machined finish. (▽)

★ Refer to Page H-8.

Instructions

Take care of filling the valve tank port with the hydraulic oil at any time. However, check valve with cracking pressure 0.04 MPa approx. shall be provided as required. The pipe from the tank port should be connected to the reservoir directly and the end of the pipe must always be in the oil.

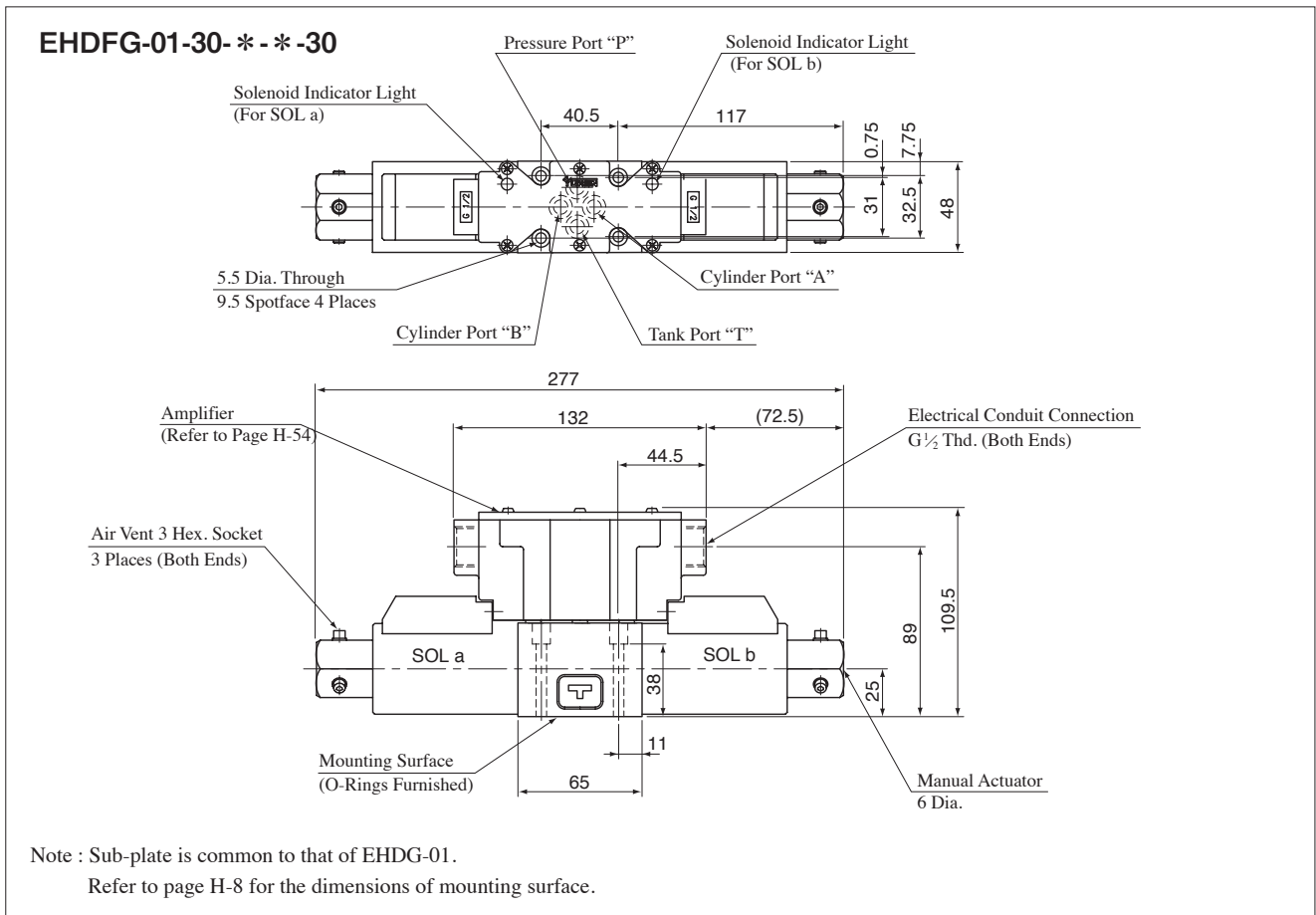

EHDFG-03-60- * - * -30

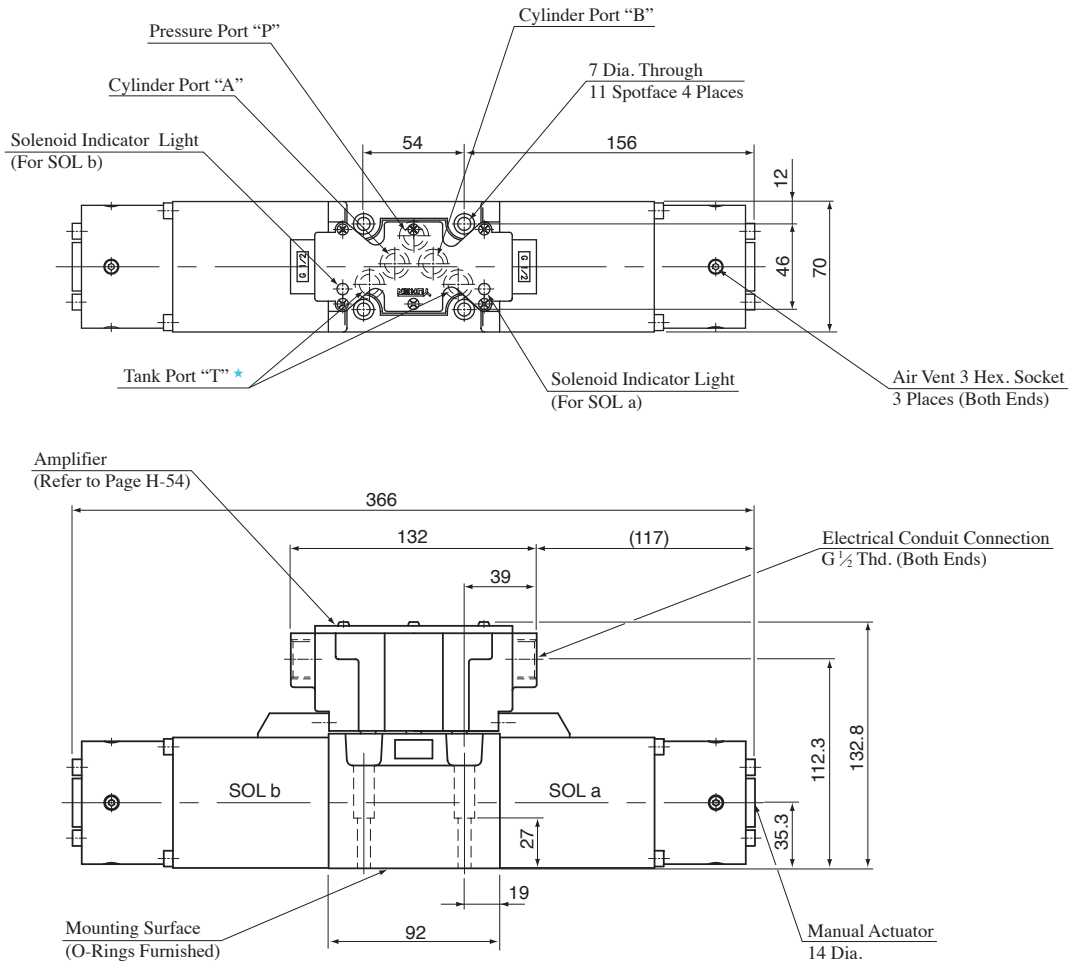

★Of the two of tank port "T", the tank port in the left side is normally used in our standard sub-plate, though, either side of the tank port "T" can be used without problem.

Sub-Plates

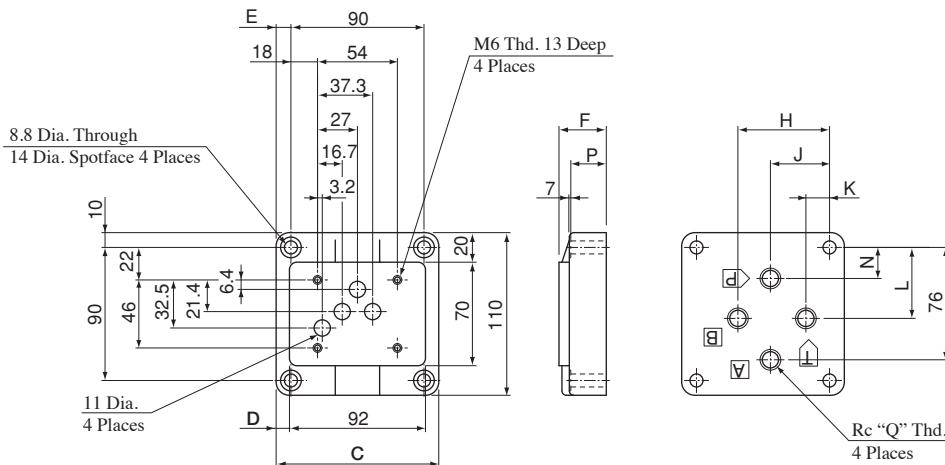

Sub-Plate Model Numbers	C	D	E	F	H	J	K	L	N	P	Q
DSGM-03-40	110	9	10	32	62	40	16	48	21	24	3/8
DSGM-03X-40											1/2
DSGM-03Y-40	120	14	15	50	80	45	10	47	16	42	3/4

Detail of Amplifier

● **Connecting Terminal**

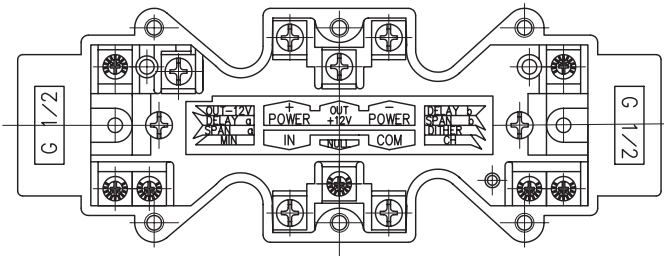

Terminal	Name
POWER +	24V DC Power Supply
POWER -	
IN	Input Signal
COM	Input Signal (COM)
OUT +12V	Internal Voltage Output +12V
OUT -12V	Internal Voltage Output -12V
CH	Output Current Check (to COM)

★1 **DITHER / SPAN / NULL / MIN**

Use as they are since they are factory-preset to the optimum position. (Do not touch them in normal condition.)

★2 **DELAY**

The adjusting volume is set to minimum at shipping. Set a delay time according to the machine conditions.

● **Circuit Schematic**

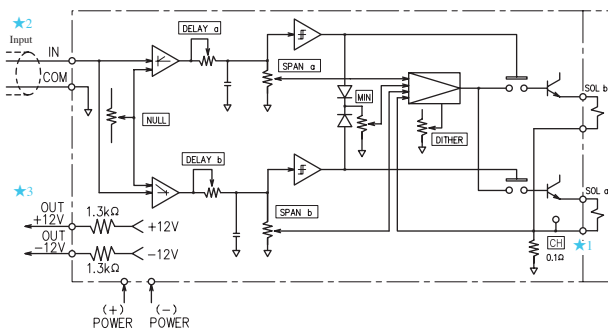

★1. For “CH” terminal, external instruments should have input impedance of more than 10 kΩ.

★2. Use shielded cable for “Input” connection.

The ground of shielded cable must be connected to input signal side.

★3. Internal output voltage ±12V terminal is used when input signal voltage is controlled by variable resistor. Volume of 1 kΩ - 2 kΩ should be used.

Input Signal Voltage vs Flow

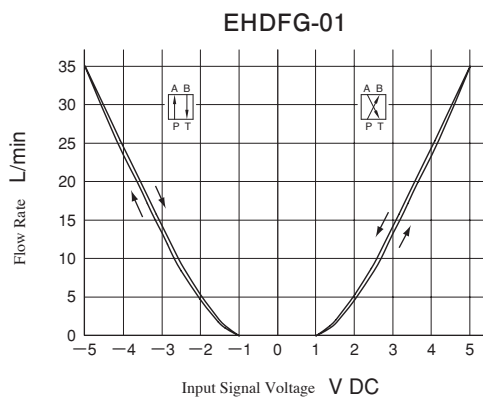

Viscosity : 30 mm²/s
Valve Pres. Difference : 3.4 MPa

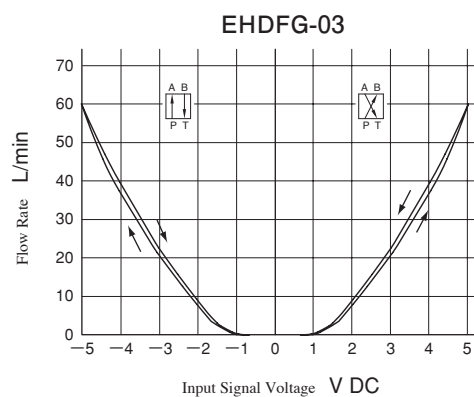

Viscosity : 30 mm²/s
Valve Pres. Difference : 3.4 MPa

Differential Pressure vs. Metered Flow

EHDFG-01-30-*-XY-30

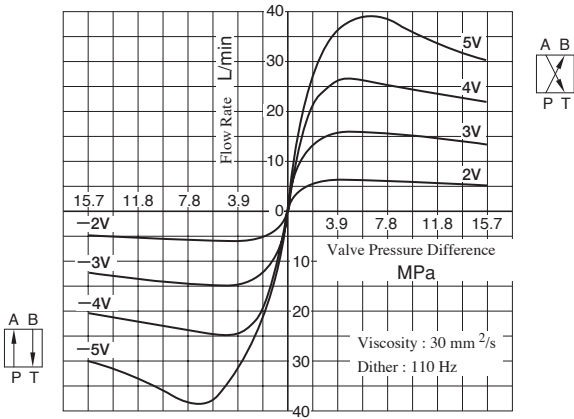

EHDFG-01-30-*-X-30

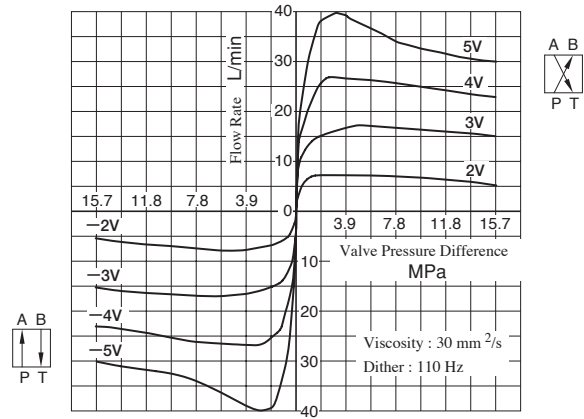

EHDFG-01-30-*-Y-30

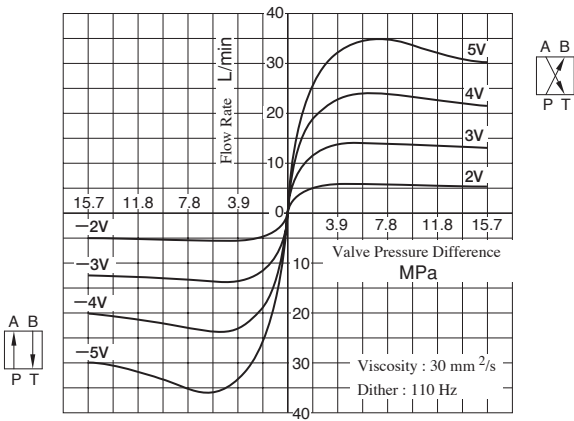

EHDFG-03-60-*-XY-30

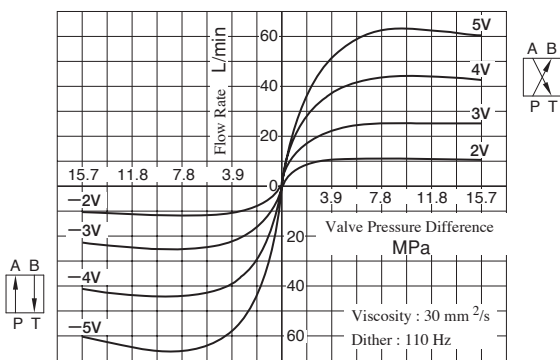

EHDFG-03-60-*-X-30

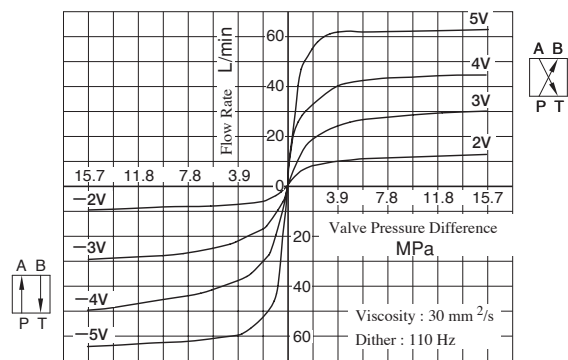

EHDFG-03-60-*-Y-30

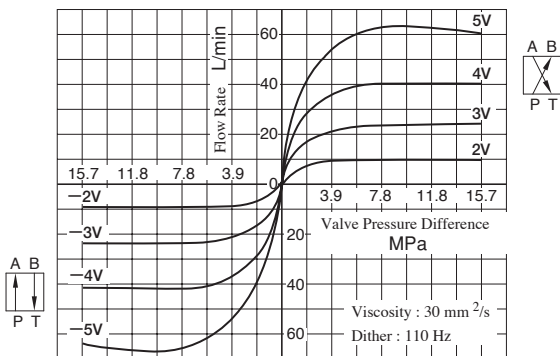

Frequency Response (Travel of Spool)

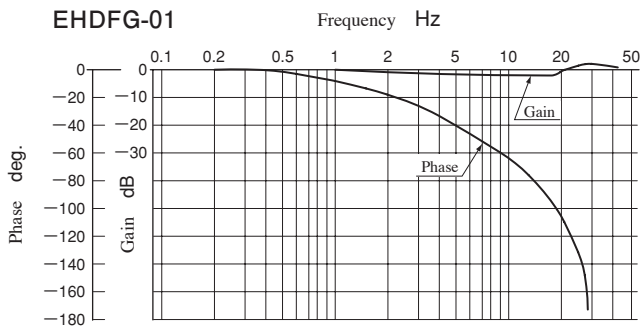

Model Number : EHDFG-01-03- * -Y-30
 Viscosity : 30 mm²/s
 Supply Pressure : 6.9 MPa
 Flow Rate : 15±6 L/min

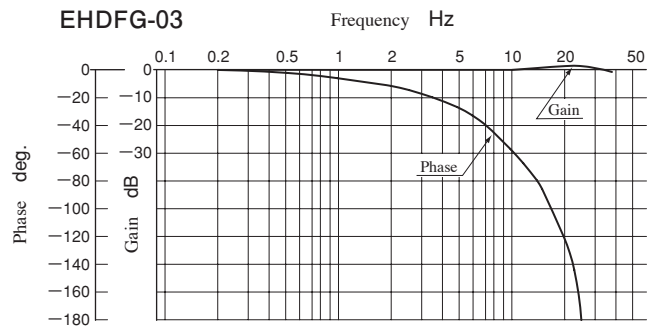

Model Number : EHDFG-03-60- * -Y-30
 Viscosity : 30 mm²/s
 Supply Pressure : 6.9 MPa
 Flow Rate : 30±6 L/min

Step Response (Example)

The step responses below are those obtained when the valve itself is tested independently.
 The step responses may differ from them when the valve is used in combination with other control valves.

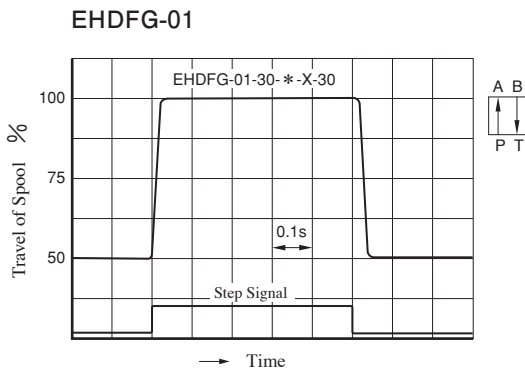

Viscosity : 30 mm²/s
 Supply Pressure : 6.9 MPa

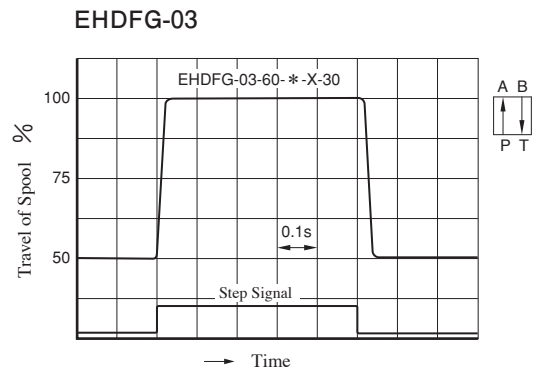

Viscosity : 30 mm²/s
 Supply Pressure : 6.9 MPa

High Response Type Proportional Electro-Hydraulic Directional and Flow Control Valves

These valves pursue the ultimate performance of proportional electro-hydraulic directional & flow control valves and make themselves to have high response features.

The closed-loop is composed in the valve inside by combination of a differential transformer (LVDT) and a power amplifier. Thus, high accuracy and reliability are provided.

In addition to control in the open-loop, these can be used for the closed-loop system as simplified servo valves.

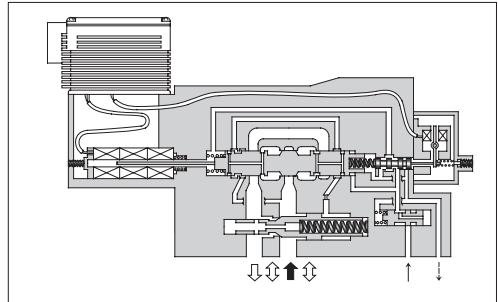
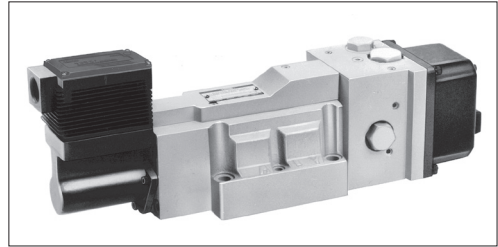

Specifications

Model Numbers		EHDFG-04	EHDFG-06
Descriptions			
Max. Operating Pressure	MPa	15.7	15.7
Rated Flow	L/min	130	280
Valve Pres. Difference: 1.5 MPa			
Min. Required Pilot Pressure	MPa	1.5	1.5
Min. Required Pilot Flow	at Normal	2	2
	at Transition	6	10
Max. Drain Line Back Pressure	MPa	0.1	0.1
Hysteresis		1% or less	
Repeatability		1%* or less	
Frequency Response		55	45
		(Phase: -90°)	(Phase: -90°)
Coil Resistance		30 Ω	
Supply Electric Power		24 V DC (21 to 28 V DC Included Ripple)	
Input Signal Voltage		Rated Flow / 5 V DC	
Input Impedance		10 kΩ	
Power Input (Max.)		20 W	
Alarm Signal Output (Open Collector)		Voltage: Max. 30 V DC Current: Max. 30 mA	
LVDT Output (Sensor Monitor)		5 V DC / Rated Travel of Spool	
Ambient Temperature		0 - 50°C (With Circulated Air)	

*The repeatability of the valves is obtained by having it tested independently on the conditions similar to its original testing.

Graphic Symbols

- Models without Pressure Compensator Valve

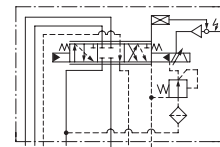

Internal Pilot

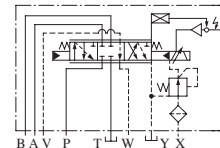

External Pilot

- Models with Pressure Compensator Valve

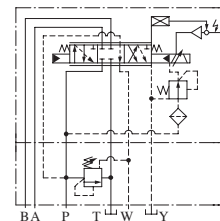

Internal Pilot

Model Number Designation

EHDF	G	-04	-130	-2	-E	-CB	-10
Series Number	Type of Mounting	Valve Size	Rated Flow L/min	Spool Type*	Pilot Connection	Relief Type Pres. Compensator	Design Number
EHDF: Proportional Electro-Hydraulic Directional and Flow Control Valve	G: Sub-Plate Mounting	04	130	2	None: Internal Pilot	None: Not Provided	10
		06	280	40	E: External Pilot	CB: Provided	10

*1. Spool type shown in the column is for the neutral position.

*2. Phosphate ester type fluids are also supported. When phosphate ester type fluids are used, prefix "F-" to the model number because the special seals (fluororubber) are required to be used.

Accessories

● **Mounting Bolts**

Model Numbers	Socket Head Cap Screw		Q'ty
	Models without Pres. Compensator	Models with Pres. Compensator	
EHDFG-04	M6 × 40 L	M6 × 120 L	2
	M10 × 45 L	M10 × 125 L	4
EHDFG-06	M12 × 60 L	—	6
	—	Mtg. Bolt Kit MBK-06-01-30	1 Set

Sub-Plate

Valve Model Numbers	Sub-Plate Model Numbers	Thread Size Rc	Mass kg
EHDFG-04	DHGM-04-20	1/2	4.4
	DHGM-04X-20	3/4	4.1
EHDFG-06	DHGM-06-50	3/4	7.4
	DHGM-06X-50	1	

● Sub-plates are available. Specify sub-plate model from the table above. When sub-plates are not used, the mounting surface should have a good machined finish. (1/8)

Instructions

● **Back Pressure to Drain Port**

The drain port should be connected directly to the oil tank with a back pressure of not more than 0.1 MPa.

● **Installation Condition (Protection from Magnetic Field of DC SOL)**

If a DC SOL is installed near this valve, the magnetic field of DC SOL may affect the control flow rate. Therefore, install the DC SOL outside the area shown below.

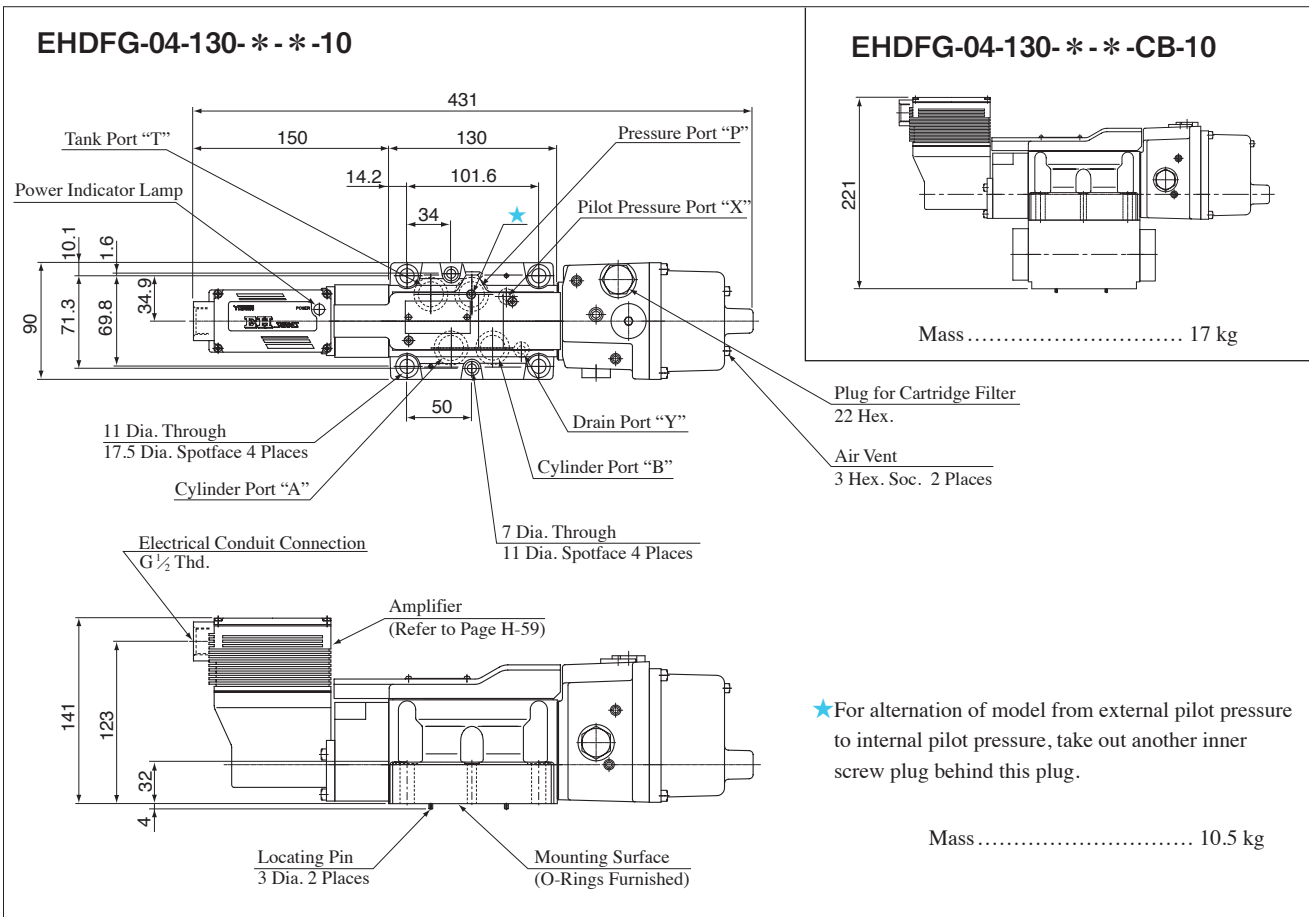
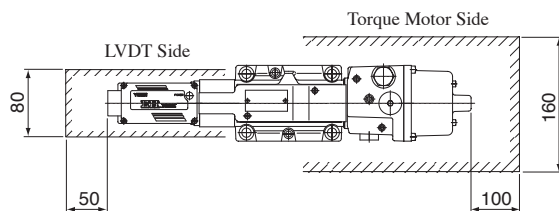

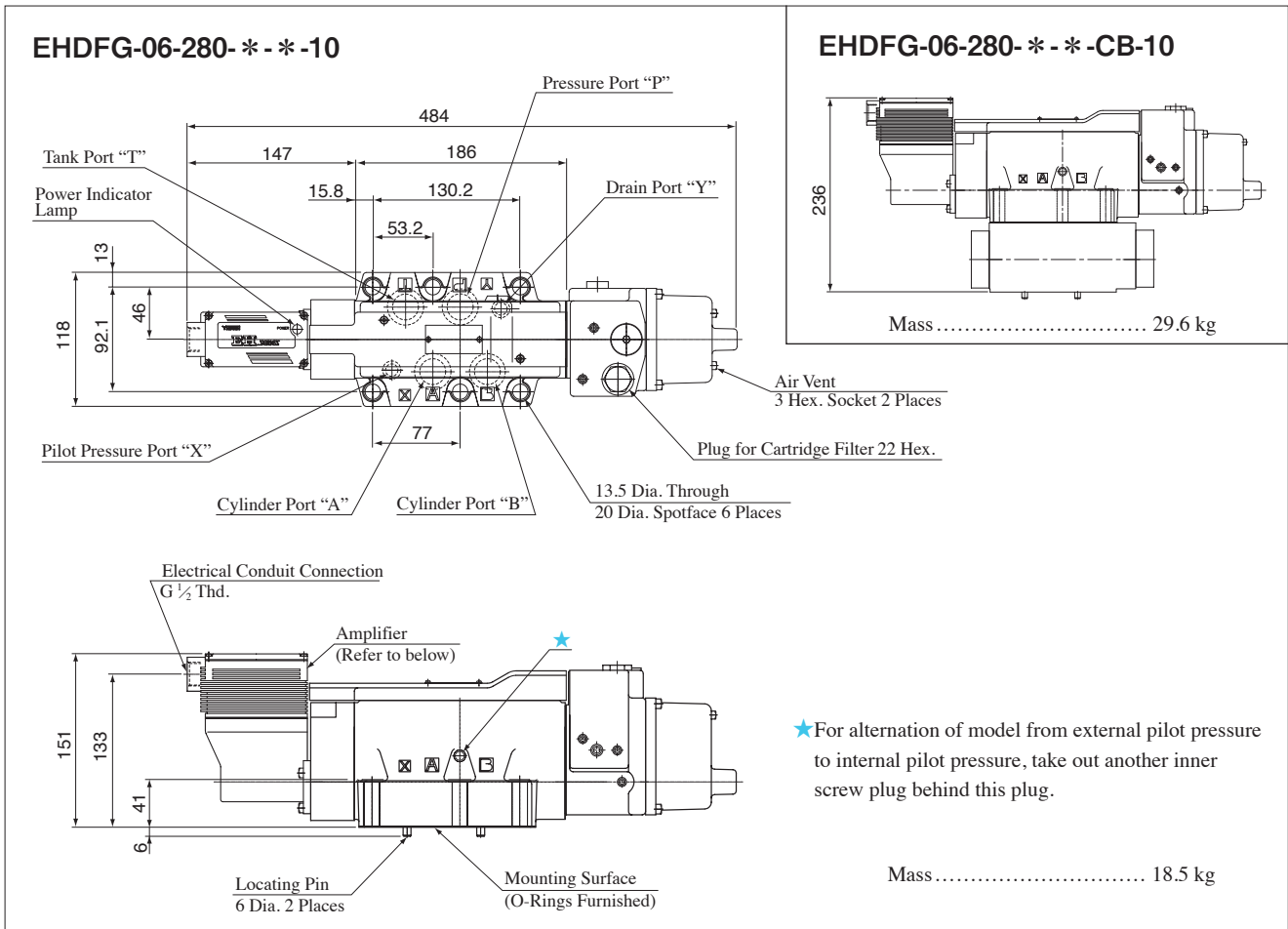

Detail of Amplifier

● Connecting Terminal

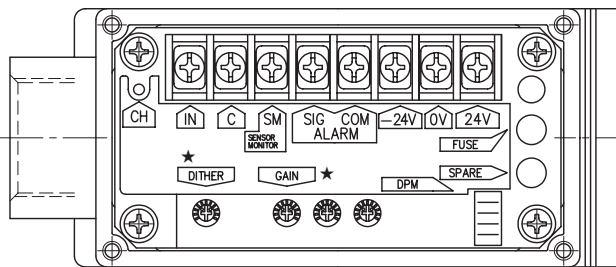

Terminal	Name
IN	Input Signal (±)
C	Input Signal (COM)
SM	Sensor Monitor (to C)
ALARM	Alarm Output
SIG	
COM	Power Supply
-24V	
0V	
24V	Output Current Check (to C)
CH	

★ DITHER / GAIN

Use as they are since they are factory-preset to the optimum position.
(Do not touch them in normal condition.)

● Circuit Schematic

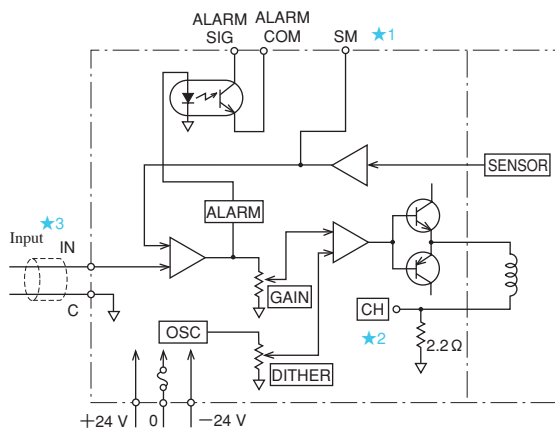

- ★1. For "SM" terminal, external instruments should have input impedance of more than 10 kΩ.
- ★2. For "CH" terminal, external instruments should have input impedance of more than 10 kΩ.
- ★3. Use shielded cable for "Input" connection.
The ground of shielded cable must be connected to input signal side.

Sub-Plate

DHGM-04, 04X

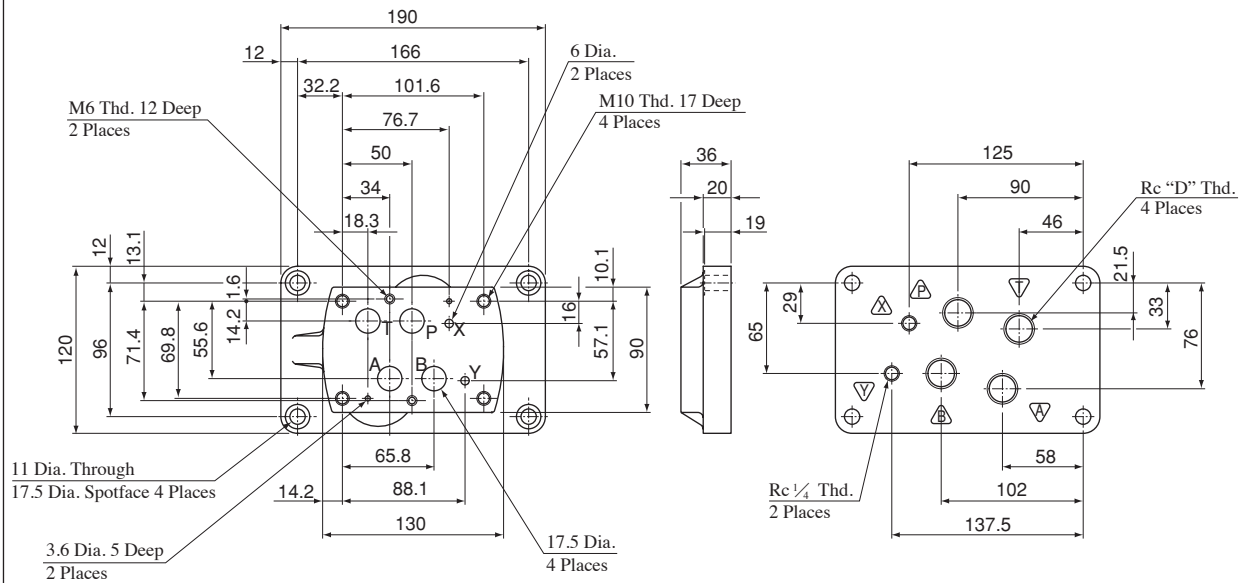

Model Numbers	D
DHGM-04-20	1/2
DHGM-04X-20	3/4

DHGM-06, 06X

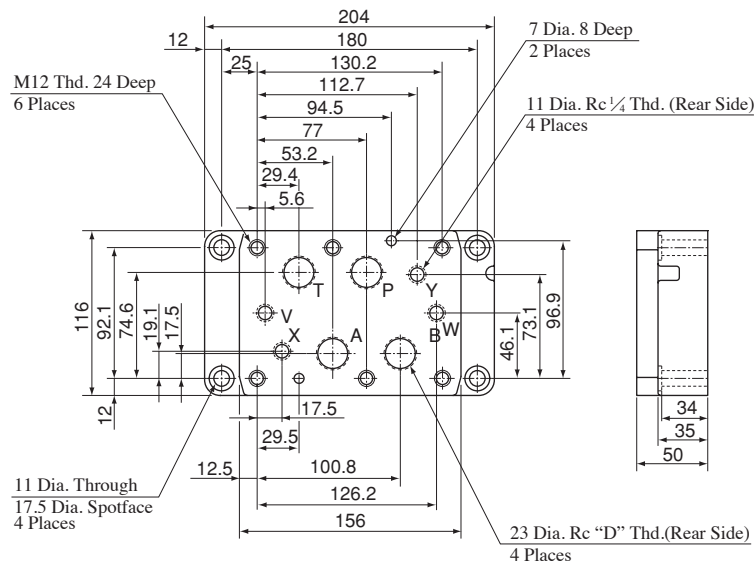

Model Numbers	D
DHGM-06-50	3/4
DHGM-06X-50	1

Input Signal Voltage vs. Flow

Viscosity : 30 mm²/s
Valve Pressure Difference : 1.5 MPa Const.

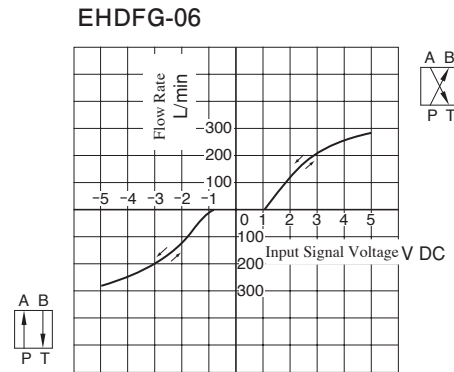
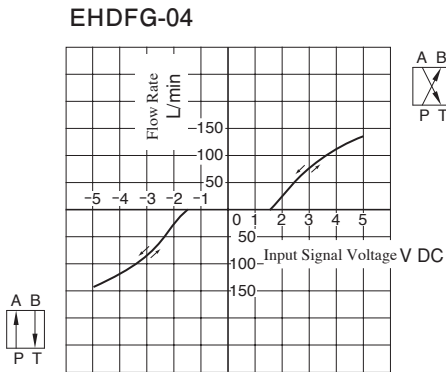

Differential Pressure vs. Metered Flow

Viscosity : 30 mm²/s

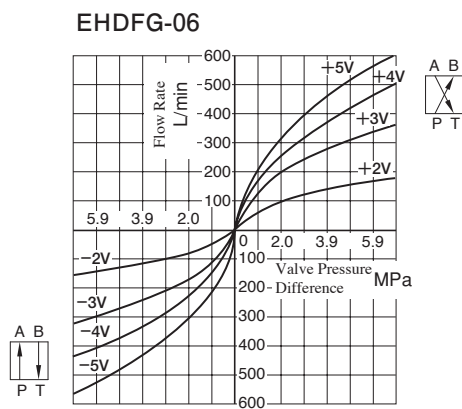
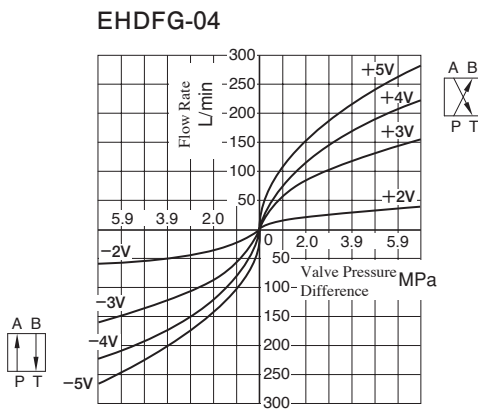

Frequency Response (Travel of Spool)

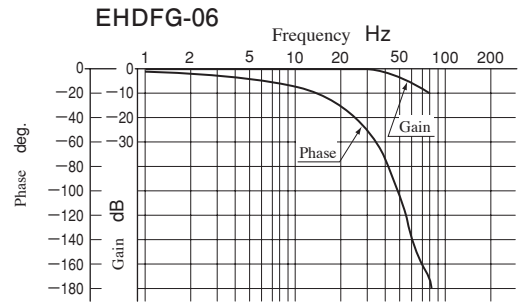
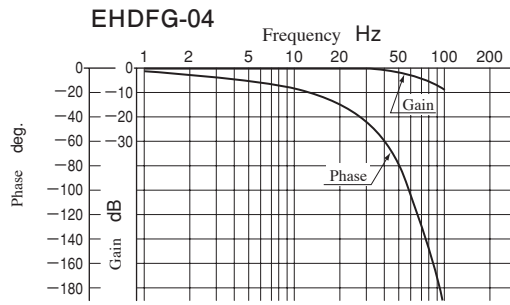

Model Number : EHDFG-04-130-2-E-10
Viscosity : 30 mm²/s
Pilot Pressure : 15.7 MPa
Travel of Spool : ±10% of Rated Travel

Model Number : EHDFG-06-280-2-E-10
Viscosity : 30 mm²/s
Pilot Pressure : 15.7 MPa
Travel of Spool : ±10% of Rated Travel

Step Response

The step responses below are those obtained when the valve itself is tested independently.
The step responses may differ from them when the valve is used in combination with other control valves.

