

High Response Type Proportional Electro-Hydraulic Directional and Flow Control Valves

High response, high precision and high reliability are achieved by a combination of a compact and powerful solenoid and a spool-position-detection LVDT.

Direct type ELDFG-01/03 and two stage type ELDFG-04/06 (which use the ELDFG-01 as a pilot) are available.

Direct Operated Type Directional and Flow Control Valves

This product can be interchanged with the simplified servo valve to perform position control and pressure control.

Compared to nozzle flapper type servo valve, this product has excellent contamination-related problems.

Specifications

Model No.		ELDFG-01	ELDFG-03
Descriptions			
Max. Operating Pressure	MPa	31.5	
Max. Tank Line Back Pressure	MPa	21	
Rated Flow	L/min	10: 10	40: 40
Valve Pres. Diff. : 1.5 MPa		20: 20	80: 80
		35: 35	
Hysteresis		0.5% or less	
Repeatability		0.5% or less	
Step Response (Typical Rating)	0 → 100%	30 ms	3C2, 3C40: 29 ms 3C2P: 25 ms
	100 → 0%	—	3C2, 3C40: 26 ms 3C2P: 23 ms
Frequency Response (0 ± 25 %V)	Phase -90 degree	48 Hz	3C2, 3C40: 36 Hz 3C2P: 41 Hz
	Gain -3 dB	52 Hz	3C2, 3C40: 35 Hz 3C2P: 38 Hz
Rated Current	A	Max. 2.5	Max. 3
Coil Resistance [20°C]	Ω	3.9	3
Power Input	W	Max. 25	Max. 27
Approx. Mass	kg	3.2	7.5

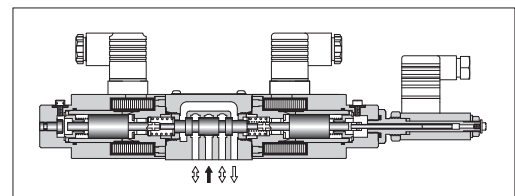
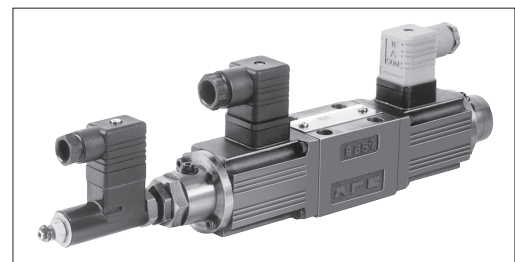

Graphic Symbols

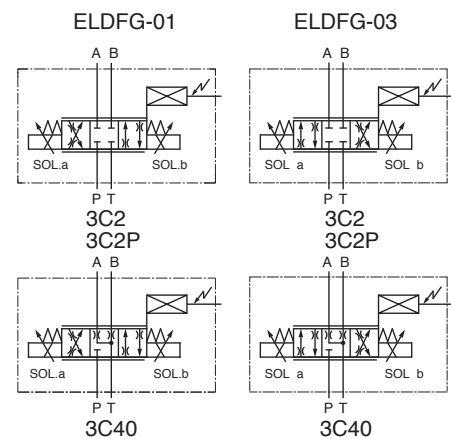

Range of Flow Control

See “Valve Pres. Difference vs. Flow Rate” below characteristics for the appropriate range.

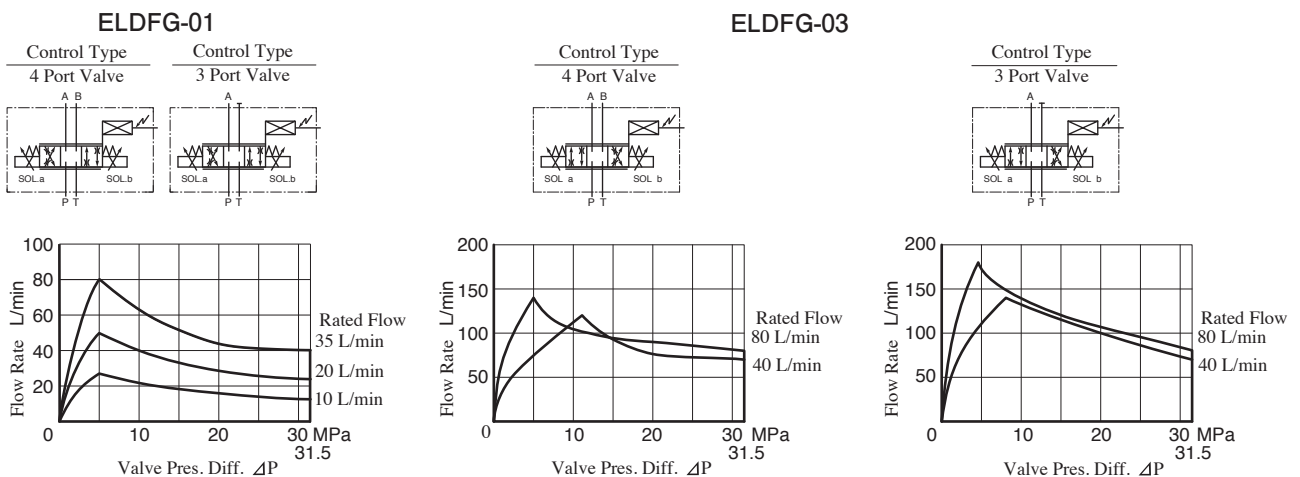

★ Valve pressure difference “ΔP” is reference by follows. In addition, “P”, “A”, “B”, “T”, are pressure of each port.
 4 Port Valve: $\Delta P = [(P-A) + (B-T)]$ or $[(P-B) + (A-T)]$
 3 Port Valve: $\Delta P = (P-A)$ or $(A-T)$

Model Number Designation

ELDF	G	-01	-35	-3C2	-XY	-10
Series Number	Type of Mounting	Valve Size	Rated Flow L/min	Spool Type	Direction of Flow	Design Number
ELDF: High Response (Direct) Type Proportional Electro-Hydraulic Directional and Flow Control Valves	G: Sub-Plate Mounting	01	10 20 35		XY: Meter-in Meter-out	10
		03	40 80			10

Accessories

Mounting Bolts

Four socket head cap screws in the table below are included.

Model No.	Socket Head Cap Screw	Qty.	Tightening Torque
ELDFG-01	M5 × 45 L	4	5 - 7 Nm [Applicable to working pressure more than 25 MPa: 6 - 7 Nm]
ELDFG-03	M6 × 35 L	4	12 - 15 Nm

Sub-Plate

Valve Model Numbers	Sub-Plate Model Numbers	Thread Size Rc	Approx. Mass kg
ELDFG-01	DSGM-01-31	1/8	0.8
	DSGM-01X-31	1/4	
	DSGM-01Y-31	3/8	
ELDFG-03	DSGM-03-40	3/8	3.0
	DSGM-03X-40	1/2	
	DSGM-03Y-40	3/4	4.7

- Sub-plates are available. Specify the sub-plate model number from the table above. When sub-plates are not used, the mounting surface should have a good machined finish. (1/6)
- The Sub-plates are those for 1/8 and 3/8 solenoid operated directional valves. For dimensions, see pages H-8 and H-53.

Applicable Power Amplifiers

For stable performance, it is recommended that Yuken's applicable power amplifiers be used (for details see page H-190).

Valve Model Numbers	Power Amplifier Model Numbers
ELDFG-01- * 3C2 3C40	AMN-L-01-1-10 AMB-EL-01-★- * -20
ELDFG-01- * 3C2P	AMN-L-01-3-2P-10 AMB-EL-01-2P-★- * -20
ELDFG-03- * 3C2 3C40	AMB-EL-03-1- * -20
ELDFG-03- * 3C2P	AMB-EL-03-2P-1- * -20

Instructions

During piping work, special care should be taken so that the tank port “T” is constantly filled with hydraulic fluid. Because back pressure is applied, using a check valve whose cracking pressure is about 0.04 MPa is recommended. Also, connect the tank port piping directly to the oil tank, but do not connect it other piping. For this reason, be sure to immerse the pipe end in fluid.

ELDFG-01--**-XY-10**

Mounting Surface: Conform to ISO4401-03-02-0-05

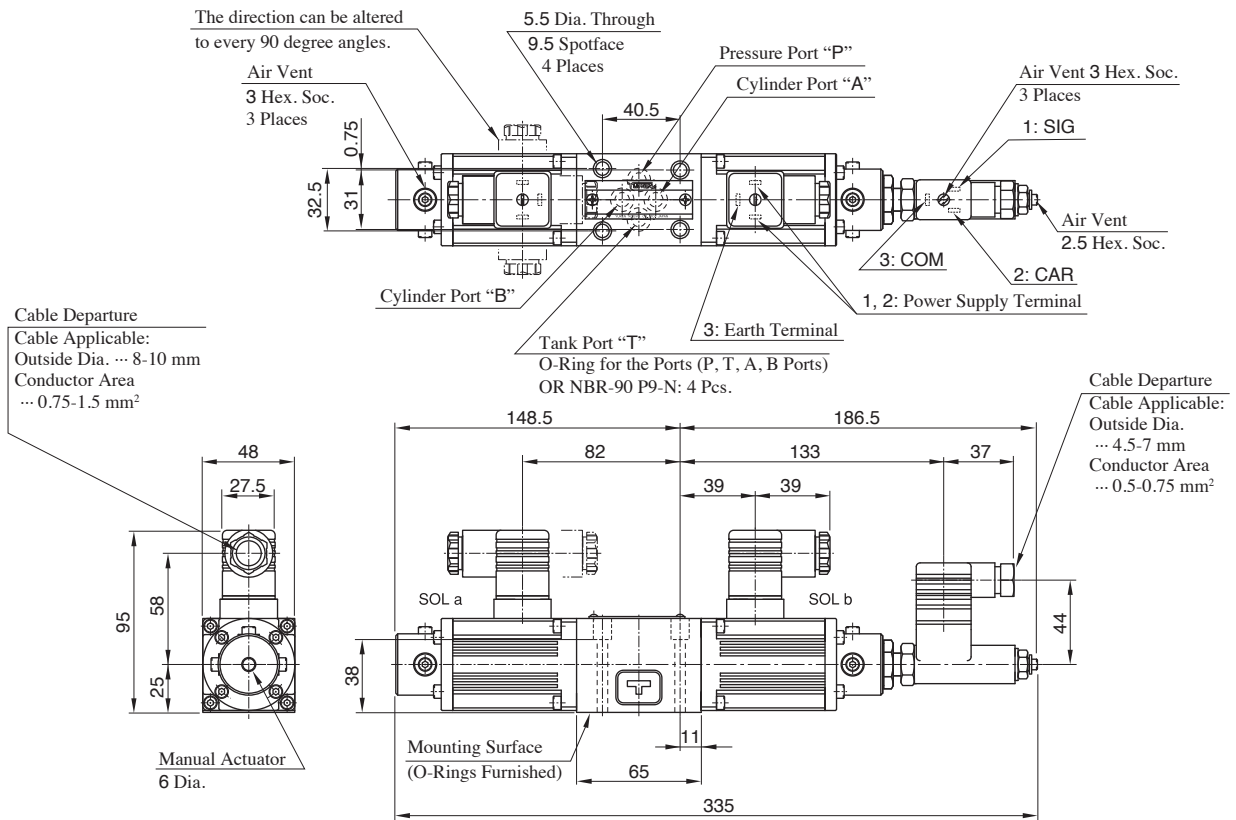

Note) For valve mounting surface dimensions, see the dimensional drawings of sub-plates (page H-8) in common use.

ELDFG-03--**-XY-10**

Mounting Surface: Conform to ISO4401-05-04-0-05

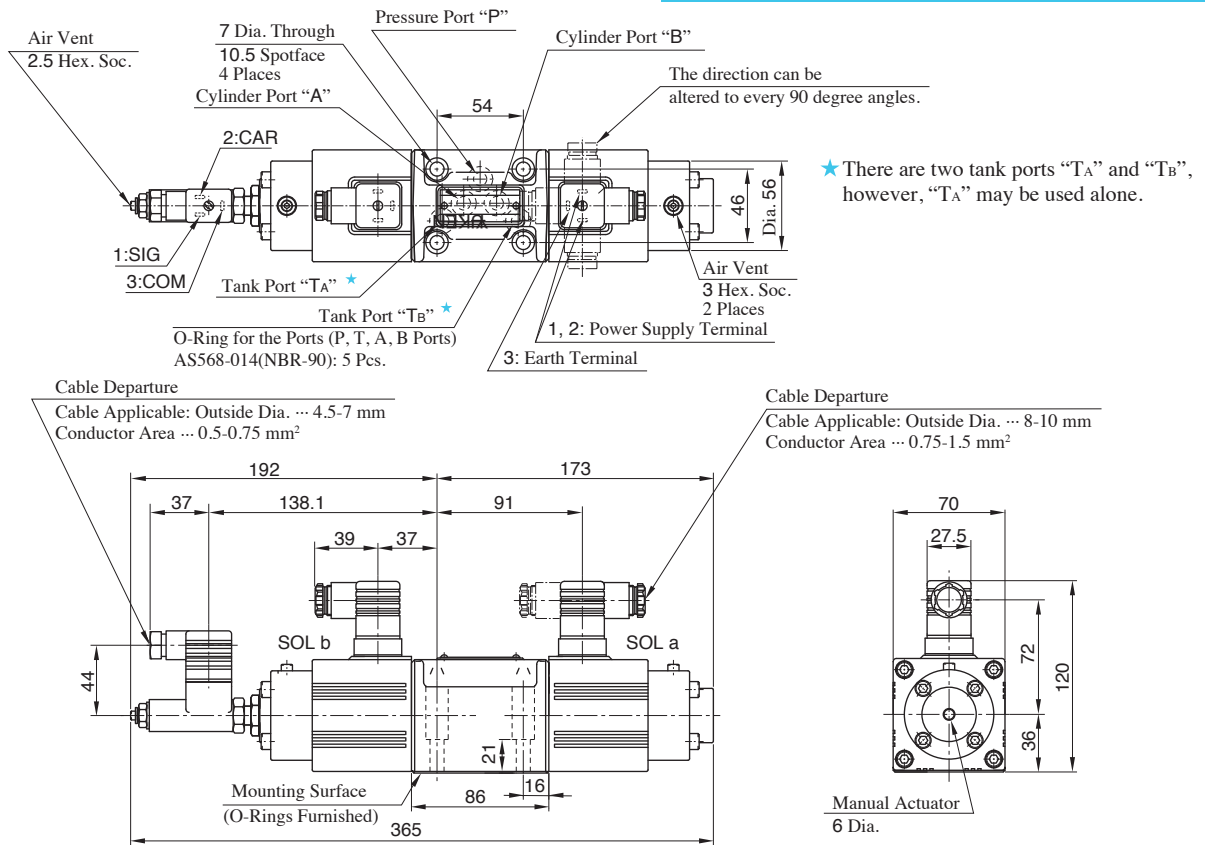

★ There are two tank ports "TA" and "TB", however, "TA" may be used alone.

Note) For valve mounting surface dimensions, see the dimensional drawings of sub-plates (page H-53) in common use.

Input Voltage vs. Flow Rate

ELDFG-01--3C2/3C40**

Valve Pres. Diff. : 1.2 MPa
Viscosity : 30 mm²/s

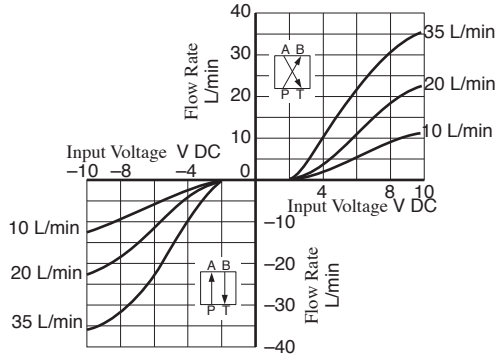

ELDFG-01--3C2P**

Valve Pres. Diff. : 1.2 MPa
Viscosity : 30 mm²/s

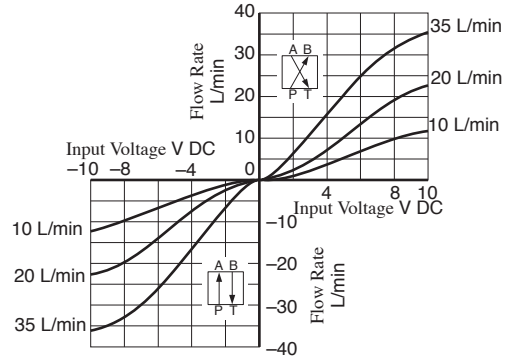

ELDFG-03--3C2/3C40**

Valve Pres. Diff. : 1.5 MPa
Viscosity : 30 mm²/s

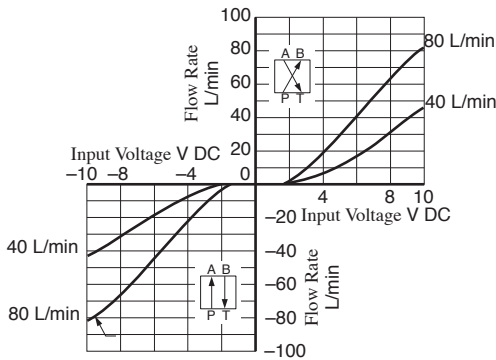

ELDFG-03--3C2P**

Valve Pres. Diff. : 1.5 MPa
Viscosity : 30 mm²/s

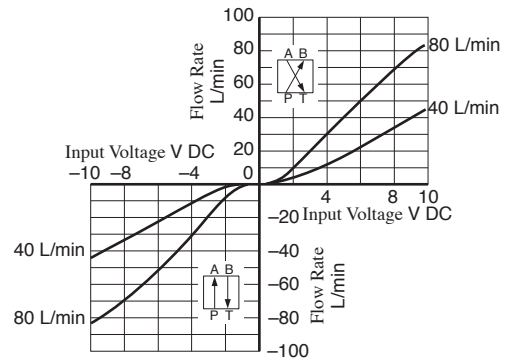

Input Voltage vs. Spool St.

ELDFG-01--3C2/3C40**

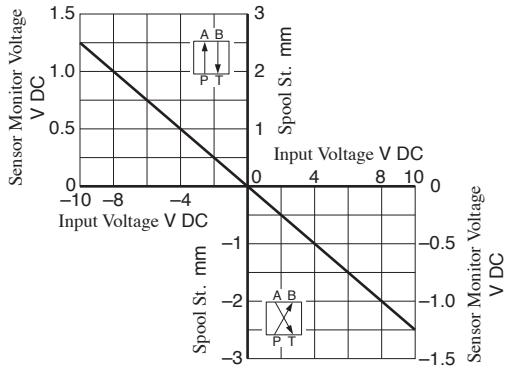

ELDFG-01--3C2P**

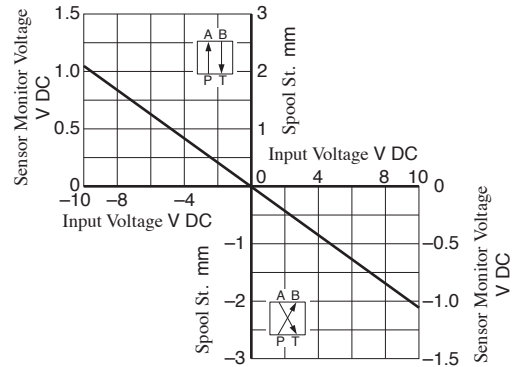

ELDFG-03--3C2/3C40**

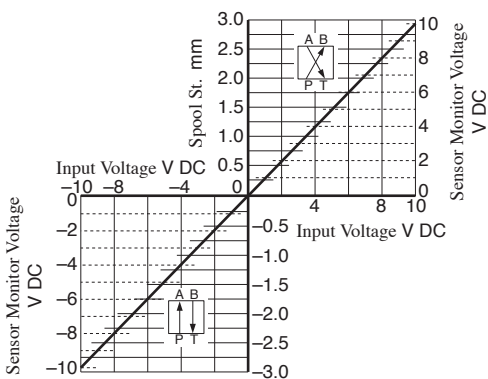

ELDFG-03--3C2P**

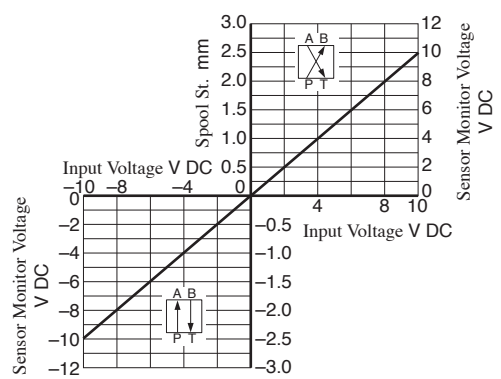

Step Response (Example)

Viscosity : 30 mm²/s

The values were measured on independent valves. They vary by circuit.

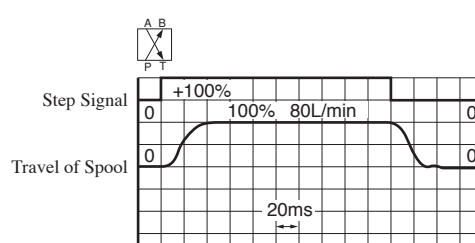
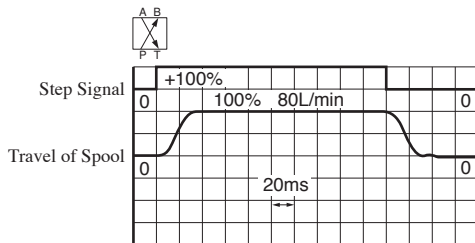
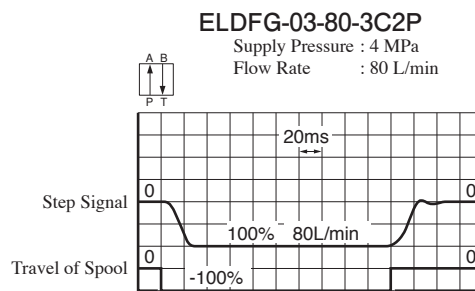
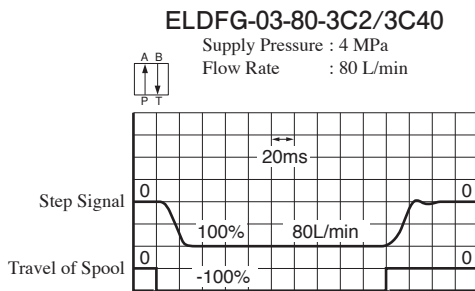
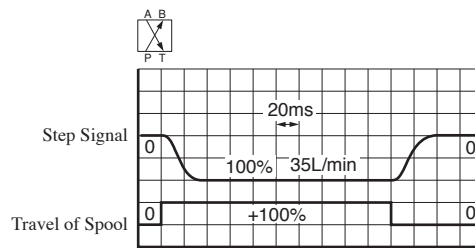
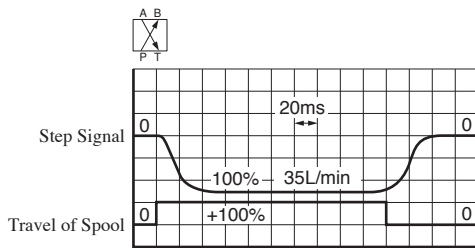
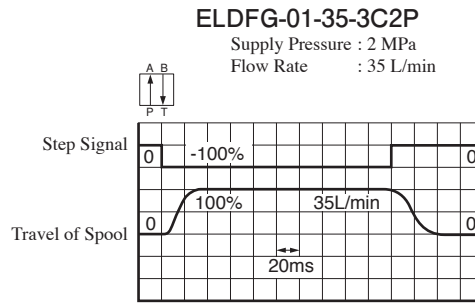
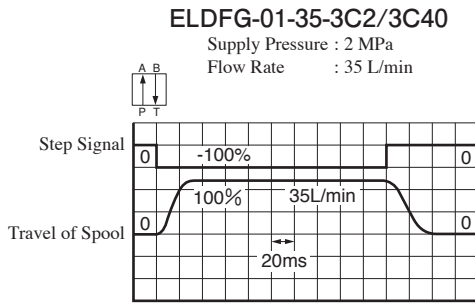

Frequency Response

Input Signal : 0 ± 25 %V
 Primary Pressure : 14 PMA
 Viscosity : 30 mm²/s

ELDFG-01-35-3C2/3C40/3C2P

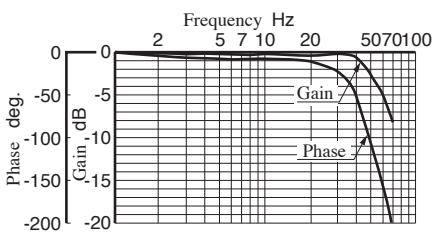

ELDFG-03-80-3C2/3C40

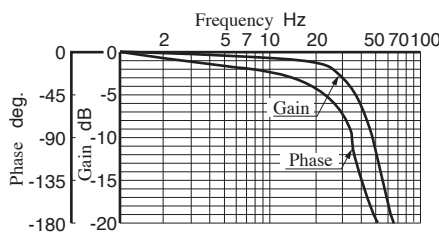

ELDFG-03-80-3C2P

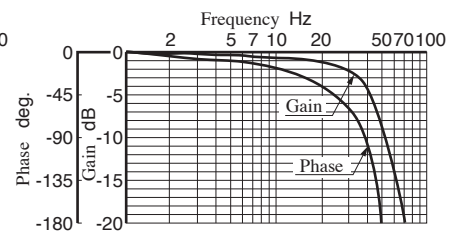

Two Stage Type Directional and Flow Control Valves

Specifications

Descriptions	Model No.	ELDFHG-04	ELDFHG-06
Rated Flow Valve Pres. Diff. : 1 MPa	L/min	280	350 500
Max. Operating Pressure	MPa	35	350: 35 500: 31.5
Proof Pressure at Return Port (External Drain)	MPa	"T" Port : 31.5 "Y" Port : 21	350 "T" Port : 35 "Y" Port : 21 500 "T" Port : 25 "Y" Port : 21
Proof Pressure at Return Port (Internal Drain)	MPa	21	
Pilot Pressure	MPa	1.5-31.5	
Pilot Flow		16 L/min or more	350: 16 L/min or more 500: 19 L/min or more
Null Leakage	Ps=14 MPa, Pp=14 MPa	3C2: 3 L/min or less 3C2P: 10 L/min or less	3C40: 4 L/min or less
Step Response (Typical Rating) (0↔100%)	Pp=14 MPa	13 ms	350: 15 ms 500: 18 ms
Frequency Response (0±25%V, Phase)	Pp=14 MPa	46 Hz (-90 degree)	350: 40 Hz (-90 degree) 500: 39 Hz (-90 degree)
Water - Proofness		IP64	
Operating Temperature Range		-15 - +60 °C	
Spool Type		3C2: 3C2P: 3C40:	
Approximate Spool Stroke to Stops		±5 mm	350: ±5 mm 500: ±7 mm
Main Spool End Area	cm ²	7.1	8
Rated Current	A	Max. 2.5	
Coil Resistance [20 °C]	Ω	3.9	
Approx. Mass	kg	10	350: 18 500: 19

- ★ 1. Return pressure should be less than the actual supply pressure.
- ★ 2. Pilot pressure should be between 1.5 MPa and 31.5 MPa, and should exceed 60% of the actual supply pressure to main valve.
- ★ 3. Pilot flow is calculated with the above step response time at pilot pressure 14 MPa.
- ★ 4. Added up leakage of main and pilot spools are stated.

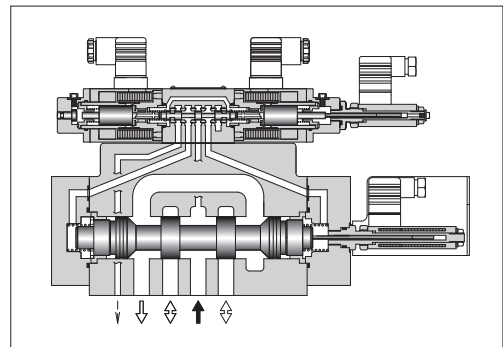
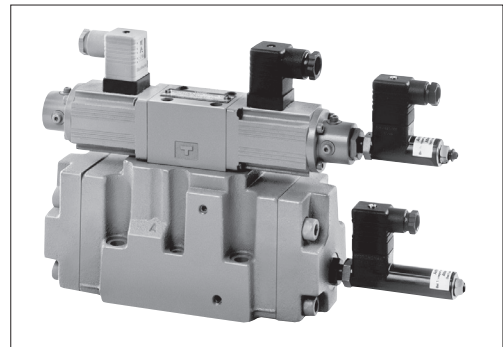

Graphic Symbols

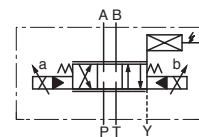

Internal Pilot /
External Drain Type

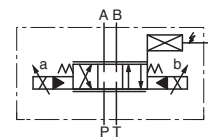

Internal Pilot /
Internal Drain Type

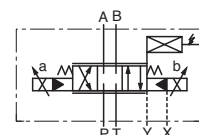

External Pilot /
External Drain Type

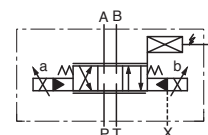

External Pilot /
Internal Drain Type

Model Number Designation

ELDFH	G	-04	-280	-3C2P	-XY	-E	T	-10
Series Number	Type of Mounting	Valve Size	Rated Flow L/min	Spool Type	Direction of Flow	Pilot Connection	Drain Connection	Design Number
ELDFH: High Response (Two Stage) Type Proportional Electro-Hydraulic Directional and Flow Control Valves	G: Sub-Plate Mounting	04	280	3C2 3C40	XY : Meter-in Meter-out	None: Internal Pilot	None: External Drain	10
		06	350 500	3C2P		E: External Pilot	T: Internal Drain	10

Applicable Power Amplifiers

For stable performance, it is recommended that Yuken's applicable power amplifiers be used (for details see page H-190).

Model Numbers	Power Amplifier Model Numbers
ELDFHG-04-280- ^{3C2} / _{3C40}	AMB-EL-04-2- *-20
ELDFHG-04-280-3C2P	AMB-EL-04-2P-2- *-20
ELDFHG-06-350- ^{3C2} / _{3C40}	AMB-EL-06-3- *-20
ELDFHG-06-350-3C2P	AMB-EL-06-2P-3- *-20
ELDFHG-06-500- ^{3C2} / _{3C40}	AMB-EL-06-4- *-20
ELDFHG-06-500-3C2P	AMB-EL-06-2P-4- *-20

Accessories

Mounting Bolts

Model Numbers	Socket Head Cap Screw	Qty.
ELDFHG-04	M6 × 55 L	2
	M10 × 60 L	4
ELDFHG-06	M12 × 85 L	6

ELDFHG-04-280- *-XY- *- *-10

Mounting Surface: Conform to ISO4401-07-07-0-05

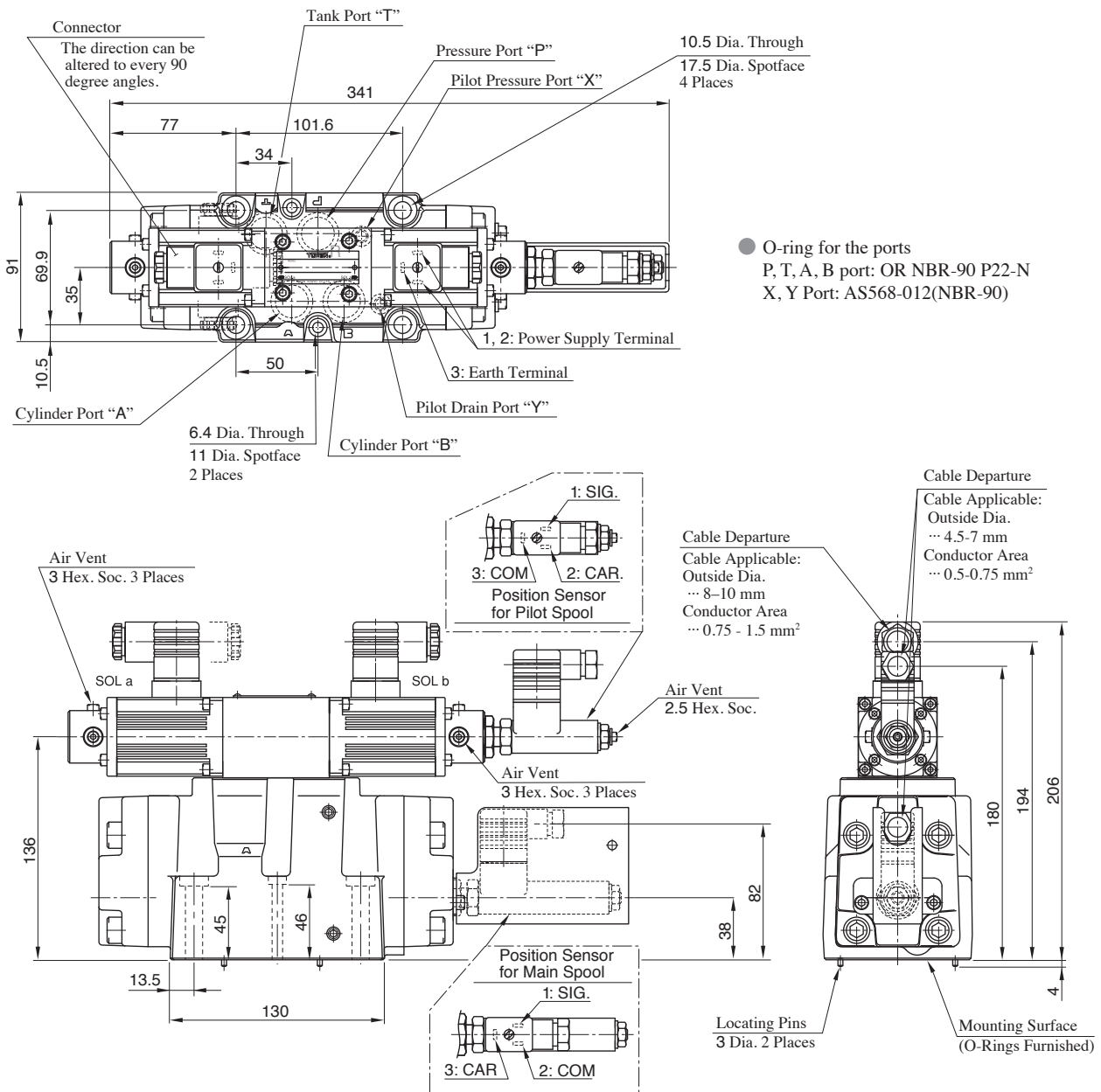

Note) For valve mounting surface dimensions, refer to page H-170.

ELDFHG-06-*-*-XY-*-*-10

Mounting Surface: Conform to ISO4401-08-08-0-05

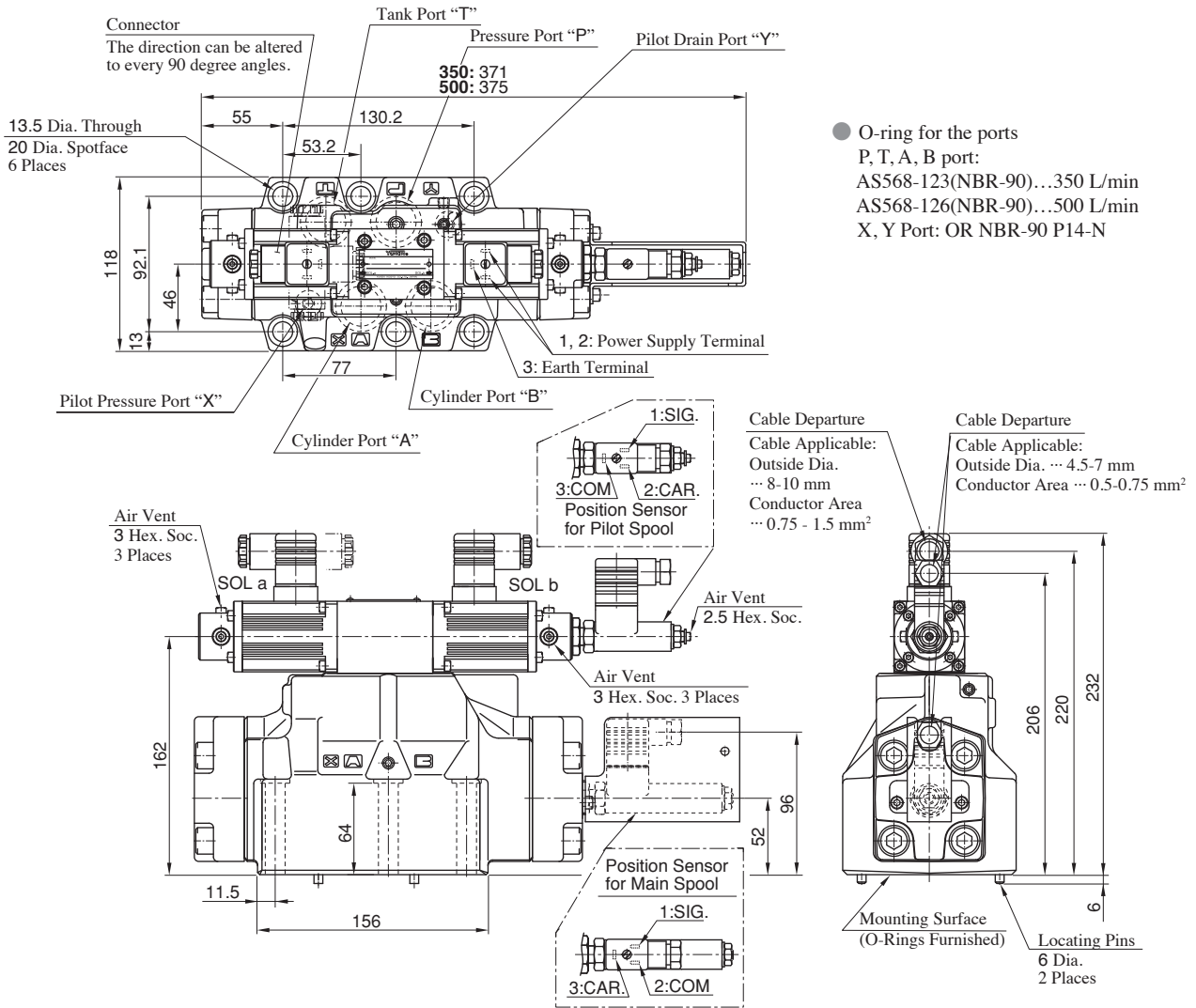

Dimensions of Valve Mounting Surface

Prepare a mounting surface as shown to the below.
Also finish it finely.

● **ELDFHG-04**

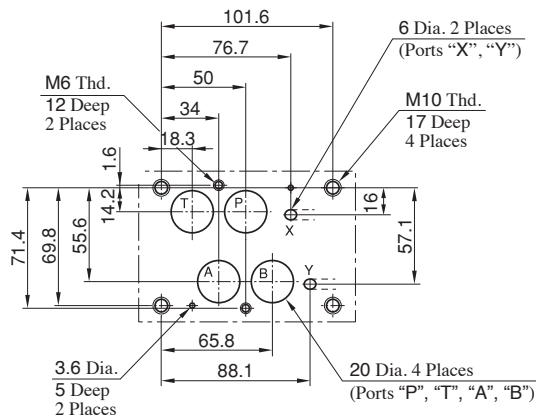

● **ELDFHG-06**

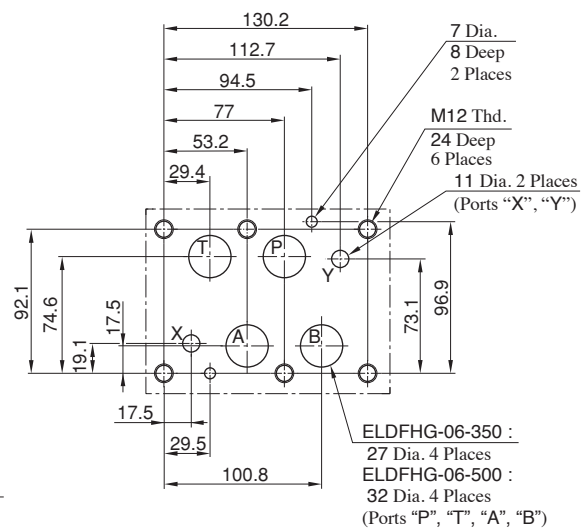

Input Voltage vs. Flow Rate

Valve Pres. Diff. : 1 MPa
Viscosity : 30 mm²/s

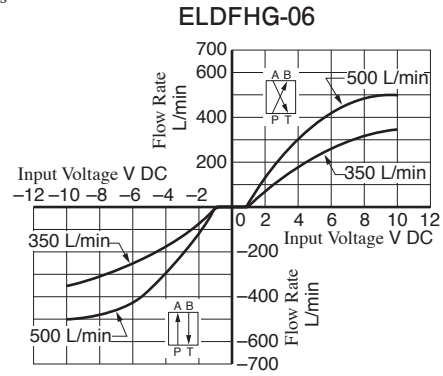
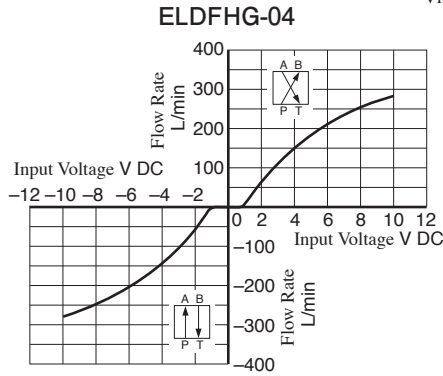

Load Flow Characteristics

Viscosity : 30 mm²/s

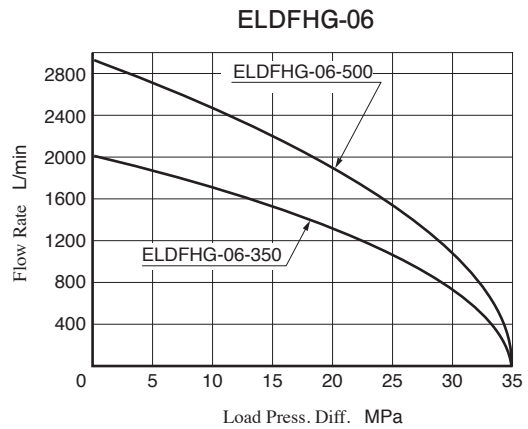
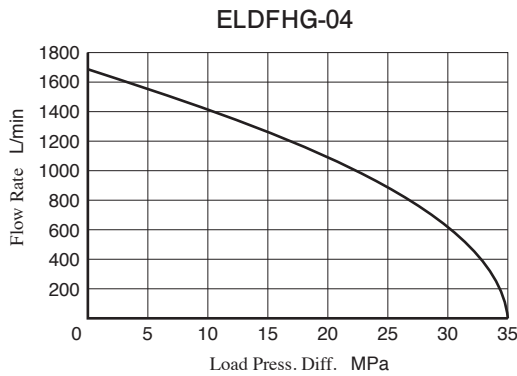

Step Response (Example)

Viscosity : 30 mm²/s

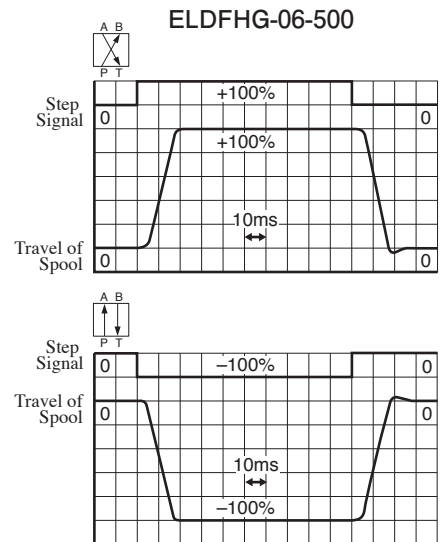
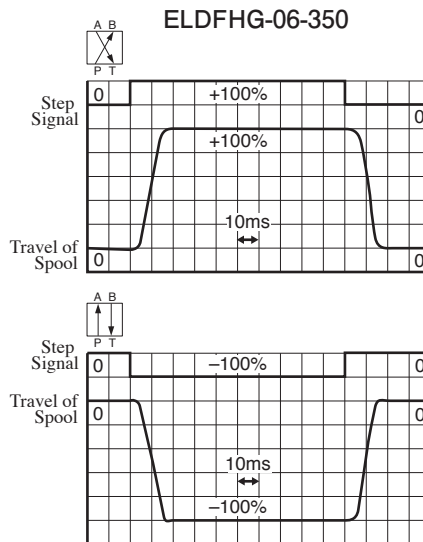
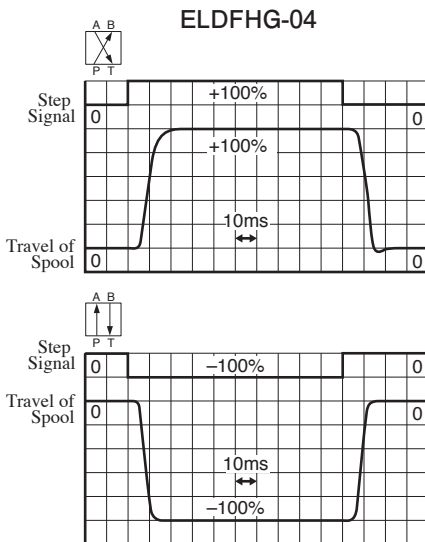

Frequency Response

Input Signal : 0 ± 25 %
Hydraulic Circuit : Port A/B Closed
Supply and Pilot Pressure : 14 PMA
Viscosity : 30 mm²/s

